

# South Carolina Department of Transportation

## REQUEST FOR PROPOSALS **(Final with Addendum 1)**

Interstate 26 Volvo Interchange

Project ID P028843

A Design-Build Project

Berkeley County  
South Carolina

**Final RFP Date: August 12, 2016**

**Addendum 1 Date: September 13, 2016**

# INDEX

**Interstate 26 Volvo Interchange  
Berkeley County, South Carolina**

**A Design-Build Project**

**Project ID P028843**

**INDEX**

**Request for Proposals**

**Attachment A – Agreement**

- Exhibit 1. Cost Proposal Bid Form
- Exhibit 2. Schedule of Values
- Exhibit 3. Scope of Work
- Exhibit 4. Project Design Criteria
  - 4a. Roadway Design Criteria
  - 4b. Structures Design Criteria
  - 4c. Pavement Design Criteria
  - 4d. Traffic Design Criteria
    - Part 1 – Signing and Pavement Markings
    - Part 2 – Work Zone Traffic Control
  - 4e. Hydraulic Design Criteria
  - 4f. Geotechnical Design Criteria
  - 4g. Environmental Design Criteria
- Exhibit 5. Special Provisions and Contract Requirements

**Attachment B – Supplemental Project Design Criteria**

**Attachment C – Project Information Package**

# **REQUEST FOR PROPOSALS**

*South Carolina Department of Transportation*

**REQUEST FOR PROPOSALS**  
**(Final w/ Addendum 1)**

A DESIGN-BUILD PROJECT

Project ID P028843

Interstate 26 Volvo Interchange

Berkeley County, South Carolina

Final RFP Date: August 12, 2016

**Addendum 1 Date: September 13, 2016**

# Table of Contents

<b>1. PURPOSE OF REQUEST FOR PROPOSALS .....</b>	<b>3</b>
<b>2. OVERVIEW .....</b>	<b>3</b>
A. PROJECT DESCRIPTION .....	3
B. PROJECT INFORMATION .....	4
C. SCDOT POINT OF CONTACT .....	4
D. RFP COMMITMENT .....	4
E. NEPA DOCUMENT/PERMIT .....	5
F. INTERCHANGE JUSTIFICATION REPORT .....	5
G. SCHEDULE.....	5
<b>3. GENERAL INSTRUCTIONS .....</b>	<b>5</b>
A. DESIGN-BUILD PROCUREMENT METHOD .....	5
B. RFP FOR INDUSTRY REVIEW .....	6
C. QUESTIONS, CLARIFICATIONS, AND OPEN-FORUM MEETING .....	6
D. FINAL RFP .....	6
E. NON-CONFIDENTIAL QUESTIONS AND ADDITIONAL OPEN-FORUM MEETINGS .....	7
F. CONFIDENTIAL QUESTIONS.....	7
G. PRELIMINARY ALTERNATIVE TECHNICAL CONCEPTS .....	8
H. FORMAL ALTERNATIVE TECHNICAL CONCEPTS.....	10
I. STIPENDS.....	14
<b>4. PROPOSAL DEVELOPMENT AND SUBMITTAL.....</b>	<b>15</b>
A. TECHNICAL PROPOSAL.....	15
B. COST PROPOSAL .....	18
C. PROPOSAL SUBMITTAL .....	18
D. CONFIDENTIALITY OF PROPOSALS .....	19
E. NON-COLLUSION AND EQUAL EMPLOYMENT OPPORTUNITY CERTIFICATION.....	19
<b>5. EVALUATION OF PROPOSALS .....</b>	<b>19</b>
A. PROPOSAL REVIEW COMMITTEE.....	19
B. PROPOSAL REVIEW .....	19
C. TECHNICAL EVALUATION.....	20
D. PRESENTATIONS.....	20
E. CLARIFICATIONS .....	21
F. OPENING OF COST PROPOSALS/BID OPENING MEETING.....	21
G. DISCUSSIONS.....	21
H. BEST AND FINAL OFFER (BAFO) .....	22
I. TOTAL ADJUSTED BID DETERMINATION .....	22
J. PROTEST .....	23
<b>6. SELECTION OF CONTRACTOR.....</b>	<b>24</b>
<b>7. GENERAL INFORMATION .....</b>	<b>25</b>
<b>8. MILESTONE SCHEDULE .....</b>	<b>27</b>
<b>9. COST PROPOSAL BID FORM .....</b>	<b>28</b>
<b>10. NON-COLLUSION CERTIFICATION .....</b>	<b>29</b>
<b>11. EQUAL EMPLOYMENT OPPORTUNITY CERTIFICATION .....</b>	<b>30</b>
<b>12. STIPEND ACKNOWLEDGEMENT FORM .....</b>	<b>31</b>
<b>13. STIPEND AGREEMENT .....</b>	<b>32</b>

# 1. PURPOSE OF REQUEST FOR PROPOSALS

The purpose of this Request for Proposals (RFP) is to select a Proposer to perform the Project services described in this RFP. SCDOT desires that this Project be constructed in a very efficient and timely manner. The proposed Project services are hereinafter referred to as the “Project”. “Proposer,” as used here, includes a firm or firms, consortia, partnerships, joint ventures, and other legal entities, which have been requested by SCDOT to submit a Proposal in response to this RFP. The Proposer shall become the CONTRACTOR if awarded the Contract.

It is not the intention of the SCDOT to receive complete detailed Project analysis and design prior to the selection of a Proposer and the later execution of an agreement. Rather, the response to this RFP shall provide sufficient information to be evaluated by SCDOT to determine if the proposal is in accordance with the specified process and criteria. The Proposal shall be specific enough on assumptions used in its preparation so as to provide the basis for determining a final agreement.

The information obtained under this RFP will become the property of SCDOT without restriction or limitation on its use. With the exception of Alternative Technical Concepts (ATCs), SCDOT shall have unrestricted authority to publish, disclose, distribute, or otherwise use in whole or in part any reports, data, or other materials prepared under this RFP. SCDOT shall retain ownership of all plans, specifications, and related documents.

## 2. OVERVIEW

### A. Project Description

The SCDOT proposes to construct a new interchange on I-26 in Berkeley County that will connect I-26 to Volvo Car Drive on the north side of I-26. The proposed interchange will be located near mile marker 189 approximately two miles from SC 27/Ridgeville Road (Exit 187) and approximately five miles from Jedburg Road (Exit 194).

In addition, the project will include the construction of a portion of Volvo Car Drive and resurfacing and cross slope correction of existing mainline I-26 within the project limits.

SCDOT intends to enter into a contract for services as detailed in the Agreement and Agreement Exhibits.

The Proposer shall be responsible for meeting all Project requirements, specifications, and other applicable criteria as set forth in “Attachments A and B”. Attachment B is located on the SCDOT Design-Build website at <http://www.scdot.org/doing/VolvoInterchange.aspx>. **It is the Proposer’s responsibility to check the website regularly for updates, modifications and additional documentation pertaining to this procurement in Attachment B.**

## **B. Project Information**

Project Information, containing electronic files applicable to the Project, will be posted on the SCDOT Design-Build website. The Project Information Package will include information describing the work performed or obtained by SCDOT prior to entering into the contract for the Project. The Project Information Package is attached to this RFP as “Attachment C”. “Attachment C” may contain additional information not provided at the RFQ stage. Data, reports, plans, electronic files, and any other items supplied in Attachment C which is posted on the SCDOT Design-Build website are for information only. SCDOT shall not be liable for the reliability or accuracy of the information contained therein. **It is the Proposer’s responsibility to check the website regularly for updates, modifications and additional documentation pertaining to this procurement in Attachment C.**

Proposers are encouraged to visit the Project site and to make any additional subsurface explorations or soil tests that Proposer may desire for purposes of preparing the Proposal. The Proposer shall obtain any permits or permissions required prior to any additional subsurface exploration.

## **C. SCDOT Point of Contact**

Ms. Carmen Wright is sole point of contact (POC) and addressee for receiving all communications about the Project with a copy to Ms. Barbara Wessinger, Alternate POC. The Alternate POC has been identified in the event of the unavailability of the POC but is not intended as a substitute for the POC. No contact is allowed with any SCDOT personnel concerning this Project except for questions of an administrative or contractual nature that shall be submitted in writing to the attention of the POC (email is acceptable) with a copy to the Alternate POC. This restriction is in effect until the contract has been awarded. Any Proposer engaging in prohibited communications may be disqualified at the sole discretion of SCDOT. Written inquiries from the Proposer’s POC (as identified in the Proposer’s SOQ) shall be sent to:

Mail Delivery: Carmen Wright (Barbara Wessinger)  
Office of Project Delivery (Office of Chief Counsel)  
South Carolina Department of Transportation  
955 Park Street, Room 101(Room 302)  
Columbia, South Carolina 29202-0191

E-mail: [WrightCL@scdot.org](mailto:WrightCL@scdot.org) ([WessingeBM@scdot.org](mailto:WessingeBM@scdot.org))

## **D. RFP Committal**

The submittal of a Proposal in response to this RFP shall constitute the Proposer’s agreement to enter into a contract with SCDOT for the completion of the Project under the terms set forth in the Agreement and Agreement Exhibits attached hereto as “Attachment A”.

## **E. NEPA Document/Permit**

An Environmental Assessment (EA) and Finding of No Significant Impact (FONSI) were prepared for the Project by the United States Army Corps of Engineers (USACE). In addition, a FONSI was prepared by the Federal Highway Administration



(FHWA). These documents are contained in Attachment B. The Proposer shall be responsible for complying with the NEPA determinations and all environmental commitments.

Permits that have been obtained for the Project are listed in Agreement, Article IX. SCDOT, in coordination with Berkeley County, is seeking a permit modification to accommodate the conceptual design that is posted in Attachment C. Once submitted to USACE, SCDOT will make the permit modification request package available to Proposers.

## **F. Interchange Justification Report**

An Interchange Justification Report (IJR) has been approved by FHWA and is provided in Attachment B.

## **G. Schedule**

Time is of the essence. The Proposer shall enter the Construction Time on the Bid Form. Upon Contract Execution, SCDOT will enter the winning Proposer's Construction Time into the Agreement, Article IV. The Construction Time shall not exceed 750 calendar days.

# **3. GENERAL INSTRUCTIONS**

## **A. Design-Build Procurement Method**

For this Design-Build Project, SCDOT chose the two-phased procurement method. Phase 1, which identified a short-list of qualified Proposers, is complete.

In Phase 2, SCDOT will invite each of the short-listed Proposers to submit their Proposals for completion of the Project. After evaluation of the Proposals, SCDOT plans to award and execute a contract with a single Proposer. Phase 2 includes the following steps:

1. SCDOT releases RFP for Industry Review
2. SCDOT holds Open-Forum Meeting with Proposers to clarify/revise RFP
3. SCDOT releases Final RFP
4. Proposers submit Preliminary Alternative Technical Concepts (ATC) and Confidential Questions
5. SCDOT conducts Confidential One-on-One Meetings with Proposers to discuss Preliminary ATCs and Confidential Questions
6. SCDOT accepts Non-confidential Questions and conducts Open-Forum Meetings with all Proposers, if necessary
7. Proposers submit Formal ATCs and any additional Confidential Questions

8. SCDOT conducts Confidential One-on-One Meetings with Proposers to discuss Formal ATCs and additional Confidential Questions, if necessary
9. SCDOT accepts Non-confidential Questions and conducts Open-Forum Meetings with all Proposers, if necessary
10. SCDOT approves/disapproves ATCs
11. Proposers submit Proposals
12. SCDOT evaluates Proposals
13. SCDOT selects a Contractor

These steps will be carried out following the Milestone Schedule in Section 8. The following paragraphs provide information detailing various steps of the process.

## **B. RFP for Industry Review**

The intent of the RFP for Industry Review is to identify those areas of the RFP that may be in conflict with each other and to point out and clarify mistakes or ambiguities in the RFP.

## **C. Questions, Clarifications, and Open-Forum Meeting**

Once the RFP for Industry Review is issued, the Proposers may submit questions and seek clarification relating to the RFP. An Open-Forum Meeting with all Proposers present will be held on the date provided in the milestone schedule to facilitate this purpose. The purpose of this meeting will be limited to editing the RFP for Industry Review. Non-confidential questions will be accepted via electronic upload to ProjectWise on the dates provided in the Milestone Schedule. Proposers shall submit their questions or comments using the Questions Submittal Form which can be downloaded from the SCDOT Design-Build website under the SCDOT Design-Build Documents and Standard Forms Section.

[http://www.scdot.org/doing/constructionLetting\\_DesignBuild.aspx](http://www.scdot.org/doing/constructionLetting_DesignBuild.aspx).

SCDOT reserves the right to accept or not accept non-confidential questions received after the milestone deadline. SCDOT will review all questions and/or requests for clarification received and, if it deems appropriate, in its sole discretion, may incorporate them in the Final RFP. SCDOT will make every attempt to provide verbal answers during the Open-Forum Meeting to the questions received. SCDOT's verbal answers to Proposers' questions are for general information only, are non-binding, do not constitute legal or other advice, and do not amend or form part of the Final RFP. Nothing discussed at this meeting shall change the requirements of the Final RFP.

## **D. Final RFP**

After completion of the Questions, Clarifications, and Open-Forum Meeting stage, SCDOT may incorporate the Proposers' comments into the RFP, and a Final RFP will be issued. Items that are revised, inserted, or deleted will be highlighted in the Final RFP. In addition to releasing a highlighted version of the Final RFP, SCDOT will also concurrently release a clean version of the Final RFP where all revisions, insertions,

and deletions are not highlighted. It is this clean version of the Final RFP that will be utilized if any future Addendums are required.

## **E. Non-confidential Questions and additional Open-Forum Meetings**

Once the Final RFP is issued, SCDOT will allow Proposers to submit non-confidential questions to request clarification and point out mistakes or ambiguities in the RFP. SCDOT will review all non-confidential questions and/or requests for clarification received and, if it deems appropriate, in its sole discretion, may incorporate them in the RFP through an Addendum.

SCDOT may or may not verbally respond to the non-confidential questions received. If responses are provided, it will be verbally through an Open-Forum Meeting where all Proposers will be invited to attend. This meeting may be conducted via conference call. A Proposers' failure to attend this meeting will not relieve the Proposer of the responsibility for estimating properly the difficulty and cost of successfully performing the work, or for proceeding to successfully perform the work without additional expense to the SCDOT. SCDOT's verbal responses to Proposers' questions are for general information only, are non-binding, do not constitute legal or other advice, and do not amend or form part of the Final RFP. Written responses to any questions will not be provided. Nothing discussed during the Open-Forum Meetings shall change the requirements in the RFP.

Non-confidential questions will be accepted via electronic upload to ProjectWise on the dates provided in the milestone schedule. Written questions submitted outside of these dates may not be accepted. If deemed necessary by the SCDOT, Open-Forum Meetings will be held within 10 business days following receipt of non-confidential questions. Proposers must use the Question Submittal Form that is provided on the SCDOT Design-Build website under the SCDOT Design-Build Documents and Standard Forms Section.

[http://www.scdot.org/doing/constructionLetting\\_DesignBuild.aspx](http://www.scdot.org/doing/constructionLetting_DesignBuild.aspx).

## **F. Confidential Questions**

Once the Final RFP is issued, SCDOT will allow Proposers to submit confidential questions to provide the Proposer an opportunity to confidentially discuss the contents of his/her proposal with SCDOT personnel. SCDOT will determine/confirm if questions submitted are considered confidential, as identified by the Contractor on the Question Submittal Form. If more than one confidential question on the same topic has been received from multiple Proposers, SCDOT has the right to revise the RFP to include that concept as an addendum to the RFP. If submitted confidential questions are determined to be of non-confidential nature or identify an error or omission in the RFP, the SCDOT, if it deems appropriate, in its sole discretion, may incorporate them in the RFP through an Addendum.

SCDOT may or may not verbally respond to the submitted confidential questions during the Confidential Preliminary ATC Meeting and/or any Confidential One-on-One Formal ATC Meetings. SCDOT's verbal responses to Proposers' questions are

for general information only, are non-binding, do not constitute legal or other advice, and do not amend or form part of the Final RFP. Written responses to any questions will not be provided. Nothing discussed during the Confidential Preliminary ATC Meeting and/or any Confidential One-on-One Formal ATC Meetings shall change the requirements in the RFP.

Confidential questions will be accepted via electronic upload to ProjectWise on the dates identified in the Milestone Schedule for submittal of Preliminary and Formal ATCs. Written questions submitted outside of these dates may not be accepted.

Confidential questions received on the dates prior to the Confidential Preliminary ATC Meetings with Proposers may be discussed at that meeting. For confidential questions received on the allowable date(s) after the Confidential Preliminary ATC Meeting, verbal answers may be answered with a Confidential One-on-One Questions Meeting/conference call which may be held within 10 business days following receipt of the confidential questions. Proposers must use the Question Submittal Form that is provided on the SCDOT Design-Build website under the SCDOT Design-Build Documents and Standard Forms Section.

[http://www.scdot.org/doing/constructionLetting\\_DesignBuild.aspx](http://www.scdot.org/doing/constructionLetting_DesignBuild.aspx).

## **G. Preliminary Alternative Technical Concepts**

An ATC is a confidential request by a Proposer to modify a contract requirement, specifically for that Proposer, prior to the Proposal due date. Requests for contract modifications that may qualify as ATC's may include but not be limited to changes in design criteria, changes in alignments or location of facilities, changes to review and submittal processes, change in material or structure types, change in interchange type, etc. The ATC process provides an opportunity for design-build proposals to promote innovation, find the best solutions, and to maintain flexibility in the procurement process. ATCs are evaluated for approval or disapproval by SCDOT within the deadline set forth in the Milestone Schedule. In order to be approved, an ATC must be deemed, in SCDOT's sole discretion, to provide a Project that is equal or better in quality or effect on an overall basis than the Project would be without the proposed ATC. Concepts that simply delete scope, lower performance requirements, lower standards, conflict with environmental commitments, or reduce contract requirements are not acceptable as ATCs. SCDOT reserves the right, in its sole discretion, to reject any ATC. No ATC shall be included in the proposal unless approved by SCDOT in writing prior to the proposal submission deadline.

For this project, if an alternate type of interchange that differs from the conceptual design in Attachment C is proposed, an ATC must be prepared and submitted for review and approval.

### **1. Submittal of Preliminary ATCs**

Preliminary concepts are intended to be an informal inquiry by the Proposer to explore a concept and a quick method by SCDOT to review and comment on potential development of ATCs prior to investment of time and resources by the Proposer. Preliminary concepts shall present a Description, Deviations, and a

range of Costs, as further described in Section 3G.1. Other items identified in Section 3.G.1 can be provided, but are not required. The amount of information provided shall be constrained to the boxes provided in the Preliminary ATC Submittal Form. SCDOT will allow one single letter sized attachment (8.5” x 11”) for detailed drawings or sketches. Submission of preliminary concepts does not change or extend the submission deadline of Formal ATCs.

Proposers shall be limited to two packages of preliminary concepts and the total number of preliminary concepts shall not exceed twenty. A package is a submittal of up to ten ATCs. If more than one preliminary concept on the same topic has been received from multiple Proposers, SCDOT has the right to revise the RFP to include that concept as an addendum to the RFP.

All preliminary ATCs shall be submitted electronically by uploading to ProjectWise in a single zip folder with each file name using the following format: PATCSummary\_ProposerName or PATCNumber\_ProposerName. The Proposers shall use the ATC Summary Form and the Preliminary ATC Submittal Form, which can be downloaded from the SCDOT Design-Build website under the SCDOT Design-Build Documents and Standard Forms Section.

[http://www.scdot.org/doing/constructionLetting\\_DesignBuild.aspx](http://www.scdot.org/doing/constructionLetting_DesignBuild.aspx).

The Proposer shall submit Preliminary ATCs for review in accordance with the Milestone Schedule. All Preliminary ATC information being exchanged between Proposers and SCDOT shall occur only on the specific dates shown, unless otherwise directed by the SCDOT POC.

## **2. Confidential Preliminary ATC Meeting**

SCDOT will offer Confidential Preliminary ATC Meetings at the request of the Proposers. Proposers shall request a meeting in writing (email is acceptable) addressed to the SCDOT POC with a copy to the alternate POC by the date specified in the Milestones Schedule. SCDOT will reserve two hours of meeting time for each Proposer that requests a meeting, and SCDOT will give time of day preference in the order that requests are received. The purpose of this meeting is to provide the Proposer with the opportunity to confidentially discuss the preliminary ATCs and questions with SCDOT personnel. SCDOT may answer questions at the meeting verbally. Verbal responses are for information only and are not binding. Nothing discussed at this meeting shall change the requirements in the RFP.

## **3. Responses to Preliminary ATCs**

SCDOT will provide a response to the Proposer no later than seven business days after the Confidential Preliminary ATC Meeting. SCDOT responses will be “Favorable,” “Not Favorable,” “Addendum,” or “Not an ATC.” If additional clarification is needed after the Preliminary ATC Meeting, Proposers are responsible for sending the clarification as soon as possible so that SCDOT has an opportunity to assess the benefits of the concepts before providing a response in accordance with the Milestone Schedule. A favorable response by SCDOT in no

way guarantees that the concept will become an approved formal ATC. The favorable response may be subject to conditions.

## H. Formal Alternative Technical Concepts

### 1. Submittal of Formal ATCs

Each formal ATC submittal shall include the following.

- **Description:** A detailed description and schematic drawings of the configuration of the ATC or other appropriate descriptive information (including, if appropriate, specifications, construction tolerances, special provisions, proposed bridge types, product details, and a traffic operational analysis)
- **Usage:** Locations where and an explanation of how the ATC would be used on the Project
- **Deviations:** List in table format, all references to any requirements of the RFP or to any requirements of the Contract Documents that are inconsistent with the proposed ATC. Include an explanation of the nature of the proposed deviation and a request for approval of such deviations or a determination that the ATC is consistent with the requirements of the RFP
- **Justification:** Justify use of the ATC and why the deviations from the requirements of the RFP should be allowed
- **Schedule:** Proposed changes to the Project schedule if applicable
- **Impacts:** Identify potential impacts on vehicular traffic, safety, community, utilities, right of way, and the environment
- **History:** A detailed description of other projects where the ATC has been used under comparable circumstances, the success of such usage, and names and telephone numbers of project owners that can confirm such statements
- **Risks:** A description of added risks to SCDOT and other persons associated with implementing the ATC
- **Costs:** An estimate of the impact of the ATC on the Proposal Price and the ATC implementation costs to SCDOT, FHWA, CONTRACTOR, or other person during construction, maintenance and operations
- **Quality:** A description of how the ATC is equal or better in quality and performance than the requirements of the RFP
- **Operations & Maintenance:** Any changes in operation or maintenance requirements associated with the ATC.

The technical response to each item outlined above shall be provided in the Formal ATC Submittal Form. Text submissions shall be limited to the form and shall not be provided as attachments. Only drawing details, plan sheets, charts, tables, graphs, and supporting reports/analyses can be provided as an attachment to the Formal ATC Submittal Form.

**A maximum number of ten formal ATCs may be submitted to SCDOT by the Proposer for consideration.**

All formal ATCs shall be submitted electronically by uploading to ProjectWise in a single zip folder with each file name using the following format: FATCSummary\_ProposerName or FATCNumber\_ProposerName. The Proposers shall use the ATC Summary Form and the Formal ATC Submittal Form, which can be downloaded from the SCDOT Design-Build website under the SCDOT Design-Build Documents and Standard Forms Section.

[http://www.scdot.org/doing/constructionLetting\\_DesignBuild.aspx](http://www.scdot.org/doing/constructionLetting_DesignBuild.aspx).

The Proposer shall submit formal ATCs for in accordance with the Formal ATC Milestone schedule below. All information being exchanged between Proposers and SCDOT shall occur only on the specific dates shown, unless otherwise directed by the SCDOT POC.

<b>Formal ATC Milestone Schedule</b>		<b>Date</b>
<b>1st Round of Formal ATCs</b>	Proposer submits Formal ATCs for Initial Review	Wednesday, September 21, 2016 by 2:00pm EST
	SCDOT responds with final determination, asks questions/requests information, or provides conditional response	Wednesday, September 28, 2016
	Proposer re-submits Formal ATC in its final form (no revisions allowed after this submittal, unless requested by SCDOT)	Wednesday, October 5, 2016 by 2:00pm EST
	SCDOT provides final determination for 1st Round of Formal ATCs	Wednesday, October 12, 2016
<b>2nd Round of Formal ATCs</b>	Proposer submits Formal ATCs for Initial Review	Wednesday, October 5, 2016 by 2:00pm EST
	SCDOT responds with final determination, asks questions/requests information, or provides conditional response	Wednesday, October 12, 2016
	Proposer re-submits Formal ATC in its final form (no revisions allowed after this submittal, unless requested by SCDOT)	Wednesday, October 19, 2016 by 2:00pm EST
	SCDOT provides final determination for 2nd Round of Formal ATCs	Wednesday, October 26, 2016

## **2. Review of Formal ATCs**

Review of formal ATCs shall be in accordance with the information and Formal ATC Milestone Schedule provided above.

- a. **Initial Review:** Upon completion of the initial review, SCDOT will either make a final determination in accordance with Section 3G.3, request more information, or provide a conditional response.
- b. **More Information Needed:** SCDOT may submit written questions to the Proposer and/or request a one-on-one meeting in order to better understand the details of the formal ATC.
  - 1) **Questions:** In accordance with the ATC Milestone Schedule, SCDOT may submit written questions to the Proposer after the receipt of a formal ATC. Proposers will then have the opportunity to resubmit according to the Formal ATC Milestone Schedule.
- c. **One-on-One Meetings:** Confidential One-on-One Formal ATC meeting(s) may be scheduled to fully understand the details of any formal ATCs. These meetings will be restricted to those persons involved in the review of the formal ATC and limited to discussions of the Proposer's formal ATC approach and any outstanding confidential questions. The purpose of this meeting is to discuss proposed changes, answer questions, and other relevant issues. Verbal responses are for information only and are not binding. Nothing stated at any formal ATC meeting(s) will modify the RFP or contract documents. SCDOT reserves the right to disclose to all Proposers any issues raised during the ATC meeting(s) in an addendum. However, SCDOT will not disclose any information pertaining to an individual Proposer's ATCs or other technical concepts to other Proposers.
- d. **Conditional Response by SCDOT:** If the SCDOT states a formal ATC is not approved in its present form, it may be reconsidered for approval upon satisfaction, in SCDOT's sole discretion, of certain identified conditions that must be met or certain clarifications or modifications that must be made by Proposer. The Proposer shall not have the right to incorporate this formal ATC into the Proposal unless and until the formal ATC has been resubmitted in accordance with the Formal ATC Milestone Schedule, with the conditions, clarification and modifications satisfied, and SCDOT has made a final determination.
- e. **No Response from SCDOT:** If the Proposer does not receive correspondence from SCDOT in accordance with the Formal ATC Milestone Schedule, the formal ATC is deemed rejected by SCDOT, unless written notification to extend this period is given by SCDOT.

### 3. Final Determination of SCDOT

SCDOT will make one of the following written determinations with respect to each properly submitted ATC:

- a. The ATC is approved.
- b. The ATC is not approved.
- c. The submittal does not qualify as an ATC but appears eligible to be included in the Proposal without an ATC (i.e., the concept appears to conform to the RFP and to be consistent with other contract requirements).



- d. The ATC is deemed to take advantage of an error or omission in the RFP, or other documents incorporated into the contract by reference, the ATC will not be considered, and the RFP will be revised to correct the error or omission.
- e. More than one formal ATC has been received on the same topic and SCDOT has elected to exercise its right to issue an addendum to the RFP to include that topic.

Once an ATC has been approved, only the entire ATC is eligible for inclusion into the Proposal. The inclusion of partial ATCs into a Proposal is not allowed, unless the individual ATCs have received separate approval by SCDOT.

Each Proposer, by submittal of its Proposal, acknowledges that the opportunity to submit ATCs was offered to all Proposers, and waives any right to object to SCDOT's determinations regarding acceptability of ATCs.

#### **4. Incorporation into Proposal**

A Proposer has the option to include any or all approved ATCs in its Proposal. If SCDOT responded to an ATC by identifying conditions for approval, Proposer may not incorporate such ATC into the Proposal unless all conditions have been met. Copies of SCDOT's ATC approval letters, which shall include the ATC Summary Form, for each incorporated ATC shall be included in the Technical Proposal appendices. Proposals with or without ATCs will be evaluated against the same technical evaluation factors set forth in the Evaluation of Proposals section, and the inclusion of an ATC, including an ATC that provides technical enhancements, may or may not receive a higher technical rating. SCDOT approval of an ATC shall not be considered a guaranty that the proposal incorporating the ATC will be selected. SCDOT's rejection of an ATC will not entitle the Proposer to an extension of the Proposal submission deadline on the Milestone Schedule or claim for additional costs or delays, including development costs, loss of anticipated profits, or increased material or labor costs.

The Total Cost to Complete shown in the Cost Proposal shall reflect any incorporated approved ATCs.

Except for incorporating approved ATCs, the Proposal may not otherwise contain exceptions to or deviations from the requirements of the RFP.

#### **5. Value Engineering**

An approved ATC that is not incorporated into the proposal will not be considered a pre-approved value engineering change.

#### **6. Abandonment of ATC by Proposer**

If the approved ATC is abandoned by the Proposer, is unable to obtain required approvals, is otherwise proved to be infeasible, or fails to be constructed for any reason, the successful Proposer is obligated and required to complete the Project utilizing the original RFP requirements at the awarded cost, and shall be responsible for any redesign costs.

## 7. SCDOT's use of Concepts Contained in an ATC

SCDOT expressly reserves the right to adopt and use any ATC, approved or disapproved, by the successful Proposer on this contract or other contracts administered by SCDOT. By submitting a Proposal, all unsuccessful Proposers acknowledge that upon acceptance of the designated stipend, all approved or disapproved ATCs may be included in this contract or other contracts administered by SCDOT and shall become the property of SCDOT without restriction on use. Prior to contract execution, limited negotiations may be conducted as necessary to incorporate the ideas and concepts from unsuccessful Proposers, provided a stipend is accepted by the unsuccessful Proposer.

## 8. Proposer Obligations

The successful Proposer, in addition to performing all other requirements of the Contract Documents, shall:

- a. Obtain and pay the cost of obtaining all required approvals including approvals required to implement any approved ATC(s) incorporated into the Contract Documents;
- b. Obtain and pay the cost of obtaining any third party approvals required to implement any approved ATC(s) incorporated into the Contract Documents; and
- c. Unless otherwise noted in the Contract, be responsible for all costs and/or delays of any nature associated with the implementation of any approved ATC incorporated into the Contract Documents.
- d. Be solely responsible for reviewing the RFP and determining if the ATC deviates from the revised requirements if SCDOT revises the RFP after a formal ATC has been approved. The Proposer must submit a request for approval of all additional variances required within five (5) business days of receipt of the revised RFP.

## I. Stipends

By submitting a Proposal in response to the RFP, the Proposer acknowledges the following:

1. It is the intent of SCDOT to award a stipend of **\$70,000** to each responsible and responsive Proposer subject to the terms of the Stipend Agreement set forth in Section 13 of the RFP.
2. If Proposer elects to receive a stipend, the Stipend Acknowledgement form and Stipend Agreement shall be signed by Proposer and submitted as part of the unsealed Technical proposal. The Stipend Agreement will not count against the specified page limit.

## 4. PROPOSAL DEVELOPMENT AND SUBMITTAL

Proposals must be submitted separately in two parts, a Technical Proposal and a Cost Proposal. Required forms, conceptual plans, and approved ATCs used in preparing the Proposer's Cost Proposal shall also be incorporated in the Technical Proposal as Appendices. If a Proposer does not, at a minimum, submit responses to these items, the submittal may be considered non-responsive and returned without further review/evaluation. Any concepts that conflict with the RFP specifications discovered during the evaluations or after award of the Project, and which are not approved as an ATC, shall not prevail over RFP specifications.

### A. Technical Proposal

The Technical Proposal Narrative shall contain no more than ten pages, excluding any plans, signed forms, and appendices. Any Conceptual Plans developed by the Proposer to accompany the Proposer's Narrative shall be incorporated in the Technical Proposal as Appendices.

The Technical Proposal Narrative shall be on single sided 8.5"x11" letter sized paper, with minimum twelve-point Times New Roman font and double line spacing for text. Any Conceptual Plans shall be provided in black and white on single sided 11"x17" paper unless otherwise noted herein.

The Technical Proposal Appendices shall include Conceptual and MOT Plans, MOT narrative/discussion, required forms, and approved ATCs being incorporated into the Proposer's Cost Proposal. If RFP addenda are issued, the Technical Proposal Appendices shall include the Notices of Receipt of Addenda.

In addition to submittal of required appendices documents, to be responsive, at a minimum, the Technical Proposal shall include a narrative describing the Project Delivery and Approach.

**In the Technical Proposal Narrative**, Proposers shall respond to the following items and shall develop the narrative in the following sequence:

1. **Describe the Project Delivery & Approach by discussing/providing the following. (25 points)**
  - a. Identify the proposed schedule for implementing the Project. Include the sequence of construction and material and equipment staging plan. Describe methods that will allow a reduction in the overall construction scheduled on the project. The Cost Proposal includes Construction Time so the narrative may not include the actual proposed time. The Proposer may use generalities to reference the proposed time.
  - b. Describe the proposed design submittal process and sequencing and the proposed plan that will allow SCDOT to conduct efficient and complete reviews. Include discussion of how the design review process is related to the proposed project phasing/segmentation.

- c. Describe the proposed approach for coordination with adjacent projects and contractors working in the area.

**2. Innovation and Quality (5 Points)**

- a. Describe the innovation and additional quality shown in the project delivery and approach, conceptual roadway plans, conceptual bridge plans, and maintenance of traffic.
- b. Identify materials, designs, and construction methods that would minimize maintenance costs in the future to the SCDOT or benefit the Project.

**In the Technical Proposal Appendices**, Proposers shall provide the following items.

**3. Provide Conceptual Roadway Plans (35 points).** The intent of conceptual roadway plans is for the proposer to clearly demonstrate their understanding of requirements of the RFP and the Team's approach to meet those requirements. The quality of the plans will be reviewed and scored for design content and compliance with RFP requirements, including ATC's, if any, rather than plan development/preparation conformance. The following shall be provided.

- a. Typical sections for all roadways including functional classification and design speeds.
- b. Plan and profile for the entire project limits including interchange layout.

Plan view shall include:

- Geometric layout with reference data
- Taper lengths
- Deceleration/acceleration lengths
- Construction limits
- Control of Access Limits (mainline and interchange)
- Proposed Right of Way
- Clear zone limits
- Roadside barriers (location and type)
- Bridge and box culverts
- Limits of retaining walls (plan view)
- Significant drainage features

Profile view shall indicate.

- Grades
- Vertical curvature (length & K value)

- c. Cross sections only where necessary to indicate a significant difference from the conceptual plans in Attachment C. These should be limited to only those showing a significant change and may be segmented for only the areas where changes occur.
- d. Special emphasis details (where needed to clearly demonstrate understanding and approach - isolated locations such as ramp ties, wall types, etc.)

**4. Demonstrate an understanding of Maintenance of Traffic (MOT) for the project by providing the following as part of the appendix (10 points):**

- a. A MOT Narrative that includes any stage durations, I-26 lane closures, and traffic control plan for placing girders over the interstate. The MOT Narrative can be supplemented by plans or drawings and typical sections (11"x17" sheets or roll plots) as necessary to clearly demonstrate the Maintenance of Traffic for the project. MOT plans, drawings, and typical sections may be color or black and white. The narrative should describe the team's approach to minimization of traffic shifts, lane closures, and construction stages.
- b. Discuss permanent and temporary provisions for reversals of the interstate lanes in the event of a hurricane.
- c. Describe any commitments to early completion of work items to improve maintenance of traffic and traffic flow including the interstate mainline and the interchange ramps.
- d. Describe the team's plan for public involvement and notification of traffic impacts.

**5. Provide Conceptual Bridge Plans for the overpass bridges which shall consist of the following (30 points).**

- a. Plan and profile of bridge showing horizontal and vertical clearances and expansion joint locations and types of joint materials.
- b. Superstructure cross sections and substructure elevations showing pertinent structural elements, dimensions, and types of bearings.
- c. Construction staging plan for bridge work including dimensions of temporary roadway widths both on the bridges and, where applicable, on the roadway beneath the bridges.
- d. Bridge construction access plan showing areas used to access the bridge work and showing proposed equipment and material handling locations and staging.
- e. Retaining wall envelopes at the bridge ends showing top of wall, ground lines, and bottom of wall (required only if retaining walls are proposed).

**6. Required Forms**

Required forms to be included in the Technical Proposal appendix include:

- a. Stipend Acknowledgement form
- b. Stipend Agreement
- c. EEO Certificate
- d. Non-Collusion Certificate
- e. Addendum receipt
- f. Notification receipt of changes to Attachment B
- g. Updated Organization Chart and Affidavit of availability of Key Individuals
  - Provide an updated organizational chart from that provided in the Proposers Statement of Qualifications. If Key Individuals are no longer available, Proposers shall notify the SCDOT immediately in accordance with the RFQ. Prior to submittal of the technical proposal,

Proposers shall follow the change process as described section 8 of the RFQ.

- The Proposer shall include an affidavit stating that the key individuals shall be available at the times and durations required in the RFQ. If the Organizational Chart is revised from the Proposer's SOQ, the Proposer shall include the SCDOT approval in this appendix.

#### h. Prequalification Requirements

- For all construction firms that are part of the design build team, provide SCDOT Prequalification Certificates for the work they are identified to perform. If the Proposer is a Joint Venture, or other entity organized specifically for this Project, qualification documentation must be submitted for each member.

**The Technical Proposal Narrative and Conceptual Plans submitted as a part of the Technical Proposal will be considered a commitment and shall become part of the contract. Inconsistent and/or non-conforming narrative or conceptual plans do not relieve the Proposer of meeting the requirements set forth in the Final RFP.**

## B. Cost Proposal

The Cost Proposal shall be clearly marked as "Confidential Proprietary Information" by the Proposer and shall include the completed Cost Proposal Bid Form provided at the end of this document. The Cost Proposal Bid Form shall be sealed in a separate envelope and delivered as part of the Cost Proposal per the Milestone Schedule.

## C. Proposal Submittal

Proposals must be submitted separately in two parts, a Technical Proposal and a Cost Proposal. Proposers are required to upload the Technical Proposal, signed forms, and appendices, online through ProjectWise in PDF format. Only one completed submittal per team will be accepted and shall be uploaded by either the lead contracting entity or lead design firm. Please be advised of the time required to set up new account. All requests for new accounts must be received 72 hours prior to the proposal deadline indicated in the Milestone Schedule. More information is available at [http://www.scdot.org/doing/constructionletting\\_projectwise.aspx](http://www.scdot.org/doing/constructionletting_projectwise.aspx).

Proposers are to physically deliver and submit three printed and bound hard copies of the Technical Proposal, signed forms, and appendices. Proposers are to physically deliver one sealed, printed copy of the Cost Proposal. Please deliver to:

Carmen Wright  
Office of Project Delivery  
South Carolina Department of Transportation  
955 Park Street, Room 101  
Columbia, South Carolina 29202-0191

Proposers are responsible for affecting delivery by the date in the Milestone Schedule. Late submissions will be rejected without opening. SCDOT accepts no responsibility for misdirected or lost proposals.

#### **D. Confidentiality of Proposals**

Proposer shall specifically mark as “CONFIDENTIAL” any elements of their submission that they consider to contain confidential or proprietary information and the release of which would constitute an unreasonable invasion of privacy. All markings must be conspicuous; use color, bold, underlining, or some other method in order to conspicuously distinguish the mark from the other text. Do not mark the entire proposal as confidential or proprietary. **In the Technical Proposal appendix, Proposer shall include a list of page numbers that contain confidential and/or proprietary information. Failure to include this list in the Technical Proposal appendix waives the confidentiality protection and subjects the information to disclosure in accordance with the law.** In determining whether to release documents, the SCDOT will rely on the Proposer’s list of page numbers and the Proposer’s marking of each page or portions of pages of documents, as required by these instructions, as being either “Confidential” or “Trade Secret”. Proposer shall be prepared upon request to provide justification of why such materials shall not be disclosed under the South Carolina Freedom of Information Act, Section 30-4-10, et seq., South Carolina Code of Laws (1976) as amended. Proposals will be kept confidential and will not be disclosed, except as may be required by law.

#### **E. Non-collusion and Equal Employment Opportunity Certification**

Proposers shall certify that they have not participated in any collusion or otherwise taken any action in restraint of free competitive bidding in connection with the submission of this proposal on this Project. A proposal submitted without the non-collusion certification may be deemed non-responsive. The non-collusion certification form provided as part of this document shall be submitted as part of the Technical Proposal and will not count against the specified page limit. Each joint venture team member shall submit a separate non-collusion certification.

Proposers shall complete the Equal Employment Opportunity (EEO) Performance Certification form provided as part of this document. A proposal submitted without the EEO certification may be deemed non-responsive. The EEO certification form shall be submitted as part of the Technical Proposal and will not count against the specified page limit. Each joint venture team member shall submit a separate EEO certification.

## **5. EVALUATION OF PROPOSALS**

#### **A. Proposal Review Committee**

A Proposal Review Committee (“Committee”) will be appointed by SCDOT to review the Proposals. The committee members will be comprised of SCDOT employees. In addition, SCDOT will assemble a group of resource members having expertise in the various disciplines required by the Project including the FHWA.

## B. Proposal Review

The Committee will review the Proposals and determine whether each Proposal is responsive based on the Proposal Development criteria in Section 4, Paragraph A and B. Responsive Proposals will be accepted by the Committee for advancement to the Bid Opening. Proposers that submit a non-responsive proposal will be sent a letter with a detailed explanation as to the reasons for determining non-responsiveness. Any nonresponsive unopened Cost Proposal(s) will be retained by SCDOT until either contract execution or RFP cancelation and then returned to the nonresponsive Proposer(s). All original copies of the nonresponsive Technical Proposal(s) will be retained by SCDOT. Reasons for determining a proposal to be non-responsive may result from, but are not limited to, the following: failure to provide all information requested in the proposal, failure to conform to the material requirements of the RFP, conflict of interests, conditional proposals, failure to provide complete and honest information, failure to complete the Cost Proposal Bid Form correctly, or failure to submit the EEO certification. Proposals which impose conditions that modify material requirements of the RFP may be rejected as non-responsive. Proposers will not be given an opportunity to correct any material nonconformity. Any deficiency resulting from a minor informality may be clarified or waived at the sole discretion of the SCDOT.

## C. Technical Evaluation

All Technical Proposals will be evaluated for technical merit and scored on a scale of 0 to 105 points prior to opening the Cost Proposals. The Committee will determine responsiveness of the Technical Proposal based on responses to all items requested in the RFP and conformance with the requirements of RFP Attachments A and B. Technical Proposals that meet the requirements of the RFP will be scored at 100.0. Scores will be adjusted for Technical Proposal based on quality and innovation. A Proposer will be deemed non-responsive if the evaluation of their Technical Proposal results in a score less than 95.0. A maximum of 5.0 points, resulting in a maximum score of 105.0, are available for those Technical Proposals that promote innovation. The following criteria will be used in determining the Technical Score.

Project Delivery and Approach	25.0 points
Conceptual Roadway Plans	35.0 points
Understanding of MOT	10.0 points
Conceptual Bridge Plans	30.0 points
Innovation	5.0 points
Required Forms	<u>Pass/Fail</u>
<b>Total Available</b>	<b>105.0 points</b>

Each member of the Committee will examine each proposal in detail to measure its contents against the evaluation factors and assign a score to each factor. The Committee will then meet and formulate its collective conclusions. The Committee must discuss significant variations in evaluator's scores or assessments of technical merit and resolve discrepancies or fully explain them. The Committee will assign the final score for each Technical Proposal by consensus.



## **D. Presentations**

Proposers who have submitted responsive Technical Proposals may be invited by the Committee to make a presentation. The presentation, if required, will allow the Proposers an opportunity to further explain any aspect of their Technical Proposals. The Committee may address questions to the Proposer after the presentation.

## **E. Clarifications**

SCDOT, at its sole discretion, shall have the right to seek clarifications from any Proposer to fully understand information contained in their responses to the RFP. Clarifications mean a written or oral exchange of information which takes place after the receipt of proposals when award without discussions is contemplated. The purpose of clarifications is to address minor or clerical revisions in a proposal.

## **F. Opening of Cost Proposals/Bid Opening Meeting**

All Technical Proposals will be evaluated for responsiveness based on those items requested in this RFP. Those Technical Proposals deemed non-responsive will be handled according to Section 5, Paragraph B. As detailed above, those Technical Proposals deemed responsive [proposals with a technical score of 95.0 or higher] will advance to the Bid Opening.

The Technical Score will be provided confidentially in a sealed envelope to each Proposer at the Opening of Cost Proposals/Bid Opening meeting as shown on the Milestones Schedule in Section 8 of this RFP. After distribution of the Technical Scores, the Cost Proposals of Proposers with responsive Technical Proposals will be opened. After opening, SCDOT shall adjourn the meeting to analyze the bids.

The Total Bid amount shown on the Cost Proposal Bid Form and the Technical Score for each respective Proposer will be entered into a spreadsheet and analyzed. The Total Bid will be evaluated in accordance with SCDOT's Bid Review Policies and Procedures. Each Total Bid will be compared against the confidential SCDOT Engineer's Estimate.

If upon analysis, one or more of the Total Bids is within an acceptable range of the Engineer's Estimate, all Total Bids will be adjusted to determine the lowest Total Adjusted Bid.

If upon analysis, all of the Total Bids exceed an acceptable range of the Engineer's Estimate, SCDOT personnel may then assess if either award outside the prescribed range is justified, or if the SCDOT will hold discussions in accordance with Section 5.G and request a Best and Final Offer (BAFO) from all responsive Proposers.

SCDOT intends to award the contract to the Proposer with the lowest Total Adjusted Bid. However, the RFP may be cancelled after opening, but prior to the issuance of an award, when such action is determined in writing to clearly be in the best interest of the State. If the RFP is cancelled, Cost Proposals may be returned to the Proposers and a new solicitation may be conducted for the Project.

## **G. Discussions**

If necessary, after the bid opening meeting, SCDOT may hold confidential discussions with each responsive proposer relating to aspects of their respective proposal. The discussion process is intended to assure that Proposers fully understand the requirements of the RFP and that the evaluation team fully understands each qualified proposer's technical proposal and the proposer's ability to perform as needed. Discussions involve only a limited exchange of information. Discussions are not negotiations. If SCDOT determines that discussions are necessary, SCDOT will forward a written invitation to the responsive proposers.

SCDOT reserves the right to hold multiple discussions at any length of time with any or all of Proposers. All discussions shall be controlled by the SCDOT POC. Proposers shall not communicate with any other SCDOT employees regarding these discussions except at the appropriate discussion meetings.

At the conclusion of discussions, SCDOT may either (1) proceed with award the contract to the selected Proposer based on the lowest Total Adjusted Bid at the bid opening meeting; (2) issue a Request for Best and Final Offers (BAFO); or (3) cancel the procurement.

## **H. Best and Final Offer (BAFO)**

At the conclusion of discussions, if SCDOT determines that proposal revisions are warranted, SCDOT may issue a Request for Best and Final Offer (BAFO). If necessary, SCDOT may also revise the RFP to provide clarifications related to the Request for BAFO. The Request for BAFO will include instructions for preparing and submitting the BAFO and will include a new Milestone Schedule. If only Cost Proposal revisions are warranted, Proposers will revise and resubmit, and SCDOT will hold a second Bid Opening Meeting. If Technical Proposal revisions are warranted, Proposers will revise and resubmit, and the procurement process will return to Section 5, Paragraph B.

Only one Request for BAFO can be issued for this RFP. If upon analysis of the BAFO's, all of the bids exceed an acceptable range of the Engineer's Estimate, SCDOT will adjourn the BAFO bid opening meeting. SCDOT personnel may then assess if either award outside the prescribed range is justified or if the RFP will be cancelled.

The discussion and BAFO process do not alter or amend the RFP requirement that Proposers agree to hold their proposal offers available for acceptance a minimum of ninety calendar days after the Bid Opening Meeting.

## **I. Total Adjusted Bid Determination**

Award of the Contract, if made, will be made to the responsible and qualified Proposer who submits the lowest Total Adjusted Bid. To determine the Total Adjusted Bid, the sum of each Proposer's Total Cost to Complete will be divided by their Technical Score and then the Project Construction Time Cost will be added. In the event that two or more Proposers are determined to have the same lowest Total Adjusted Bid, the

award, if made, will be made to the Proposer with the highest Technical Score. The following formula will be used to evaluate the values given on the Cost Proposal Bid Form:

$$\text{Total Adjusted Bid} = (A/\text{Technical Score}) + B:$$

- A Total Cost to Complete all work to be performed under the contract
- B Project Construction Time Cost (B = b x dc)
- b Construction time (b) is defined as calendar days **from Notice to Proceed** to Substantial Work Completion of the Project.
- dc Daily cost associated with the Project as stipulated on the Cost Proposal Bid Form (\$10,000 per day)

Technical Score is assigned a value from 0 to 105.0 based on the proposal’s technical merit; expressed as a decimal – i.e., a technical score of 98.2 would be expressed as 0.982

**Example for Determining Total Adjusted Bid**

Proposal	Total Cost to Complete (A)	Construction Time (b)	Construction Time Cost (B)	Technical Score	Total Adjusted Bid
A	\$30,000,000	750	\$7,500,000	0.95	\$39,078,947.37
B	\$35,000,000	720	\$7,200,000	0.90	N/A
C	\$38,000,000	690	\$6,900,000	1.00	\$44,900,000.00
D	\$31,000,000	750	\$7,500,000	1.05	\$37,023,809.52

Note: In this example, Proposal B was determined to be non-responsive and Proposal D was determined to be the lowest Total Adjusted Bid.

**J. Protest**

**1. Grounds for Protest**

- a. Protest of contents of solicitation (Invitation For Bids or Requests for Proposals or other solicitation documents, whichever is applicable, or any amendment to it, if the amendment is at issue): Any Proposer who is aggrieved in connection with a solicitation document shall file a written protest to SCDOT’s Chief Procurement Officer (CPO), PO Box 191, Columbia, SC 29202, within five business days of the date of posting of the solicitation, RFQ, RFP, or other solicitation document or any amendments to it on the SCDOT Design-Build Website.
- b. Protest of award: Any Proposer who is aggrieved in connection with the award of the contract shall file a written protest with the CPO within five business days of the date the Request for Concurrence in Award memo is posted on SCDOT Design-Build Website. Any matter that could have been raised pursuant to the Protest of Contents of Solicitation, section above, may not be raised as a protest of award.

- c. Exclusive remedy: The rights and remedies granted in this section to Proposers, either actual or prospective, are to the exclusion of all other rights and remedies of Proposers against the SCDOT.
- d. Failure to file a timely protest: If protestant fails to request a protest within the five business days, the award shall be final.
- e. Protest of shortlist: The number of Proposers shortlisted is not grounds for a protest.

## **2. SCDOT Procedures for Protest**

- a. Protest: A protest must be in writing, filed with the CPO, and set forth the grounds of the protest and the relief requested with enough specificity to give notice of the issues to be decided. The protest must be received by the CPO within the time provided.
- b. Burden of Proof: The protestant challenging SCDOT's action bears the burden of proving the decision is arbitrary.
- c. Duty and Authority to Attempt to Settle Protests: Before commencement of an administrative review, the CPO, or a designee of the CPO, may attempt to settle by mutual agreement a protest of an aggrieved Proposer, actual or prospective, concerning the solicitation or award of the contract. Any settlement reached by mutual agreement shall be approved by the CPO.
- d. Administrative Review and Decision: If, after reasonable attempt, a protest cannot be settled by mutual agreement, the CPO, or a designee, shall promptly conduct an administrative review. The CPO shall commence the administrative review no later than five business days after a reasonable settlement attempt and shall issue a decision in writing within five business days of completion of the review. The decision must state the reasons for the action taken. The decision shall include findings of fact and conclusions of law, separately stated. A copy of the decision along with a statement of appeal rights set forth below must be mailed or otherwise furnished immediately to the protestant.
- e. Finality of Decision and Appeal: The SCDOT's decision pursuant to the above paragraph is final and conclusive. A person adversely affected by the final decision can appeal to circuit court and hereby waives a trial by jury regarding any protest arising out of this procurement and any such trial will be a non-jury trial before the South Carolina Circuit Court in Richland County.
- f. Stay of Award: The contract award is stayed until issuance of a final decision by the SCDOT. Once a final decision is issued, the filing of a petition to appeal that decision does not itself stay enforcement of SCDOT's decision to award the contract. SCDOT may grant or the reviewing court may order, a stay upon appropriate terms.
- g. All Freedom of Information (FOIA) requests will be sent to the FOIA Officer in the SCDOT Office of Chief Counsel.

## 6. SELECTION OF CONTRACTOR

The Committee will present a report regarding their review of the proposals to SCDOT Deputy Secretary for Engineering and recommend selection of the Proposer with the lowest Total Adjusted Bid. Upon approval by the SCDOT Secretary of Transportation, SCDOT will offer a contract to the selected Proposer. However, if the parties are unable to execute a contract, SCDOT may offer a contract to the Proposer with the next lowest Total Adjusted Bid.

The Design-Build Agreement will be executed for the Total Cost to Complete as shown in the Cost Proposal Bid Form and the Project Construction Time will be the Total Number of Calendar Days from the Notice to Proceed to Substantial Work Completion of the Project. Construction time for the Project shall be established as shown on the Cost Proposal Bid Form.

## 7. GENERAL INFORMATION

1. SCDOT reserves the right to terminate the evaluation of one or more of the proposals if it is determined to be in the best interest of the state to do so.
2. SCDOT reserves the right, at its sole discretion, to either cancel this solicitation or to re-advertise in another public solicitation when it is in the best interest of the state to do so.
3. SCDOT reserves the right to reject any and all proposals, or parts thereof, and/or to discontinue contract execution with any party at any time prior to final contract execution.
4. SCDOT assumes no liability and will not reimburse costs incurred by firms, whether selected or not, in developing proposals or in contract execution.
5. SCDOT reserves the right to request or obtain additional information about any and all proposals. SCDOT may also issue addenda to the RFP, which will be posted on the website and emailed to all Proposers' Points of Contacts.
6. SCDOT reserves the right to revise or amend the RFP, specifications and/or drawings, including changes to the date the proposal is due. Such changes, if any, will be announced by an addendum or addenda to this Request for Proposal. All information relating to this RFP, including pertinent changes/addendums and other applicable information will be posted on SCDOT's Design-Build website [http://www.scdot.org/doing/constructionletting\\_designbuild.aspx](http://www.scdot.org/doing/constructionletting_designbuild.aspx) a minimum of ten business days prior to the date set for receipt of proposals as set forth in the Milestone Schedule. If changes are made to the RFP within ten days of the due date, Milestones may be adjusted accordingly. Proposers are strongly cautioned to check this site frequently to ensure they have the latest information.
7. Receipt of an addendum by the Proposer must be acknowledged in the space provided on the Addendum Notice to Proposer Transmittal Form posted on the SCDOT Design-Build website for this Project. Proposers shall submit the signed Notice with its Technical Proposal response to this RFP. Failure to acknowledge an addendum may result in rejection of the proposal. Explanations or instructions

given in a form other than an addendum or ATC response letter shall not be binding.

8. After award, if an unsuccessful Proposer would like to schedule a debriefing, Proposer shall submit a request within three business days from the date the award notification is posted on the SCDOT Design-Build website for this Project. Only written requests (emails are acceptable) for a debriefing will be scheduled. Failure to request a debriefing within the three business day period waives the opportunity for a debriefing.
9. Proposer shall be held responsible for the validity of all information supplied in its proposal, including that provided by potential subcontractors. Should subsequent investigation disclose that the facts and conditions were not as stated, the proposal may be rejected or contract terminated for default if after award, in addition to any other remedy available under the contract or by law.
10. Proposer, by submitting a proposal, represents that it has read and understands the RFP, its exhibits, attachments and addendums, and that its proposal is made in compliance with the criteria of the RFP. Proposers are expected to examine the RFP, its exhibits, attachments and addendums thoroughly and should request an explanation of any ambiguities, discrepancies, errors, omissions, or conflicting statements therein. Failure to do so will be at the Proposer's risk. Proposer assumes responsibility for any patent ambiguity in the RFP, its exhibits, attachments and addendums that Proposer does not bring to SCDOT's attention.
11. No proposal guaranty in the form of a Bid Bond is required for this procurement.
12. Proposal Acceptance Period - By submitting a proposal, Proposer agrees to hold the proposal offer available for acceptance a minimum of ninety calendar days after the Bid Opening date.
13. A business day is hereby defined as a day in which SCDOT Headquarters is open for business.

## 8. MILESTONE SCHEDULE

<b>Project Milestone</b>	<b>Date</b>
Provide RFP for Industry Review to Short-list Proposers	Friday, July 1, 2016
Deadline for Proposers to submit Comments/Questions on the RFP for Industry Review	Monday, July 25, 2016 by 7:30am EST
Open-Forum Meeting with Proposers for RFP for Industry Review Clarifications/Comments	Thursday, August 4, 2016 at 10:00am EST
Issue Final RFP	Friday, August 12, 2016
First Preliminary ATC Package and Submittal of Confidential Questions	Monday, August 22, 2016 by 7:30am EST
Second Preliminary ATC Package and Submittal of Confidential Questions	Monday, August 29, 2016 by 7:30am EST
Confidential Preliminary ATC Meetings with Proposers	Wednesday, September 7, 2016
Submittal of Non-Confidential Questions	Wednesday, September 14, 2016 by 2:00pm EST
Begin Formal ATC Process and Submittal of Confidential Questions	Wednesday, September 21, 2016
Submittal of Non-Confidential Questions	Wednesday, October 12, 2016
End Formal ATC Process	Wednesday, October 26, 2016
Submittal of Technical Proposals	Monday, November 28, 2016 by 2:00pm EST
Submittal of Cost Proposals	Monday, December 5, 2016 by 2:00pm EST
Bid Opening (with team representatives present)	Friday, December 16, 2016 at 10:00am EST
Notification of Intent to Award	Wednesday, December 21, 2016
Contract Execution	SCDOT Commission Meeting in January 2017

# 9. COST PROPOSAL BID FORM

## Interstate 26 Volvo Interchange Berkeley County

CONTRACTOR: \_\_\_\_\_

ADDRESS: \_\_\_\_\_

Provide full Project scope as described in Attachment A.

TOTAL COST TO COMPLETE (A) = \_\_\_\_\_

dc (Daily Cost of Project) = \$10,000

CONSTRUCTION TIME (b) IS DEFINED AS CALENDAR DAYS FROM NOTICE TO PROCEED TO SUBSTANTIAL WORK COMPLETION OF THE PROJECT.

Construction Time (Calendar Days) (b) = \_\_\_\_\_

Project Construction Time Cost (B) = \_\_\_\_\_

TOTAL BID (A+B) = \_\_\_\_\_

**No conditional Bids will be accepted. SCDOT reserves the right to delete any or all conditions placed on the Total Cost to Complete, and/or reserves the right to reject any Bid that is conditional or contains additions not called for in the plans and specifications.**

\_\_\_\_\_  
Signature

\_\_\_\_\_  
Date

\_\_\_\_\_  
Printed Name



# 10. NON-COLLUSION CERTIFICATION

## NON-COLLUSION CERTIFICATION

**Project ID: P028843**

IN ACCORDANCE WITH THE PROVISIONS OF S.C. CODE ANN. §§ 39-3-10 ET.SEQ., 39-5-10 ET. SEQ., 15 U.S.C. §45; 23 C.F.R. §635.112(F); AND 28 U.S.C. §1746, I HEREBY ACKNOWLEDGE THAT I AM AN OFFICER OF THE PROPOSER FIRM AND, UNDER PENALTY OF PERJURY UNDER THE LAWS OF THE UNITED STATES AND SOUTH CAROLINA, DECLARE, BY MY CERTIFICATION BELOW, THAT THE FOLLOWING IS TRUE AND CORRECT, AND FURTHER, THAT THIS FIRM, ASSOCIATION OR CORPORATION HAS NOT, EITHER DIRECTLY OR INDIRECTLY, ENTERED INTO ANY AGREEMENT, PARTICIPATED IN ANY COLLUSION, OR OTHERWISE TAKEN ANY ACTION IN RESTRAINT OF FREE COMPETITIVE BIDDING IN CONNECTION WITH THE SUBMISSION OF A BID PROPOSAL ON THE ABOVE REFERENCED PROJECT.

BY CHECKING THIS BOX  , I CERTIFY THAT I HAVE READ, UNDERSTAND, ACCEPT, AND ACKNOWLEDGE ALL OF THE ABOVE STATEMENTS.

Executed on \_\_\_\_\_  
(Date)

Signed: \_\_\_\_\_  
(Officer/Proposer)

\_\_\_\_\_  
(Title)

\_\_\_\_\_  
(Address)

\_\_\_\_\_

# 11. EQUAL EMPLOYMENT OPPORTUNITY CERTIFICATION

## (COMPLETE THIS SECTION FOR FEDERAL PROJECTS ONLY) EQUAL EMPLOYMENT OPPORTUNITY PERFORMANCE

Select the Certification that applies to the PROPOSER:

Certification (1)  or Certification (2)

Select the appropriate responses in the applicable Certification:

Certification (1): Pursuant to 41 C.F.R. §60-1.7(b)(1), Previous Equal Employment Opportunity Performance Certification, as the Prospective Prime Contractor, I HEREBY CERTIFY THAT I:

- (a) **(HAVE / HAVE NOT)** developed and filed an Affirmative Action Program pursuant to 41C.F.R. §60-2 and/or 60-4;
- (b) **(HAVE / HAVE NOT)** participated in a previous contract or subcontract subject to the equal opportunity clause;
- (c) **(HAVE / HAVE NOT)** filed with the Joint Reporting Committee, the Director of Office of Federal Contract Compliance, or the Equal Employment Opportunity Commission, all reports due under the applicable filing requirements,

OR

Certification (2): I, HEREBY CERTIFY that as the Prospective Prime Contractor submitting this Proposal, **(CLAIM / DO NOT CLAIM)** exemption from the submission of the Standard Form 100 (EEO-1) due to the fact that it employs a total of less than fifty (50) employees under C.F.R. §60-1.7, or qualifies for an exempted status under 41 C.F.R. §60-1.5.

I FURTHER CERTIFY that the above Certification will be made part of any Subcontract Agreement involved with this project.

Executed on \_\_\_\_\_, 20 \_\_\_\_ .

Signed: \_\_\_\_\_  
(Officer/PROPOSER)

Title: \_\_\_\_\_

Company: \_\_\_\_\_

Address: \_\_\_\_\_

Note: The above certification is required by the Equal Employment Opportunity Regulations of the Secretary of Labor (41 CFR 60-1.7(b)(1)), and must be submitted by PROPOSERS only in connection with contracts which are subject to the equal opportunity clause. Contracts that are exempt from the equal opportunity clause are set forth in 41 CFR 60-1.5. (Generally, only contracts of \$10,000 or under are exempt.)

Currently, Standard Form 100 (EEO-1) is the only report required by Executive Orders or their implementing regulations.

Proposers, Primary Members, or proposed Contractors and Consultants who have participated in a previous contract subject to the Executive Orders and have not filed the required reports shall note that 41 CFR 60-1.7(b)(1) prevents the award of contracts and subcontracts unless such contractor submits a report covering the delinquent period or such other period specified by the Federal Highway Administration or by the Director, Office of Federal Contract Compliance, U.S. Department of Labor.

# 12. STIPEND ACKNOWLEDGEMENT FORM

## Stipend Acknowledgement Form

### Interstate 26 Volvo Interchange Berkeley County

Proposer: \_\_\_\_\_

ADDRESS: \_\_\_\_\_

The undersigned Proposer, hereby:

Waives the stipend for this Project.

Accepts the stipend for this Project.

By accepting the stipend for this Project, Proposer agrees:

1) to execute and include the Stipend Agreement in Article XIII of the RFP with their RFP response;

2) SCDOT will pay the stipend to each eligible unsuccessful Proposer, who has signed a Stipend Agreement, within ninety (90) days after execution of the contract or the decision not to award a contract;

3) to transfer all rights to its Work Product used to develop the proposal as of the date of this acknowledgement. "Work Product" means all submittals, including ATCs, ideas, innovations, solutions, methods, processes, design concepts, materials, electronic files, marked up drawings, cross sections, quantity lists and intellectual property, made by Proposer during the RFP process, including the proposal, exchange of information during the pre-proposal and post-proposal period.

\_\_\_\_\_  
Date

\_\_\_\_\_  
Proposer

\_\_\_\_\_  
Print Name

# 13. STIPEND AGREEMENT

**STIPEND AGREEMENT**  
**Project ID: P028843**  
**Interstate 26 Volvo Interchange**  
**Berkeley County**

**THIS STIPEND AGREEMENT** (the “Agreement”) is made and entered into as of the \_\_\_ day of \_\_\_\_\_, 20\_, by and between the SOUTH CAROLINA DEPARTMENT OF TRANSPORTATION (hereinafter “SCDOT”), and \_\_\_\_\_ (“Proposer”), with reference to the following facts:

SCDOT issued a Request for Proposal (“RFP”) for design and construction of the above-referenced Design-Build Project (“Project”), pursuant to procurement authority granted in Section 57-5-1625 of the S.C. Code of Laws, 1976, as amended. The RFP provided for payment of stipends as provided herein.

**NOW, THEREFORE**, Proposer hereby agrees as follows:

## **1. Work Product.**

**1.1** Proposer shall prepare and submit a responsible and responsive technical and cost proposal that conforms in all material respects to the requirements and provisions of the RFP, as determined by SCDOT, and are timely received by SCDOT in accordance with the RFP Milestone Schedule.

**1.2** By signing this Stipend Agreement, Proposer agrees to transfer ownership to SCDOT of the electronic copy and hard copy of all Work Product used to develop the proposal. The Work Product (as defined below) shall become the property of SCDOT without restriction or limitation on its use, without further compensation or consideration, and can be used in connection with this Project or any future projects by SCDOT. Neither Proposer nor any of its team members shall copyright any of the material developed under this Agreement.

**1.3** The term “Work Product” shall mean all material, electronic files, marked up drawings, cross sections, quantity lists, submittals, alternative technical concepts (ATC), ideas, innovations, solutions, methods, processes, design concepts, and intellectual property, made by or produced for Proposer in the development and submission of the technical and price proposals, including exchanges of information during the pre-proposal and post-proposal period.

## **2. Compensation and Payment.**

**2.1** A stipend to Proposer for the Work Product described herein shall be \$70,000.00 and is payable on condition that Proposer (1) submitted a responsible and responsive technical and cost proposal to the RFP which is not selected for award of this Project, or (2) was awarded the Contract but the Contract was terminated by SCDOT at SCDOT’s convenience after the Submittal of Proposal Date (See Final RFP Milestone schedule) but prior to the Notice to Proceed #1. Responsibility and responsiveness of the proposal will be determined by SCDOT as a condition of payment.

**2.2** SCDOT will pay the stipend to Proposer under the following conditions:

(a) Within ninety (90) days after execution of the contract or the decision not to award a contract, SCDOT will pay the stipend to the unsuccessful Proposer meeting the criteria of Section 2.1, provided that the Proposer submitted a signed a Stipend Agreement with its response to the RFP.

(b) If the procurement is suspended or cancelled prior to the Proposal Due Date (see FINAL RFP Milestone schedule), no stipend will be paid to Proposer.

(c) After the submittal of proposals, but prior to award, if the procurement is cancelled, all Proposers that provide a responsive technical and cost proposal to the final RFP and submitted a signed Stipend Agreement with their RFP shall receive the stipend

(d) In the event of a Best and Final Offer, only one stipend will be paid.

(e) No stipends will be paid for submitting RFQ responses.

**2.3** Acceptance by the Proposer of payment of the stipend amount from SCDOT shall constitute a waiver by Proposer of any and all right, equitable or otherwise, to bring any claim in connection with this procurement, procurement process, award of the Contract, or cancellation of this procurement.

**2.4** The Proposer awarded the contract shall be not eligible to receive a stipend.

**2.5** If Proposer elects to waive payment of the stipend, SCDOT will not use the ideas or information contained in that Proposer’s proposal for this Project. However, the Proposer’s proposal will be subject to the South Carolina Freedom of Information Act.

**3. Indemnities.**

**3.1** Subject to the limitations contained in Section 3.2, Proposer shall indemnify, protect and hold harmless SCDOT and its directors, officers, employees and contractors from, and Proposer shall defend at its own expense, all claims, costs, expenses, liabilities, demands, or suits at law or equity arising in whole or in part from the negligence or willful misconduct of Proposer or any of its agents, officers, employees, representatives or subcontractors or breach of any of Proposer’s obligations under this Agreement.

**3.2** This indemnity shall not apply with respect to any claims, demands or suits arising from use of the Work Product by SCDOT.

**4. Compliance With Laws.**

**4.1** Proposer shall comply with all federal, state, and local laws, ordinances, rules, and regulations applicable to the work performed or paid for under this Agreement and covenants and agrees that it and its employees shall be bound by the standards of conduct provided in applicable laws, ordinances, rules, and regulations as they relate to work performed under this Agreement. Proposer agrees to incorporate the provisions of this paragraph in any subcontract into which it might enter with reference to the work performed pursuant to this Agreement.

**4.2** The Proposer agrees (a) not to discriminate in any manner against an employee or applicant for employment because of race, color, religion, creed, age, sex, marital status, national origin, ancestry or disability of a qualified individual with a disability; (b) to include a provision similar to that contained in subsection (a) in any subcontract; and (c) to post and to cause subcontractors to post in conspicuous places available to employees and applicants for employment, notices setting forth the substance of this clause.

**5. Assignment.**

Proposer shall not assign this Agreement without SCDOT’s prior written consent. Any assignment of this Agreement without such consent shall be null and void.

**6. Miscellaneous.**

**6.1** Proposer and SCDOT agree that Proposer, its team members, and their respective employees are not agents of SCDOT as a result of this Agreement.

**6.2** This Agreement, together with the RFP, as amended from time to time, the provisions of which are incorporated herein by reference, embodies the entire agreement of the parties. There are no promises, terms, conditions, or obligations other than those contained herein or in the RFP, and this Agreement shall supersede all previous communications, representation, or agreements, either verbal or written, between the parties hereto.

**6.3** It is understood and agreed by the parties hereto that if any part, term, or provision of this Agreement is by the courts held to be illegal or in conflict with any law of the State of South Carolina, the validity of the remaining portions or provisions shall not be affected, and the rights and obligations of the parties shall be construed and enforced as if the Agreement did not contain the particular part, term, or provisions to be invalid.

**6.4** This Agreement shall be governed by and construed in accordance with the laws of the State of South Carolina.

**IN WITNESS WHEREOF**, the parties have executed this Agreement as of the date first written above.

Witness:  
  
\_\_\_\_\_

SOUTH CAROLINA DEPARTMENT  
OF TRANSPORTATION

By: \_\_\_\_\_  
Chris Gaskins, P.E.  
Design-Build Engineer

Recommended:  
  
\_\_\_\_\_  
James (Jae) H. Mattox, P.E.  
Design-Build Program Manager

Proposer  
  
\_\_\_\_\_  
Name of Proposer

Witness:  
  
\_\_\_\_\_  
  
\_\_\_\_\_

By: \_\_\_\_\_  
  
Its: \_\_\_\_\_

# **AGREEMENT**

**AGREEMENT**  
**FOR THE DESIGN & CONSTRUCTION**  
**of**  
Interstate 26 Volvo Interchange

Berkeley County, South Carolina

*A DESIGN-BUILD PROJECT*

**BETWEEN**  
**SOUTH CAROLINA DEPARTMENT OF TRANSPORTATION**  
**AND**

\_\_\_\_\_ day of \_\_\_\_\_, 2017

Project ID P028843

## Table of Contents

<b>I.</b>	<b>CONTRACT DOCUMENTS.....</b>	<b>6</b>
<b>II.</b>	<b>PROJECT SCOPE .....</b>	<b>6</b>
	A. SCOPE OF WORK .....	6
	B. DESIGN AND CONSTRUCTION RESPONSIBILITIES .....	6
	C. DESIGN CRITERIA .....	7
	D. DESIGN REVIEW .....	8
	E. MAINTENANCE OF TRAFFIC .....	9
	F. OWNERSHIP OF DOCUMENTS.....	9
	G. CONSTRUCTION CRITERIA.....	10
	H. PROJECT MANAGEMENT.....	10
	I. CONTROL OF THE WORK .....	11
	J. CONTRACT DELIVERABLES .....	11
<b>III.</b>	<b>CONTRACT PRICE/CONTRACT PAYMENTS.....</b>	<b>13</b>
	A. CONTRACT PRICE .....	13
	B. CONTRACT PRICE ADJUSTMENTS.....	13
	C. CONTRACT PAYMENTS.....	15
	D. RETAINAGE.....	17
<b>IV.</b>	<b>CONTRACT TIME.....</b>	<b>18</b>
	A. PROJECT SCHEDULE .....	18
	B. CONTRACT TIME ADJUSTMENTS.....	20
	C. OWNER’S RIGHT TO STOP WORK .....	21
	D. LIQUIDATED DAMAGES.....	21
<b>V.</b>	<b>QUALITY ASSURANCE PROGRAM .....</b>	<b>22</b>
	A. CONTRACTOR’S RESPONSIBILITIES.....	22
	B. SCDOT RESPONSIBILITIES.....	23
	C. CONTRACTOR’S OBLIGATION .....	24
<b>VI.</b>	<b>INSURANCE AND BONDING.....</b>	<b>24</b>
	A. INSURANCE .....	24
	B. BONDING .....	28
<b>VII.</b>	<b>UTILITIES AND RAILROAD COORDINATION .....</b>	<b>28</b>
<b>VIII.</b>	<b>RIGHT OF WAY ACQUISITION .....</b>	<b>31</b>
	A. RIGHT OF WAY SERVICES .....	31
	B. ACQUISITION OF RIGHT-OF-WAY .....	35
<b>IX.</b>	<b>PERMITS .....</b>	<b>36</b>
<b>X.</b>	<b>ENVIRONMENTAL COMPLIANCE .....</b>	<b>36</b>
	A. COMPLIANCE WITH ENVIRONMENTAL COMMITMENTS .....	36
	B. PRECONSTRUCTION / PARTNERING CONFERENCE(S) .....	37
	C. PROTECTION OF ARCHEOLOGICAL AND PALEONTOLOGICAL REMAINS AND MATERIALS .....	37
	D. COMMUNITY AND PUBLIC RELATIONS PLAN .....	38
<b>XI.</b>	<b>HAZARDOUS MATERIALS.....</b>	<b>38</b>



<b>XIII. DIFFERING SITE CONDITIONS .....</b>	<b>40</b>
<b>XIV. FORCE MAJEURE.....</b>	<b>41</b>
<b>XV. WARRANTY .....</b>	<b>41</b>
<b>XVI. INDEMNITY.....</b>	<b>42</b>
<b>XVII. TERMINATION AND CANCELLATION.....</b>	<b>42</b>
A. TERMINATION FOR DEFAULT .....	42
B. TERMINATION FOR CONVENIENCE .....	44
<b>XVIII. DISADVANTAGED BUSINESS ENTERPRISES .....</b>	<b>44</b>
<b>XIX. ON-THE-JOB TRAINING REQUIREMENTS .....</b>	<b>44</b>
<b>XX. RECORD RETENTION .....</b>	<b>45</b>
<b>XXI. AS-BUILTS .....</b>	<b>45</b>
<b>XXII. ESCROW PROPOSAL DOCUMENTS.....</b>	<b>46</b>
<b>XXIII. DISPUTE RESOLUTION .....</b>	<b>46</b>
<b>XXIV. SCDOT'S AGENT .....</b>	<b>47</b>
<b>XXV. ASSIGNABILITY.....</b>	<b>47</b>
<b>XXVI. GENERAL PROVISIONS.....</b>	<b>47</b>
<b>CERTIFICATION OF CONTRACTOR .....</b>	<b>50</b>
<b>CERTIFICATION OF DEPARTMENT .....</b>	<b>51</b>
<b>DRUG-FREE WORKPLACE CERTIFICATION .....</b>	<b>52</b>

## **LIST OF EXHIBITS**

1. Cost Proposal Bid Form
2. Schedule of Values
3. Scope of Work
4. Project Design Criteria
  - 4a. Roadway Design Criteria
  - 4b. Structures Design Criteria
  - 4c. Pavement Design Criteria
  - 4d. Traffic Design Criteria
    - Part 1 – Signing and Pavement Marking
    - Part 2 – Work Zone Traffic Control
  - 4e. Hydraulic Design Criteria
  - 4f. Geotechnical Design Criteria
  - 4g. Environmental Design Criteria
5. Special Provisions and Contract Requirements

I-26 Volvo Interchange  
Berkeley County

WHEREAS, on November 17, 2015, the South Carolina Department of Commerce (SCDOC) and the South Carolina Department of Transportation (SCDOT) entered into an intergovernmental agreement in which the SCDOC requested the assistance of SCDOT to accomplish the design and construction of the I-26 Volvo Interchange Project in Berkeley County of the State of South Carolina, (hereinafter “the Project”); and

WHEREAS, the South Carolina Department of Transportation, as an agency of the State of South Carolina, wishes to enter into a design build construction agreement and administer the Project on behalf of the SCDOC in accordance with the terms of the intergovernmental agreement; and

WHEREAS, the South Carolina Department of Transportation, as a servant of the people of the State of South Carolina, wishes to see this strategic project completed; and

WHEREAS, limitations imposed by traditional methods of designing, and constructing highways would mean that the Project could be completed only after an unacceptable delay; and

WHEREAS, pursuant to Section 57-5-1625 SC Code of Law, the South Carolina Department of Transportation desires to award a highway construction contract using a Design / Build procedure; and

WHEREAS, after a competitive process, CONTRACTOR has been selected to participate in this venture by designing and building the Project; and

WHEREAS, the South Carolina Department of Transportation wishes to avail itself of and rely on CONTRACTOR’s expertise and proven track record in designing and constructing such projects, on time and within budget; and

WHEREAS, CONTRACTOR wishes to provide that expertise and to participate in this venture for the good of the people of the State of South Carolina;

NOW THEREFORE, this Agreement is executed and made, effective as of the Effective Date as defined herein, between the SOUTH CAROLINA DEPARTMENT OF TRANSPORTATION (“SCDOT”) and \_\_\_\_\_ (“CONTRACTOR”). In consideration of the covenants hereinafter set forth, the parties hereto mutually agree as follows:

## **I. CONTRACT DOCUMENTS**

The Contract shall be composed of this Agreement and all exhibits, SCDOT's Request for Proposals and all attachments, Request for Qualifications and all attachments, CONTRACTOR's Proposal and all attachments, and CONTRACTOR'S Qualifications and all attachments. In case of conflict, the order of precedence of the Contract documents shall be: (1) this Agreement; (2) Agreement Exhibits; (3) SCDOT Request for Proposals (RFP) document and Attachment B; (4) CONTRACTOR's Proposal and attachments; and (5) SCDOT Request for Qualifications (RFQ) and CONTRACTOR's Statement of Qualifications (SOQ). In the event of a conflict between the Project Criteria and Special Provisions identified in the Agreement Exhibits, the order of precedence shall be (1) the Project Criteria and (2) Special Provisions. Attachment C is the project information package and is provided for information only. SCDOT shall not be liable for the accuracy of the information contained therein.

## **II. PROJECT SCOPE**

### **A. Scope of Work**

CONTRACTOR shall furnish all services, labor, materials, equipment, supplies, tools, transportation, and coordination required to perform all design, preliminary engineering, surveying, geotechnical services, scheduling, permitting, right of way services, procurement, construction, utility coordination, demolition, material disposal and any other services necessary to perform the Project as defined in the Project Scope of Work made a part hereof as **EXHIBIT 3**.

### **B. Design and Construction Responsibilities**

1. CONTRACTOR, consistent with applicable state licensing laws, shall provide, through qualified South Carolina licensed design professionals employed by CONTRACTOR or procured from qualified, independent South Carolina licensed design consultants, the necessary design work, including, but not limited to, surveys, right of way services, roadway design, maintenance of traffic, geotechnical exploration and design, hydraulic analyses, storm water management, erosion control, superstructure design, and foundation and substructure design including seismic analyses for the preparation of the required drawings, specifications and other design submittals to permit CONTRACTOR to complete the work in accordance with the Contract.
2. CONTRACTOR shall provide through itself or subcontractors the necessary supervision, labor, inspection, testing, material, equipment, machinery, temporary utilities and other temporary facilities to permit performance of all demolition, earthwork, drainage, foundation work, maintenance of traffic, roadway work, structural work, excavation, erosion and sediment control work, field layout work, construction management and inspection, utility coordination and relocation, railroad coordination, CONTRACTOR quality control, and all other work necessary to complete construction of the Project in accordance with the Contract. CONTRACTOR shall perform all design and construction activities efficiently

and with the requisite expertise, skill and competence to satisfy the requirements of the Contract. CONTRACTOR at all times shall exercise control over the means, methods, sequences and techniques of construction. CONTRACTOR's operations and construction methods shall comply with all applicable federal, state and local regulations with regard to worker safety, protection and health and protection of the environment and applicable permit requirements.

3. CONTRACTOR shall design and construct the project in such a manner that the construction limits are contained within the approved environmental footprint to the extent possible. Where new right of way is required to construct the Project, the CONTRACTOR shall design and construct the Project so as to minimize the additional rights of way needed. The acquisition of rights of way, including both cost and services to acquire, shall be the responsibility of the CONTRACTOR and shall be done in accordance with Article VIII of this Agreement. CONTRACTOR shall furnish the SCDOT a copy of any agreements for the use of additional properties not acquired as right of way that are used in conjunction with the construction of this Project. CONTRACTOR shall abide by the provisions of all applicable environmental permits, any conditions of individual right of way agreements, and all environmental commitments. The CONTRACTOR shall sign the Contractor Certification Form and this agreement will be made part of the contract.
4. It shall be the responsibility of CONTRACTOR to determine and comply with all applicable federal, state, and local laws in connection with the services set forth in this Contract. This obligation shall include, but not be limited to, procurement of all permits and licenses not obtained by SCDOT provided, however, that with respect to any permit or licenses that must be obtained in the name of SCDOT, CONTRACTOR shall perform all functions within its power to obtain the permit, including mitigation, and SCDOT will fully cooperate in this effort and perform any functions that must be performed by SCDOT. CONTRACTOR shall be responsible for payment of all charges, fees, and taxes, and for providing all notices necessary and incident to the performance of the Project as of the Effective Date of this Agreement. The Contract Price shall include fees related to the above obligations and if any fees are waived by the regulatory or governmental entity, then the amount of the fee waived shall be deducted from the Contract Price.

### **C. Design Criteria**

It shall be the responsibility of CONTRACTOR to design all aspects of the Project in accordance with the contract documents. For the Project, CONTRACTOR shall provide a completed set of construction plans signed and sealed by a licensed professional engineer in South Carolina. CONTRACTOR shall be fully responsible for the accuracy of the design and compliance with specifications, standards and Project Criteria.

### **D. Design Review**

1. Prior to the Preconstruction Meeting, CONTRACTOR shall provide a Draft Design Review Submittal Schedule to SCDOT. The Design Review Submittal Schedule shall include a Gantt chart of the submittals and will serve as the basis for reviewing the design and construction plans. The Design Review Submittal Schedule and Gantt chart shall be updated and included with each submittal package if any changes to the schedule occur. CONTRACTOR, CONTRACTOR'S design consultant, subcontractors, suppliers and SCDOT shall discuss the schedule and procedures for submitting design plans at the Preconstruction Meeting. CONTRACTOR, CONTRACTOR'S design consultant, subcontractors and suppliers shall not submit any design work until the Design Review Submittal Schedule is approved by SCDOT. All subsequent changes to the schedule shall be approved by SCDOT.
2. All submittals and supporting documentation shall be uploaded electronically to ProjectWise and an email shall be sent to SCDOT that verifies the contents of the upload. A complete package shall be limited to one phase (ex. Preliminary/ROW/Final/RFC) of one segment or structure and include all deliverables specified in Exhibit 4. Prior to beginning any construction activities, permanent or temporary, the Transportation Management Plan and Conceptual Work Zone Traffic Control plans for the entire project shall be submitted by the CONTRACTOR and approved by SCDOT. If approved by SCDOT, one Maintenance of Traffic package, including, but not limited to, an NPDES permit application and related plans, may be allowed to provide the opportunity to begin construction of non-permanent work items, such as clearing and grubbing, shoulder strengthening, minor demolition not adversely impacting traffic or operations, etc.
3. CONTRACTOR shall provide plans, reports, and documents as defined in Exhibit 4. Prior to commencement of permanent construction activities, SCDOT will have the right, but not the obligation, to review and comment upon all submittals. The review period will begin the first business day after the submittal package is uploaded to ProjectWise. No more than one package shall be submitted within a five business day period. The initial review period for each submittal package shall be 15 business days. SCDOT reserves the right to return any submittal package that is deficient or incomplete to the extent that it does not comply with Section II, B, 1 and/or does not demonstrate design can be completed in accordance with the Contract. Returned submittals must be revised and uploaded to ProjectWise. Another 15 business day review period will be allowed for resubmittals. SCDOT review comments will be sent to the CONTRACTOR, who shall respond in written form within five business days and prior to subsequent phase submittals. SCDOT will then status CONTRACTOR'S comments and may provide further comments within five business days. Contractor shall clearly identify and describe any changes made to a submittal that are unrelated to SCDOT review comments. Review comments for all phases of each segment or structure shall be closed before the associated RFC plans are approved and prior to commencement of construction, demolition or disposal activities. After comments are closed, any changes made to plans may, at the sole discretion of

SCDOT, require a new initial submittal and require adjustment to the CONTRACTOR's submittal schedule. This review and comment is fully discretionary, however no review or comment nor any failure to review or comment shall operate to absolve CONTRACTOR of its responsibility to design and build the Project in accordance with the contract or to shift responsibility to SCDOT.

#### **E. Maintenance of Traffic**

The SCDOT work zone mobility requirements found within the documents known as *Rule on Work Zone Safety and Mobility: The Policy for South Carolina Department of Transportation* and *Rule on Work Zone Safety and Mobility: Implementation, Maintenance, and Safety Guidelines* shall apply to this project. These requirements apply to the CONTRACTOR, all subcontractors, all SCDOT staff and designated representatives acting on behalf of the SCDOT performing duties with responsibilities relative to a work zone, including but not limited to planning, project development, design, construction, and maintenance.

The CONTRACTOR shall design, develop, implement and maintain a set of coordinated strategies to manage the work zone impacts of the project designated as the Transportation Management Plan (TMP). These strategies will include a Temporary Traffic Control plan, a Transportation Operations component, and a Public Information component. The Policy and the anticipated work zone impacts of the project shall determine the level of detail, content, and scope of the TMP. The primary component, the Temporary Traffic Control plan shall address traffic control and safety throughout and adjacent to the project site. A secondary component, the Transportation Operations plan, will address management of traffic operations in the project site and all adjacent areas impacted by the project. The final component, the Public Information plan, addresses communications with the public and entities impacted by the project. The CONTRACTOR's Transportation Management Plan and its components shall comply with the requirements of this Agreement and subsequent Exhibits, Part 6 of the Manual on Uniform Traffic Control Devices (MUTCD) latest edition, and SCDOT policies, standard specifications and all addendums to the standard specifications, the typical traffic control standard drawings for road construction, and procedures. All components of the TMP prepared by the Contractor are required. The TMP with all components shall be submitted to SCDOT for review and must be approved by SCDOT before construction activities can begin.

#### **F. Ownership of Documents**

Drawings, specifications, test data, inspection reports, QC documents, daily diaries and any other documents, including those in electronic form, prepared by CONTRACTOR or CONTRACTOR's consultants are "Project Documents". CONTRACTOR and CONTRACTOR's consultants shall be the owner of the Project Documents. Upon the Effective Date of this Agreement, CONTRACTOR grants SCDOT a nonexclusive license to reproduce the Project Documents for the purposes of, but not limited to, promoting, using, maintaining, upgrading, or adding to the Project. Upon completion of the Project or upon default by CONTRACTOR,

CONTRACTOR shall provide copies of all Project Documents to SCDOT in the format designated by SCDOT.

#### **G. Construction Criteria**

CONTRACTOR shall construct the Project in accordance with all applicable Federal, State, and local statutes and regulations. All construction shall be performed in accordance with the following criteria, which are incorporated herein by reference and made a part hereof. The construction criteria are intended to be complementary and to describe and provide for a complete work. Where the following construction criteria conflict, the order of precedence shall be as listed below:

1. **EXHIBIT 4** – Project Design Criteria
2. **EXHIBIT 5** – Special Provisions
3. Final Construction Plans provided by SCDOT
4. SCDOT Standard Drawings, effective as of the most recent Standard Highway Letting prior to the release of the Final RFP (see Design Build Website - [http://www.scdot.org/doing/constructionLetting\\_DesignBuild.aspx](http://www.scdot.org/doing/constructionLetting_DesignBuild.aspx))
5. SCDOT Supplemental Specifications and Supplemental Technical Specifications, effective as of the release of the Final RFP (see Design Build Website - [http://www.scdot.org/doing/constructionLetting\\_DesignBuild.aspx](http://www.scdot.org/doing/constructionLetting_DesignBuild.aspx))
6. SCDOT Standard Specifications for Highway Construction, effective as of the release of the Final RFP (see Design Build Website - [http://www.scdot.org/doing/constructionLetting\\_DesignBuild.aspx](http://www.scdot.org/doing/constructionLetting_DesignBuild.aspx))
7. SCDOT Construction Manual, effective as of the release of the Final RFP
8. SCDOT Approval Sheets, Material Acceptance Policies and New Products Evaluation Summary (available on SCDOT internet website)

#### **H. Project Management**

1. CONTRACTOR shall be responsible for ensuring that the Project is constructed in conformance with the Contract, all referenced documents and specifications, and applicable laws and regulations.
2. CONTRACTOR shall provide project management services sufficient to supervise the activities of his own personnel and subcontractors. CONTRACTOR shall provide a sufficient number of persons on site, to the satisfaction of SCDOT, to provide for the construction management of the Project.
3. SCDOT will provide representatives assigned to the Project to monitor the construction and provide necessary coordination between SCDOT and



CONTRACTOR. All costs for salary and equipment to maintain SCDOT employees will be provided by SCDOT at no expense to CONTRACTOR. SCDOT and Federal Highway Administration (FHWA) representatives will have full and complete access to the Project, the work in progress, the “Daily Diaries”, and to other technical documents and project records associated with design, construction, demolition, material disposal, materials, quality control, materials installation, and testing. SCDOT representatives will receive reasonable notice of and have the opportunity to participate in any meetings that may be held concerning the Project or the relationship between CONTRACTOR and their consultants and subcontractors when such meetings are associated with technical matters, progress, or quality of the Project. As used in this paragraph, “notice” shall require actual written notice to SCDOT’s Agent.

#### **I. Control of the Work**

1. CONTRACTOR shall determine the appropriate means, methods and scheduling necessary to complete the work timely and in accordance with all construction requirements. SCDOT and FHWA will have the right to review and inspect the work at any time.
2. If, at any time, SCDOT observes or has actual notice of any fault or defect in CONTRACTOR’s performance of this Agreement, SCDOT will give CONTRACTOR prompt written notice reasonably detailing the nature of the fault or defect. SCDOT is not required to discover or to accept defective or faulty work. SCDOT’s right to have defective or faulty work promptly corrected shall not be waived by any action of SCDOT.
3. SCDOT will have the authority to suspend the work, wholly or in part, for such periods, as SCDOT may deem necessary, due to CONTRACTOR’s failure to meet the requirements of the Contract in the performance of the work.
4. No inspection, acceptance, payment, partial waiver, or any other action on the part of SCDOT will operate as a waiver of any portion of this Agreement or of any power reserved herein or any right to damages or other relief, including any warranty rights, except insofar as expressly waived by SCDOT in writing. SCDOT will not be precluded or estopped by anything contained herein from recovering from CONTRACTOR any overpayment as may be made to CONTRACTOR.

#### **J. Contract Deliverables**

CONTRACTOR shall submit deliverables including, but not limited to, the following as set forth in the CONTRACT. All deliverables shall contain proper references to both the Contract ID number and the appropriate Project ID number for that specific location. Deliverables noted below with an asterisk shall be included in the Design Review Submittal Schedule and follow Design Review procedures as outlined in Section II.D of the Agreement.

1. Contract Deliverable Matrix
2. All deliverables as specified in **EXHIBIT 4 \***
3. CPM Schedule, as specified in **Article IV**
4. Design Review Submittal Schedule including Gantt Chart of Submittals\*
5. Schedule of Values, as specified in **EXHIBIT 2**
6. Design QC Plan\*
7. Construction QC Plan
8. Transportation Management Plan (TMP), as specified in **Article II**
9. Clearing and Grubbing Plan
10. CONTRACTOR's Erosion Control Plan
11. SCDHEC Notice of Intent (NOI) for Stormwater Discharges Covered Under SC NPDES Construction General Permit SCR160000) & Storm Water Pollutant Prevention Plan and signed Contractor Certification Form (SCDHEC 0437)
12. Wetland and Stream Mitigation
13. Crane Operator Documents
14. Community and Public Relations Plan, as specified in **Article X** and **EXHIBIT 5**
15. EEO, DBE, and OJT Requirements, as specified in **Article XVIII & EXHIBIT 5**
16. Right-of-Way documents, as specified in **Article VIII**
17. Escrow Proposal Documents
18. CONTRACTOR's Materials Certification
19. Railroad Coordination Documents & Insurance Certificates per **EXHIBIT 6**
20. HAZMAT surveys for structures not already surveyed, SCDHEC Notice of Demolition for RCE Signature
21. Utility Coordination Reports, including Utility Agreements, and Supporting Documentation
22. Right of Way Plats and Monuments (per Preconstruction Advisory Memorandum #8)

23. Shop Plans and Working Drawings

24. As-Built Plans

### III. CONTRACT PRICE/CONTRACT PAYMENTS

#### A. Contract Price

The “Contract Price” shall be \$\_\_\_\_\_. In consideration for the Contract Price, CONTRACTOR shall perform all of its responsibilities under the Contract. The Contract Price shall include all work identified in the Agreement and subsequent Exhibits and as identified in the Cost Proposal Bid Form – **EXHIBIT 1**.

#### B. Contract Price Adjustments

##### 1. Allowable adjustments

The Contract Price may be adjusted to reflect the direct costs, plus an additional amount not to exceed 10% of the direct costs for the combined total of reasonable overhead\* and profit, associated with any of the following:

- a. Amount added or deducted as the result of a “Change” or “Construction Change Directive”.
- b. Differing site condition as defined in Article XIII.
- c. Intentional or bad faith acts or omissions by SCDOT that unreasonably interfere with CONTRACTOR’s performance and cause delay of work on the critical path of the Project.
- d. Changes in legal requirements or regulations that are effective subsequent to the date of this Agreement.
- e. Discovery of hazardous materials not previously identified as set forth in Article XI
- f. Discovery of archeological or paleontological sites not previously identified as noted in Article X.
- g. Premium right-of-way costs and second appraisals as set forth in Article VIII. Only the actual premium right-of-way and actual second appraisal cost will be reimbursed. No additional amount for overhead, profit, bonds and insurance will be considered for this item.

\*Overhead: The operating expense of a business exclusive of direct cost labor and material.

Other than as provided above, the Contract Price shall not be increased for contract time adjustments or delay damages. Contract Price adjustments shall be

documented by Supplemental Agreement signed by both parties and shall be reflected immediately in the Schedule of Values. No claim by the CONTRACTOR for an adjustment hereunder shall be allowed if notice is not given prior to final payment under this Agreement.

## 2. Changes

- a. A “Change” shall be any deviation or variation from the Project Scope or the Project Criteria. No Change shall be implemented without the express written approval of SCDOT. A “Change” may be an “Additive Change” or a “Deductive Change”.
- b. SCDOT may initiate a change by advising CONTRACTOR in writing of the change. As soon thereafter as practicable, CONTRACTOR shall prepare and forward to SCDOT an estimate of cost or savings, and the impact to the schedule resulting from the change. SCDOT will advise CONTRACTOR in writing of its approval or disapproval of the change via “Issue Paper”. If SCDOT approves the change, CONTRACTOR shall perform the Services as changed.

## 3. Construction Change Directive

A Construction Change Directive is a written order from SCDOT directing a change prior to agreement with CONTRACTOR on adjustment, if any, to the Contract Price or Contract Time. If a price for the work cannot be agreed upon, CONTRACTOR shall perform the work under Force Account Procedures as outlined in Section 109.5 of SCDOT’s Standard Specifications.

## 4. Direct Costs

For the purpose of a Contract Price Adjustment, “Direct Costs” shall be defined as:

- a. Costs of labor, including social security, old age and unemployment insurance, fringe benefits required by agreement or custom, and workers’ compensation insurance;
- b. Costs of materials, supplies, and equipment, including cost of transportation, whether incorporated or consumed;
- c. Actual costs of machinery and equipment owned by CONTRACTOR or any affiliated or related entity exclusive of hand tools;
- d. Actual costs paid for rental of machinery and equipment exclusive of hand tools;
- e. Costs of premiums for all bonds and insurance, permit fees, and sales, use or similar taxes;

- f. Additional costs of supervision and field office personnel directly attributable to the change or event; and
- g. Costs incurred or fees paid for design work related to the change or event.

### C. Contract Payments

#### 1. Schedule of Values

Prior to execution of this Agreement, CONTRACTOR shall provide a Schedule of Values acceptable to SCDOT and work may not start until the Schedule of Values is approved by SCDOT. The Schedule of Values will serve as the basis for cost loading of the CPM Schedule. The CPM schedule shall include sufficient information to provide for monetary and quantitative tracking of the work by SCDOT. Updates to the cost-loaded CPM schedule will serve as the basis for progress payments requested by and made to CONTRACTOR. If the Contract Price is adjusted, CONTRACTOR shall revise its Schedule of Values and the CPM Schedule to reflect the adjustment in the Contract Price. The revised Schedule of Values must be approved by SCDOT prior to the time for the subsequent request for a progress payment otherwise no progress payments will be made. The Schedule of Values shall be incorporated herein as **EXHIBIT 2**. The Schedule of Values should include Lump Sum items that will serve as measurement and payment for any item referred to in this Contract as a “contract unit bid price” item.

#### 2. Mobilization

Mobilization shall not exceed 5% of the Total Contract Cost as shown in the Schedule of Values. Mobilization will be paid in two (2) equal installments. The first will be paid in the progress payment immediately following Notice to Proceed, and the second will be paid at the start of construction. CONTRACTOR is also entitled to Mobilization –Subcontractor as defined in **EXHIBIT 5**.

#### 3. Periodic Progress Payment Applications

No application for payment of the Contract Price shall be submitted until SCDOT gives a notice to proceed. Applications for payment of the Contract Price may be submitted once a month. Each application for payment of the Contract Price shall set forth, in accordance with the Schedule of Values and the cost-loaded CPM schedule, the percentage of all items comprising the work completed since CONTRACTOR’s immediately prior request for payment. The application for payment of the Contract Price may also request payment for equipment and materials not yet incorporated into the Project, provided that (i) SCDOT is satisfied that the equipment and materials are suitably stored at either the Project or another acceptable location, (ii) the equipment and materials are protected by suitable insurance and (iii) upon payment, SCDOT will receive title to the equipment and materials free and clear of all liens and encumbrances.

4. Periodic Progress Payments

SCDOT will review each application for payment. Upon approval by SCDOT of an application for payment, SCDOT will pay CONTRACTOR the undisputed percentage for the Project completed during the period covered by the application for payment. SCDOT will make each payment within twenty-one (21) days of the receipt of the corresponding Application for Payment. In the event of a dispute over the quality of work or percentage of the Project completed, SCDOT's decision is controlling and final. Payment by SCDOT will not preclude or estop SCDOT from correcting any measurement, estimate, or certificate regarding the percentage completion of the Project, and future payments may be adjusted accordingly.

5. Prompt Payment of Subcontractors

- a. Subject to the provisions on retainage provided in Paragraph (b) below, when a subcontractor has satisfactorily performed a work item of the subcontract, CONTRACTOR must pay the subcontractor for the work item within seven (7) calendar days of CONTRACTOR's receipt of payment from SCDOT. A subcontractor shall be considered to have "satisfactorily performed a work item of the subcontract" when SCDOT pays CONTRACTOR for that work item.
- b. CONTRACTOR may withhold as retainage up to five (5%) percent of a subcontractor's payment until satisfactory completion of all work items of the subcontract. "Satisfactory completion of all work items of the subcontract" shall mean when SCDOT pays CONTRACTOR for the last work item of the subcontract. CONTRACTOR must release to the subcontractor any retainage withheld within seven (7) calendar days from the date CONTRACTOR receives payment from SCDOT for the last work item of the subcontract. For further information regarding Retainage, see Article III, paragraph D.
- c. With each progress payment application, CONTRACTOR shall certify to SCDOT that the payment application is complete and that all subcontractors have been paid for work covered by previous applications.
- d. Failure to comply with any of the above provisions shall result in one or more of the following sanctions: (1) no further payments to CONTRACTOR unless and until compliance is achieved; (2) CONTRACTOR being placed in default; and/or (3) CONTRACTOR being declared delinquent, such delinquency being subject to procedures and penalties provided in 108.8 of the Standard Specifications.

6. Withholding of Payment

SCDOT may withhold all or part of any payment under the Contract because for any of the reasons listed below. Any funds withheld will be released upon CONTRACTOR satisfactorily remedying the defect, fault, or failure and will be included in the next regularly schedule pay estimate. Payment will be subject to retainage if applicable.

- a. Defective work not remedied. Any such withholding, however, shall not exceed two times the reasonable cost of remedying the defective work. Defective work shall be defined as work or material not conforming to the requirements of the Contract.
- b. Reasonable evidence that the Work will not be Substantially Complete within the Contract Time as adjusted and that the unpaid balance of the Contract Price will not be adequate to cover Liquidated Damages for the actual unexcused delay;
- c. Failure to comply with the prompt payment provision of this Contract;
- d. Any fines or other charges to SCDOT due to CONTRACTOR's failure to comply with permit requirements or other regulations;
- e. Notice of cancellation of insurance;
- f. Failure to submit updated and approved CPM or Schedule of Values;
- g. Violation of QC plan requirements;
- h. Failure to follow specifications or procedures required by the Contract;
- i. Failure to comply with DBE, On-The-Job training, or Pre-Employment Training provisions;
- j. Failure to provide adequate work zone traffic control;
- k. Failure to provide adequate sediment and erosion control; or,
- l. Violation of any contract provisions.

#### **D. Retainage**

Provided the Project is proceeding satisfactorily, SCDOT will not withhold retainage. However, if at any time SCDOT determines that CONTRACTOR fails to meet contract terms or the Project is not proceeding satisfactorily, SCDOT may retain up to 10% of the Contract Price as retainage. If the reason for SCDOT's withholding of retainage is attributable to a subcontractor's failure to perform, CONTRACTOR may withhold up to 10% of the subcontractor's payment until all work of the subcontract work is satisfactorily performed. If it decides to withhold retainage, SCDOT will not withhold more than 20% of any single payment application. SCDOT will have sole authority to determine the amount (not exceeding 10%) and necessity of retainage.

## IV. CONTRACT TIME

### A. Project Schedule

1. Time for Completion of Project:

Construction Time: The Project shall be Substantially Complete within \_\_\_\_\_ calendar days from Notice to Proceed. The Notice to Proceed shall be no later than 45 days from the effective date of the Agreement. The PROPOSER must identify the time required for the Construction Time of the Project on the Cost Proposal Bid Form (identified as “b” on the bid form). Final Completion shall be reached as defined in Paragraph 4 below.

Contract Time: Contract Time shall be the number of calendar days from Notice to Proceed to Substantial Work Completion which corresponds to the Construction Time as defined on the Cost Proposal Bid Form in **EXHIBIT 1** plus the time from Substantial Work Completion to Final Completion, not to exceed 180 days. Time is of the essence.

Substantial Work Completion: The Project shall be considered substantially complete when it is serviceable to the public, all lanes and ramps are open, and all work is completed except for “Project Close-out Activities”, “Project Close-out Activities” are defined as punch list items, site clean-up, demobilization, and final Project documentation, including but not limited to as-built plans.

2. Critical Path Method Schedule: CONTRACTOR shall prepare and maintain a schedule for the Project using the Critical Path Method of scheduling (hereinafter called “CPM Schedule”). Prepare a Level II CPM Schedule in accordance with this agreement and the SCDOT Supplemental Specifications with the following exceptions:

- a. Submit to the SCDOT the initial baseline CPM schedule within 30 days from the Effective Date of this Agreement. No contract payment will be made to Contractor and no construction work may begin until a CPM baseline schedule is received and accepted by SCDOT. Update the baseline CPM schedule for monetary and quantitative tracking purposes as Released for Construction plans are developed.
- b. Cost-load the CPM schedule using the expenses identified in the schedule of values. Use the schedule of values to establish Expense Categories and assign to the correct activities.
- c. Include submittal activities. Allow duration for these activities to include SCDOT review periods.
- d. Reuse of deleted activity ID’s from schedule update to schedule update is not allowed.



- e. Failure to include any element of work or any activity including but not limited to utility relocation, right of way acquisition, and permitting will not relieve the CONTRACTOR from completing all work within the Contract Time at no additional time or cost to the SCDOT, notwithstanding the acceptance of the schedule by SCDOT.
  - f. Develop project specific calendars reflecting all seasonal restrictions included in this Agreement and non-work days. Address durations for weather within activity duration, not within the calendar.
  - g. Use only a Work Breakdown Structure (WBS) to organize schedule activities. At a minimum, breakout the design and construction phases. These two breakouts should have the same parent within the structure.
  - h. Submit monthly updates no later than 15 days following the most recent estimate period end date, whether or not an estimate was generated. Set the data date the same as the most recent estimate period end date.
  - i. If SCDOT determines any schedule submission is deficient, it will be returned to the CONTRACTOR. A corrected schedule shall be provided within 7 calendar days from the SCDOT's transmittal date.
  - j. The schedule may indicate an early completion date. However, SCDOT will not be liable in any way for CONTRACTOR's failure to complete the Project prior to the specified Contract Time. Any additional costs, including extended overhead incurred between CONTRACTOR's scheduled completion date and the Contract Time, shall be the responsibility of the CONTRACTOR.
  - k. The schedule may include constraints to indicate the early completion of portions of the work. SCDOT will remove these constraints when determining the critical path of the schedule.
  - l. Include in each narrative a detailed listing of crews utilized on activities and their responsibilities. In lieu of this, the Contractor may request to submit a Resource Loaded CPM schedule.
3. Progress Review Meetings:
- a. Review Meetings shall be held between CONTRACTOR and SCDOT at least every 2 weeks. Periodic construction meetings shall be held by CONTRACTOR with its consultants and subcontractors to coordinate the work, update the schedule, provide information and resolve potential conflicts.
  - b. SCDOT and CONTRACTOR will hold a regular CPM Progress Meeting at which all principal parties are expected to attend. These meetings will be held the week before the application for payment is due so that job progress will coincide with the payment application. At this meeting, CONTRACTOR shall provide the most recent schedule with notations showing actual start dates,

actual finish dates, and activity progress. If the schedule provided indicates an actual or potential delay to the completion of the Contract, CONTRACTOR shall provide a narrative identifying the problems, causes, the activities affected and describing the means and methods available to complete the Project by the Contract Time.

4. Final Completion: When CONTRACTOR believes that all elements of its work on the Project, including all of the requirements of the Contract, have been completed, it shall notify SCDOT in writing. Final Completion shall be achieved within 180 calendar days of Substantial Work Completion as defined in this Agreement. Within thirty (30) days thereafter, SCDOT will acknowledge project completion or will advise CONTRACTOR in writing of any aspect of the Contract or the Project Scope that is incomplete or unsatisfactory. CONTRACTOR shall complete all corrective action within thirty (30) days after written notification of incomplete or unsatisfactory items. CONTRACTOR will notify SCDOT in writing upon completion of necessary corrective action. SCDOT will verify satisfactory completion of the corrective action in writing to CONTRACTOR. Upon verification, the Project shall be deemed to have achieved Final Completion.
5. Inspection/Acceptance; No Waiver: No inspection, acceptance, payment, partial waiver, or any other action on the part of SCDOT will operate as a waiver of any portion of this Agreement or of any power reserved herein or any right to damages or other relief, including any warranty rights, except insofar as expressly waived by SCDOT in writing. SCDOT will not be precluded or estopped by anything contained herein from recovering from CONTRACTOR any overpayment as may be made to CONTRACTOR.

#### **B. Contract Time Adjustments**

The Contract Time may be extended if there is a delay to the critical path of the Project caused by an event listed below. All requests for time extensions shall be made in writing to SCDOT within 20 days of the event causing the delay. All time extensions must be approved in writing by SCDOT. Time extensions may be allowed for the following events that affect the critical path:

1. Force Majeure as that term is defined in this Agreement in Article XIV;
2. Changes or construction change directives;
3. Differing site conditions as defined under Article XIII;
4. Injunctions, lawsuits, or other efforts by individuals or groups that hinder, delay, or halt the progress of the Project, provided that such efforts are not premised on alleged wrongs or violations by CONTRACTOR or its subcontractors;
5. Interference with or delay of work on the critical path of the Project by SCDOT; however, CONTRACTOR shall not be entitled to a time extension if SCDOT's

actions are necessitated by CONTRACTOR's actions, omissions, failure to perform quality work, or failure to comply with contract requirements;

6. Changes in the legal requirements or regulations which are effective subsequent to the date of this Agreement;
7. Discovery of hazardous materials not previously identified as set forth in Article XI;
8. Discovery of archeological or paleontological remains not previously identified as set forth in Article X; or
9. Adverse utility relocation impacts meeting the requirements set forth in Article VII.

### **C. Owner's Right to Stop Work**

SCDOT will have the authority to suspend the work, wholly or in part, for such periods, as SCDOT may deem necessary, due to CONTRACTOR's failure to meet the requirements of the Contract in the performance of the work. Such suspension of the work shall not constitute grounds for claims for damages, time extensions, or extra compensation.

### **D. Liquidated Damages**

CONTRACTOR shall pay liquidated damages to SCDOT in the amount of Ten Thousand Dollars (\$10,000.00) for each day for which construction is not substantially complete, as defined in Article IV.

CONTRACTOR shall pay liquidated damages to SCDOT in the amount of One Thousand Five Hundred Dollars (\$1,500.00) for each day that Final Completion, as defined in Article IV, is not achieved.

The parties acknowledge, recognize and agree that because of the unique nature of the Project, it is difficult or impossible to determine with precision the amount of damages that would or might be incurred by SCDOT as a result of the CONTRACTOR's failure to complete the Project as specified in the Contract. Therefore, any sums payable under this provision are in the nature of liquidated damages, and not a penalty, and are fair and reasonable and such payment represent a reasonable estimate of fair compensation for the losses that may reasonably be anticipated from such failure. Notwithstanding the above, liquidated damages are not intended to excuse the CONTRACTOR from liability for any other breach of its obligations under the Contract.

## **V. QUALITY ASSURANCE PROGRAM**

### **A. CONTRACTOR's Responsibilities**

CONTRACTOR shall be responsible for the QUALITY CONTROL Portion of the Program to include the items listed below. Work shall not commence until CONTRACTOR has met these requirements.

1. Quality Control Plan: CONTRACTOR shall submit a Quality Control (QC) Plan that outlines how CONTRACTOR shall assure that the materials and work are in compliance with the contract documents. The initial plan shall be submitted to SCDOT for review and approval at least five (5) business days prior to any design or plan submittal or the beginning of any construction activity. The plan shall be updated as necessary prior to the start of any specific construction operation. The plan shall include a list of SCDOT certified personnel responsible for management and quality control of the Project, and define the authority of each individual. The plan shall also include how CONTRACTOR will monitor quality and deal with failing materials. The QC Plan shall include the QC testing and sampling frequencies and shall indicate the frequency at which the QC Manager will provide QC test results to SCDOT. CONTRACTOR shall provide a summary of estimated quantities to SCDOT for the purposes of meeting the minimum sampling and testing requirements in accordance with the SCDOT Construction Manual. The summary of estimated quantities shall be included in the QC Plan.
2. Personnel: CONTRACTOR shall provide a sufficient number of SCDOT certified personnel to adequately control the work of the Project. Any personnel required to obtain samples or conduct material testing shall be SCDOT certified. CONTRACTOR shall provide SCDOT with copies of each individual's certifications for review and approval by SCDOT. Approved CONTRACTOR QC personnel shall be on the job at all times that permanent work items and materials are being incorporated into the project. CONTRACTOR's QC personnel shall not have any other project responsibilities.
3. CONTRACTOR Testing: CONTRACTOR is required to conduct asphalt sampling and testing in accordance with the SCDOT Standard Specifications and the SCDOT Supplemental Technical Specifications SC-M-400. CONTRACTOR shall conduct sampling and testing to ensure that all workmanship and materials are in compliance with the contract requirements. Although not used for acceptance, QC testing and inspection shall ensure that quality has been incorporated into all elements of work prior to requesting acceptance testing and inspection. The QC Program should be sufficient in scope to remedy repeated discoveries of non-compliant work by those performing acceptance inspection and testing. Repeated observations of QC quality shortfalls shall be considered a breakdown of the QC program and shall be cause for investigation and corrective action prior to commencement of work areas affected. Corrective action may include the addition of new QC procedures, revision to existing QC procedures, re-training of QC personnel, removal and replacement of QC personnel, or other such actions which will restore the effectiveness of the QC program. All QC testing shall be performed in accordance with existing AASHTO, ASTM, or test methods used by SCDOT. The cost of these activities will be borne by

CONTRACTOR. Additionally, CONTRACTOR is responsible for dynamic and static load testing of drilled shafts and piles in accordance with the requirements of **EXHIBITS 4 and 5**.

4. Testing Laboratories: All testing laboratories used on the Project must be AASHTO certified and approved by SCDOT thirty (30) days prior to beginning the portion of work for which the laboratory will be performing the testing. Hot Mix Asphalt testing laboratories require SCDOT certification.
5. Mix Designs: Copies of all initial hot-mix asphalt mix designs and Portland Cement Concrete mix designs, along with supporting data, shall be submitted to SCDOT for review at least five (5) business days prior to use. All hot-mix asphalt mix designs will be prepared by personnel certified in Mix Design Methods. Portland Cement Concrete mix designs will be prepared by a certified concrete technician or a Professional Engineer. The Portland Cement Concrete mix proportions given in the specifications are to be followed. CONTRACTOR shall design the mix to obtain the strength and water/cement ratios given in the specifications, and shall provide workability, air content, gradation and suitable set times as set forth in the Standard Specifications. The SCDOT will be notified of any revisions to CONTRACTOR's mix design. Copies of such revisions will be sent to SCDOT for review at least ten (10) business days prior to use.
6. Materials Certifications: CONTRACTOR's QC Manager shall submit all material certifications to SCDOT prior to the CONTRACTOR incorporating the material into the project.

## **B. SCDOT Responsibilities**

SCDOT will be responsible for the QUALITY ACCEPTANCE portion of the program to include: conducting inspections, acceptance testing, independent assurance testing and final project material certification.

1. Acceptance Testing: SCDOT personnel assigned to the Project, or qualified personnel retained by SCDOT, will conduct sampling and testing, separate from CONTRACTOR's testing, at the frequencies set forth in SCDOT's construction manual. This testing will be used by SCDOT to determine the acceptability of the materials. All sampling and testing will be in accordance with existing AASHTO, ASTM, or SC test methods used by SCDOT. The cost of these activities will be borne by SCDOT. CONTRACTOR's QC Manager is required to coordinate all activities closely with SCDOT to allow the necessary acceptance testing to be conducted prior to proceeding to the next operation. The disposition of failing materials must be approved by SCDOT.
2. Independent Assurance Testing: SCDOT will be responsible for conducting Independent Assurance Testing. Personnel performing these tests will be SCDOT employees or qualified persons retained by SCDOT. Persons performing these tests will not be involved in Acceptance Testing. This testing will be used to ensure that proper sampling and testing procedures are being followed, and that

testing equipment is functioning properly. This testing will consist of observing sampling and testing by both SCDOT personnel performing Acceptance Testing and CONTRACTOR personnel performing Quality Control Testing, as well as taking split samples for the purposes of comparison testing. Independent Assurance Testing will be at an approximate frequency of one-tenth of the Acceptance Testing frequency. Independent Assurance test results will not be used for acceptance. The cost of these activities will be borne by SCDOT.

3. Materials Certification: SCDOT will be responsible for preparing the Materials Certification as required by the FHWA on federally funded projects.

### **C. CONTRACTOR's Obligation**

SCDOT's testing in no way relieves CONTRACTOR of its obligation to comply with the Contract requirements. All materials incorporated into the Project must meet or exceed contract requirements and specifications. Further, any testing by SCDOT will not relieve CONTRACTOR of any of its warranty obligations.

## **VI. INSURANCE AND BONDING**

### **A. Insurance**

1. CONTRACTOR shall purchase and maintain insurance using a company or companies that maintain an A.M. Best rating of not less than A-VII with coverage forms acceptable to SCDOT. The insurance described below shall be maintained uninterrupted for the duration of the Project, including warranty periods, and shall protect CONTRACTOR from claims set forth below which may arise out of or result from CONTRACTOR's operations under the Contract, whether such operations be performed by CONTRACTOR or by any subcontractor or by anyone directly or indirectly employed by any of them or by anyone for whose acts any of them may be liable:
  - a. Claims under workers' or workmen's compensation, disability benefit and other similar employee benefit acts;
  - b. Claims for damages because of bodily injury, occupational sickness or disease, or death of CONTRACTOR's employees;
  - c. Claims for damages because of bodily injury, sickness or disease, or death of any person other than CONTRACTOR's employees;
  - d. Claims for damages insured by usual personal injury liability coverage which are sustained (1) by any person as a result of an offense directly or indirectly related to the employment of such person by CONTRACTOR, or (2) by any other person;
  - e. Claims for damages, other than to the work itself, because of injury to or destruction of tangible property, including loss of use resulting therefrom;

- f. Claims for damages because of bodily injury or death of any person or property damage arising out of the ownership, maintenance or use of any motor vehicle.
  - g. Claims involving contractual liability insurance applicable to the Contractor's obligations under the indemnity provisions of this contract.
2. The minimum limits of liability for the following types of insurance are required, except where greater limits are required by statute:

- a. Workers' Compensation, including: Worker's Compensation Insurance/Employer's Liability

State Statutory limits	Employer's Liability
	\$100,000 per accident
	\$500,000 per disease
	\$100,000 each employee

- b. Commercial General Liability
- |  |                              |
|--|------------------------------|
|  | \$2,000,000 per occurrence   |
|  | \$4,000,000 annual aggregate |

Commercial General Liability insurance shall be written on ISO occurrence form CG 00 01 (or substitute for providing equivalent coverage) and shall cover liability arising from premises, operations, independent contractors, products-completed operations, contractual liability and personal injury and advertising injury. The policy shall contain the per project endorsement.

- c. Business Automobile Liability
- |  |                            |
|--|----------------------------|
|  | \$1,000,000 per occurrence |
|--|----------------------------|

This policy shall cover Any Auto, including Owned, Hired and Non-owned Automobiles. Business auto coverage shall be written on ISO form CA 00 01, CA 00 05, CA 00 12, CA 00 20, or a substitute form providing equivalent liability coverage.

- d. Umbrella Liability Coverage
- |  |                               |
|--|-------------------------------|
|  | \$25,000,000 per occurrence   |
|  | \$25,000,000 annual aggregate |

The general aggregate limit shall apply separately to the Project

3. Certificates of Insurance acceptable to SCDOT will be provided to SCDOT prior to execution of this Agreement. These certificates shall name SCDOT as an additional insured under the Commercial General Liability (CGL) arising out of both the on-going operations and completed operations of CONTRACTOR. Such additional insured coverage shall be endorsed to Contractor's CGL policy using ISO Additional Insured Endorsement form CG 2010 (10/01) and CG 2037 (10/01) or a substitute providing equivalent coverage, and included under the commercial umbrella. CONTRACTOR shall maintain continual additional insured status for SCDOT under the products-completed operations coverage for the time period required to satisfy the statute of limitation for South Carolina. CONTRACTOR

shall also name SCDOT as additional insured under Business Automobile and Umbrella policies and reference the Project to which the certificate applies. The policies must contain a provision that coverage afforded will not be canceled or reduced until at least 30 days prior written notice has been given to SCDOT and that the policies cannot be cancelled for non-payment of premiums until at least 10 days prior written notice has been provided to SCDOT. Send Notice of Cancellations to Director of Construction Room 330, PO Box 191, Columbia, SC 29202. Make certain that the policies are endorsed to reflect this requirement. Verification of additional insured status shall be furnished to SCDOT by including a copy of the endorsements with the Certificate of Insurance. This insurance, including insurance provided under the commercial umbrella shall apply as primary and noncontributory insurance with respect to any other insurance or self-insurance programs, including any deductibles, afforded to, or maintained by, SCDOT. CONTRACTOR'S deductibles shall not exceed \$1,000,000 without written consent of the SCDOT and that the certificates show the deductible amounts. CONTRACTOR shall provide evidence of financial ability to cover the amount of the deductible at the time of the execution of the agreement and for every year thereafter until the insurance obligation ends.

4. Limits shown in this provision are minimum acceptable limits and in no way limit available coverage to the additional insured. CONTRACTOR's CGL and commercial umbrella policies shall contain no provision providing that the limits available to an additional insured are less than the limits available to the CONTRACTOR. SCDOT shall be given all the same rights and insurance coverage as CONTRACTOR. In the event that any insurer issues a reservation of rights for SCDOT as an additional insured, SCDOT shall be entitled to employ independent counsel, of its choice, at CONTRACTOR's expense.
5. There shall be no endorsements or modifications of the CGL limiting the scope of coverage for liability arising from explosion, collapse, underground property damage or work performed by contractors on behalf of SCDOT.
6. Hazardous Materials: If the CONTRACTOR is required to remove and haul any hazardous waste from the Project, or if the Project involves such similar environmental exposure, pollution liability coverage equivalent to that provided under the ISO Pollution Liability – Broadened Coverage for Covered Autos Endorsement (CA 99 48), shall be provided, and the Motor Carrier Act Endorsement (MCS 90) shall be attached. Limits of pollution liability shall be not less than \$1,000,000 per occurrence. Coverage shall apply on an “occurrence form” basis, shall cover at a minimum bodily injury, property damage, defense costs and clean-up costs and be extended to include non-owned disposal sites and transportation coverage. This insurance shall remain in effect after acceptance by Owner for the time period required to satisfy the statute of limitations in South Carolina. However, if coverage is written on a “claims made form”, then the Contractor's Pollution Liability coverage shall include a retroactive date that precedes the commencement of work under this Agreement. Such coverage shall apply as primary and non-contributory insurance with respect to any other



insurance or self-insurance programs, including any deductibles, afforded to, or maintained by SCDOT.

7. Waiver of Subrogation: CONTRACTOR shall waive its rights against SCDOT, other additional insured parties, and their respective agents, officers, directors and employees for recovery of damages, or any other claims, to the extent these damages are covered by the CGL, business auto, pollution liability, workers compensation and employer's liability or commercial umbrella maintained pursuant to this section of the Agreement.
8. CONTRACTOR shall at the time of execution of this Agreement, obtain Errors and Omissions insurance for their Professional Liability, for all claims arising from the performance of professional services on the Project. The insurance coverage shall be for not less than Five Million Dollars (\$5,000,000) per claim and in the aggregate. The coverage shall be continued for three (3) years after the date of Final Completion of the Project. Evidence of such insurance shall be provided to SCDOT at the time of the execution of the Agreement. CONTRACTOR shall also show at the time of execution of the Agreement evidence that all other designers on the project have obtained Professional Liability Insurance of sufficient coverage to protect from claims arising from their design services.
9. CONTRACTOR shall provide "Builders Risk Insurance" acceptable to the SCDOT in the amount of the Contract Price protecting the respective interests of SCDOT and CONTRACTOR and covering physical loss or damage to the work during construction of the Project. The certificate of insurance shall be provided to the SCDOT at the time of execution of this Agreement. The CONTRACTOR shall also obtain \$5,000,000.00 in Delay in Start Up Coverage under the Builder's Risk policy. The policy shall name the SCDOT as an additional insured and shall reference the Project by name. The certificate shall also state that the coverage will not be cancelled or reduced without 30 days prior written notice to the SCDOT.
10. After Final Completion of the work, CONTRACTOR shall maintain CGL and commercial umbrella coverage to include liability coverage for damage to insured's completed work equivalent to that provided under ISO CG 00 01 for three (3) years or for the statute of limitations period for damages, whichever is greater.
11. By execution of the contract, the CONTRACTOR accepts the responsibility to provide the liability insurance policies and endorsements as specified herein. Failure of SCDOT to identify a deficiency in the Certificate of Insurance submitted by the CONTRACTOR's insurance agent as evidence of the specified insurance or to request other evidence of full compliance with the liability insurance specified shall not be construed as a waiver of the CONTRACTOR's obligation to provide and maintain the required insurance for the duration of the contract.

## **B. Bonding**

1. CONTRACTOR shall at the time of the execution of this Agreement, provide SCDOT the following bonds:
  - a. A Performance and Indemnity Bond from a surety or sureties satisfactory to SCDOT. The amount of bond shall be equal to the Contract Price.
  - b. A Payment Bond from a surety or sureties satisfactory to SCDOT. The amount of bond shall be equal to the Contract Price.

These bonds shall be in accordance with the requirements of S.C. Code Ann. §57-5-1660, (1976 as amended) and S.C. Code Ann. §29-6-250 (2000). Bonds shall be issued by a surety company licensed in the State of South Carolina with an “A” minimum rating of performance as stated in the most current publication of “A.M. Best Key Rating Guide, Property Liability” and signed by the surety's agency or attorney-in-fact. Surety must be listed on the current U.S. Department of the Treasury Financial Management Service list of approved bonding companies as approved for an amount equal to or greater than the amount for which it obligates itself in the Bond. If surety qualifies by virtue of its Best's listing, the amount of the Bond may not exceed ten percent of policyholders' surplus as shown in the latest A.M. Best's Key Rating Guide.

2. CONTRACTOR shall also provide a warranty bond, acceptable to SCDOT, in the amount of Five Million Dollars (\$5,000,000) to cover the warranty obligations of the contract.

## **VII. UTILITIES AND RAILROAD COORDINATION**

- A.** As part of the Project Scope, CONTRACTOR shall have the responsibility of coordinating the Project construction and demolition activities with all utilities that may be affected. CONTRACTOR shall be responsible for the cost of utility coordination as defined herein. If applicable, all temporary relocation costs as well as any other conflict avoidance measures shall be the responsibility of the CONTRACTOR. For those utilities that have prior rights SCDOT will be responsible for permanent relocation costs as defined by the Federal code. For those utilities where the CONTRACTOR determines that the SCDOT has prior rights, CONTRACTOR may exercise these rights and require the utility company to bear the costs of relocation. If there is a dispute over prior rights, SCDOT shall be responsible for resolving the dispute. SCDOT shall have final determination of the utility's prior rights.
- B.** For those utilities requiring relocation, CONTRACTOR shall conform with SCDOT's “A Policy for Accommodating Utilities on Highway Rights of Way”, the applicable State laws, and the Code of Federal Regulations, Title 23, Chapter 1, Subchapter G, part 645, subparts A and B.
- C.** The resolution of any conflicts between utility companies and the construction of the Project shall be the responsibility of the CONTRACTOR. If said utility companies

interfere or fail to relocate conflicting utilities in a timely manner, SCDOT may, on an individual basis, consider a time extension for utility company delays when CONTRACTOR can demonstrate that appropriate coordination efforts have been made to expedite the utility relocation, and that the delay has a direct impact on the approved Critical Path. CONTRACTOR shall not be entitled to additional compensation for interference or delays in utility relocations. CONTRACTOR shall meet with the Department's Utilities Office within thirty (30) days of the Notice to Proceed to gain a full understanding of what is required with each utility submittal.

- D. CONTRACTOR shall design the Project to avoid conflicts with utilities where possible, and minimize impacts where conflicts cannot be avoided. If there is a dispute between the CONTRACTOR and SCDOT as to whether a utility relocation is required, SCDOT shall have the final determination. Additional utility relocations desired by the CONTRACTOR for but not limited to construction staging, access or convenience, shall be the sole responsibility of CONTRACTOR and all associated costs shall be borne by the CONTRACTOR.
- E. CONTRACTOR shall initiate early coordination with all utilities and provide the utility companies with design plans for their use in developing Relocation Sketches as soon as the plans have reached a level of completeness adequate to allow the companies to fully understand the Project impacts. If a party other than the utility company prepares Relocation Sketches, there shall be a concurrence box on the plans where the utility company signs and accepts the Relocation Sketches as shown.
- F. CONTRACTOR shall be responsible for collecting and submitting to SCDOT the following from each utility company that is located within the project limits:
  - 1. **Relocation Sketches** including letter of "no cost" where the company does not have a prior right;
  - 2. **Utility Agreements** including documentation of prior rights, cost estimate and relocation plans where the company has a prior right; and/or
  - 3. **Letters of "no conflict"** where the company's facilities will not be impacted by the Project. Include location sketches on SCDOT plans confirming and certifying that facilities are not in conflict.
  - 4. **Encroachment Permits** for all relocations regardless of prior rights.
- G. CONTRACTOR shall assemble the information included in the Utility Agreements and Relocation Sketches in a final and complete form and in such a manner that the Department may approve the submittals with minimal review. CONTRACTOR shall ensure that there are no conflicts with the proposed highway improvements, or between each of the utility company's relocation plans. CONTRACTOR may not authorize the utility companies to begin their relocation work until authorized in writing by SCDOT. Any early authorization by CONTRACTOR shall be at the CONTRACTOR's risk.
- H. At the time that CONTRACTOR notifies SCDOT that CONTRACTOR deems the Project to have reached Final Completion, CONTRACTOR shall certify to SCDOT

that all utilities have been identified and that those utilities with prior rights or other claims related to relocation or coordination with the Project have been relocated or their claims otherwise satisfied or will be satisfied by CONTRACTOR.

- I. CONTRACTOR shall accurately show the final location of all utilities on the as-built drawings for the Project. SCDOT reserves the right to request CADD files as needed.

**If Railroad property is impacted by this project, provisions J through S shall apply:**

- J. Under the direction of and in coordination with SCDOT, the CONTRACTOR shall be responsible for all coordination with the involved Railroad Companies, including but not limited to, sending plans, meetings, correspondence, phone calls, writing/reviewing agreements, and etc. as may be necessary to secure the applicable executed railroad agreements, needed for the construction of the project, between the SCDOT and all involved railroad companies. All correspondence related to railroad agreements or conditions shall include the railroad file number and railroad milepost information. The CONTRACTOR shall be responsible for the cost of railroad coordination as defined herein.
- K. SCDOT will submit for approval, all required railroad agreements necessary for the Preliminary Engineering and Construction of the project. Upon approval, the SCDOT will submit the agreement to the Railroad Company for execution. The CONTRACTOR shall be responsible for assisting SCDOT in the development of the railroad agreement by providing requested information.
- L. The CONTRACTOR shall be responsible for all costs to the Railroad Company or Companies for services provided by the Railroad or the Railroad's Agent, as detailed in the executed Railroad Agreement between the SCDOT and the Railroad. This includes all expenses such as railroad flagging operations. The CONTRACTOR shall be responsible for all other costs associated with designing and constructing the project as described in the executed Railroad Agreement between the SCDOT and the Railroad Company. The CONTRACTOR shall include all costs associated with these requirements in the final bid price. Once a contract is executed, SCDOT shall administer invoicing for costs to the Railroad Company or Companies. Monies will be deducted from the CONTRACTOR's progress payments.
- M. All design and construction activities in, adjacent to, over or under the railroad shall comply with all applicable Federal and State laws and standards, all terms identified in the Special Provisions for Protection of Railway Interests, and all terms of the final agreement executed with the Railroad Company.
- N. The CONTRACTOR shall be required to meet the Railroad's Insurance Requirements as specified in the Special Provisions for Protection of Railway Interests.
- O. The CONTRACTOR shall attend a mandatory meeting with the SCDOT's Utilities Office and Railroad Projects Office within thirty (30) days after the Notice to Proceed. The CONTRACTOR shall use the SCDOT approved agreement language and procedures, that will be provided in this meeting.

- P.** CONTRACTOR shall provide project specific information to SCDOT for inclusion into the agreements. The CONTRACTOR shall anticipate and include in the proposed schedule a minimum 90-day approval time-frame for all railroad agreements. However, SCDOT will not be held responsible for delays caused by negotiations with the railroad company.
- Q.** CONTRACTOR shall anticipate the need for a separate right-of-entry agreement between the CONTRACTOR and Railroad for surveys, borings, etc. The required PE Agreement, between SCDOT and Railroad, must be executed before Railroad will review or comment on any design questions or submittals from the CONTRACTOR. The Construction Agreement, between SCDOT and Railroad, must be executed before any construction activities can begin.
- R.** CONTRACTOR is advised that all utility relocations required within railroad right-of-way will require separate agreements between the affected utility company and the Railroad.

## **VIII. RIGHT OF WAY ACQUISITION**

### **A. Right of Way Services**

CONTRACTOR is not responsible for acquiring right of way shown as “PRESENT R/W” or “NEW R/W” on the Conceptual Roadway Plans included in Attachment C. If necessary for CONTRACTOR’s plan, CONTRACTOR shall acquire all rights of way outside of the above stated limits. Prior to starting construction activities, the CONTRACTOR shall prepare and obtain SCDOT approval of right-of-way certification(s).

CONTRACTOR, acting as an agent on behalf of the State of South Carolina, shall provide right-of-way services for the Project. CONTRACTOR shall use firm(s) from the SCDOT’s current “on-call” list for right of way consultants, to provide right of way services. Right-of-way services shall include appraisal, appraisal review, negotiation, acquisition, and relocation assistance services. CONTRACTOR shall be responsible for all costs related to these right-of-way services. CONTRACTOR shall provide expert testimony and SCDOT will provide legal services necessary for any cases that are to be resolved by trial. Experts are defined as engineering and appraisal witnesses. SCDOT will retain final authority for approving just compensation, relocation benefits and settlements. SCDOT will designate a hearing officer to hear any Relocation Assistance Appeals. SCDOT agrees to assist with any out of state relocation by persons displaced within the rights of way by arranging with such other state(s) for verification of the relocation assistance claim. CONTRACTOR shall carry out the responsibilities as follows:

1. Acquire property in accordance with all Federal and State laws, guidelines, and regulations, including but not limited to the Uniform Relocation and Real Property Acquisition Act of 1970, as amended (the “Uniform Act”), the SCDOT Acquisition Manual, the SCDOT Appraisal Manual, SCDOT Relocation Manual, and the South Carolina Eminent Domain Procedure Act (“The Act”).

CONTRACTOR shall not be entitled to an increase in the Contract Price for acquisition of borrow sources.

2. Submit procedures for handling right-of-way acquisitions and relocations to the SCDOT for approval prior to commencing right-of-way activities. These procedures are to show CONTRACTOR'S method including the appropriate steps and workflow required for appraisal, acquisition, and relocation. CONTRACTOR shall be granted the authority for administrative settlements by the SCDOT's Right-of-Way Office upon review and approval of the Right-of-Way Procedures. These procedures should also include an appropriate time allowance for SCDOT to establish just compensation, approve relocation benefits, and approve administration and legal settlements. A SCDOT Representative will be available to make timely decisions concerning establishing just compensation, approving relocation benefits, and approving administrative settlements on behalf of SCDOT. The SCDOT Representative is committed to issuing decisions on approval requests within three (3) business days. The commitment is based on the procedure providing a reasonable and orderly workflow and the work being provided to the SCDOT Representative as completed.
3. Utilize SCDOT's right-of-way project tracking system and provide an electronic status update a minimum of twice per month or upon request by SCDOT's representative.
4. As part of the right-of-way acquisitions and relocation procedures, include a right-of-way quality control plan to the SCDOT for review prior to commencing right-of-way activities. SCDOT standard forms and documents will be used to the extent possible.
5. Provide a toll free telephone number for landowners and displaced persons to call and an office near the Project which is located within the State of South Carolina for the duration of the right of way acquisition and relocation services for this Project.
6. Provide a current title certificate by a licensed South Carolina attorney for each parcel within ninety (90) days of the date of closing or the date of filing of the Condemnation Notice.
7. Prepare appraisals in accordance with the Department's Appraisal Manual. Appraisals shall be prepared by appraisers who are on the SCDOT approved list of active fee appraisers.
8. Provide appraisal reviews complying with technical review guidelines of SCDOT Appraisal Manual and make a recommendation of just compensation. The reviewer shall be from the SCDOT's approved reviewer list.

9. Make direct payments of benefits to property owners for negotiated settlements, relocation benefits and payments to be deposited with the court and notify SCDOT monthly of payments made.
10. Prepare, obtain execution of, and record documents conveying title to such properties to SCDOT with Register of Deeds, and deliver all executed and recorded general warranty deeds to SCDOT. For all property in conjunction with the Project, title will be acquired in fee simple (except that SCDOT may in its sole discretion direct the acquisition of a right-of-way easement or permissions, in lieu of fee simple title, with respect to any portion of the Rights of Way) and shall be conveyed to “The South Carolina Department of Transportation” by general warranty deed, free and clear of all liens and encumbrances except permitted encumbrances.
11. Because these acquisitions are being made as agent on behalf of the State of South Carolina, SCDOT shall make the ultimate determination in each case as to whether settlement is appropriate or whether the filing of a condemnation action is necessary, taking into consideration the recommendations of the CONTRACTOR. When SCDOT authorizes the filing of a condemnation, CONTRACTOR shall prepare a Notice of Condemnation in the name of SCDOT, and submit it to SCDOT for SCDOT to file and serve appropriate condemnation documents and pleadings, and request priority status pursuant to S.C. Code Ann. Section 28-2-310(1976, as amended).
12. SCDOT shall prosecute condemnation proceedings to final judgment pursuant to the requirements of the South Carolina Eminent Domain Procedures Act. The procedure shall be by way of trial as provided by Section 28-2-240 of “The Act”. SCDOT shall be responsible for obtaining legal representation and CONTRACTOR will be responsible for providing expert witnesses, necessary for condemnation actions. All settlements of condemnation cases shall be at SCDOT’s sole discretion.
13. CONTRACTOR will be responsible for all contacts with landowners for rights-of-way or construction items and shall provide the following:
  - a. All Notices of Condemnation, issued pursuant to the authority granted, all titles of real estate and all right of way easements, recorded with the Office of the Register of Deeds or the Clerk of Court for the county or counties in which properties acquired through condemnation are located;
  - b. All drainage permissions, slope permissions, Right of Entry agreements, and releases;
  - c. A right-of-way agent’s worksheet, or documents substantially in the format of SCDOT Form No. 809, for each tract.

14. CONTRACTOR shall provide a right-of-way certification and SCDOT shall approve that certification prior to CONTRACTOR entering the property. Only in exceptional circumstances will a certification be approved based on a right of entry. Certification may be on a tract-by-tract basis.
15. If after right of entry Certifications have been submitted there remains outstanding remaining tracts that have not been resolved, CONTRACTOR shall exercise care in its operations when working in proximity to adjacent developed properties, properties not yet acquired, and residences or businesses that are to be relocated. CONTRACTOR shall submit a plan to the SCDOT's right-of-way representative for approval to:
  - a. Establish a clear zone adjacent to properties occupied by persons to be displaced in which construction equipment may not be operated or parked,
  - b. Establish a clear zone for construction for properties occupied by persons to be displaced to prevent undue impacts or hardships,
  - c. Establish a method of protecting equipment from vandalism or unauthorized use,
  - d. Perform all burning in accordance with applicable laws and ordinances, with specific attention to SCDHEC's Bureau of Air Quality Control criteria which require compliance with the South Carolina Air Pollution Control laws, regulations, and standards as they concern the related work included in the Contract.
  - e. Provide reasonable and safe access to residences or businesses that are to be displaced until such time as the property is vacant, and
  - f. Observe the property rights of landowners of adjacent and/or yet to be acquired properties.
16. CONTRACTOR shall use reasonable care in determining whether there is reason to believe that property to be acquired for rights-of-way may contain concealed or hidden wastes or other materials or hazards requiring remedial action or treatment. When there is reason to believe that such materials may be present, CONTRACTOR shall take steps consistent with customary industry standards to investigate. SCDOT shall be notified of the presence of such materials before an offer is made to acquire the property.
17. During the acquisition process and for a period of three years after final payment is made to CONTRACTOR for any phase of the work, all project documents and records not previously delivered to SCDOT, including but not limited to design and engineering costs, construction costs, costs of acquisition of rights-of-way, and all documents and records necessary to determine compliance with the laws relating to the acquisition of rights-of-way and the costs of relocation of utilities, shall be maintained and made available to SCDOT for inspection or audit.



## **B. Acquisition of Right-of-Way**

1. The CONTRACTOR is responsible for verification of all information necessary for acquisition of the Right-of-Way (ROW) and is responsible for all costs, excluding premium cost as defined below, associated with the purchase of the Right-of-Way. The CONTRACTOR shall acquire the property as an agent on behalf of the State of South Carolina.
2. Acquisition of any additional area (not right of way) desired by the CONTRACTOR for, but not limited to, construction staging, access or borrow pits, shall be the sole responsibility of CONTRACTOR, and any title or interest shall be secured in the name of the CONTRACTOR. CONTRACTOR shall provide SCDOT the location and documentation for these additional areas. CONTRACTOR shall furnish SCDOT a copy of any agreements, whether for purchase or lease, for the use of additional properties in conjunction with the construction of the Project. CONTRACTOR shall abide by the provisions of all applicable environmental permits, any conditions of individual right of way agreements, and all environmental commitments. Any necessary permit modifications are the responsibility of the CONTRACTOR. CONTRACTOR is responsible for all costs associated with these additional areas, including premium right-of-way costs. If additional right-of-way is necessary beyond what has been evaluated in the NEPA documentation, CONTRACTOR shall be responsible for any re-evaluation of the approved Environmental Documents.
3. ROW acquisition costs shall be defined as amounts paid for: (1) direct payments for ownership or other property rights, and (2) direct payments for eligible relocation expenses as provided for under the Uniform Act less Premium ROW acquisition costs.
4. Premium ROW acquisition costs shall be the amount a jury award or a settlement that exceeds "Just compensation." "Just compensation" shall be defined as the value SCDOT approves for a parcel after the following procedure: CONTRACTOR shall submit its recommendation for just compensation based on appraisals and appraisal reviews which support the recommendation. If SCDOT approves CONTRACTOR'S recommendations, that value becomes just compensation. If SCDOT does not approve the recommendation, CONTRACTOR or SCDOT shall obtain another appraisal using an appraiser from the SCDOT's approved list and submit this appraisal to SCDOT. SCDOT shall be responsible for the cost of the second appraisal. SCDOT shall assign a value to the parcel which shall be deemed just compensation supported by the appraisals for the parcel.
5. CONTRACTOR shall be responsible for right-of-way service costs and right-of-way acquisition costs.
6. SCDOT shall be responsible for premium right-of-way costs except for those additional areas explained above.

7. Upon final completion of the project, if any right-of-way condemnation actions are still pending, CONTRACTOR shall be responsible for adequate security to cover its contractual obligation relating to right-of-way acquisition.

## **IX. PERMITS**

- A. The following permits have been acquired and are available in Attachment B:
  1. USACE Section 404 Permit (SAC-2015-0476-SIR)
  2. SCDHEC-OCRM Section 401 Coastal Zone Consistency Certification (SAC-2015-0476-SIR)
- B. All permits necessary for completion of this project shall be procured by the CONTRACTOR. The CONTRACTOR shall comply with all local, state, and federal permitting requirements. Regarding any permit or license that must be obtained in the name of SCDOT, the CONTRACTOR shall perform all functions within its power to obtain the permit or license, and SCDOT shall fully cooperate in this effort and perform any functions that must be performed by SCDOT. The CONTRACTOR shall submit permit applications to SCDOT. SCDOT will submit the permit application to the appropriate permitting agency indicating that CONTRACTOR is acting as an agent for SCDOT. If said regulatory agencies fail to issue permits in a timely manner, SCDOT may, on an individual basis, consider a time extension for permit approval delays when CONTRACTOR can demonstrate that the application was submitted in a timely manner, all reasonable efforts have been made to expedite the permit approval, and that the delay has a direct impact on the Critical Path. CONTRACTOR shall not be entitled to additional compensation for delays in permit approval.

## **X. ENVIRONMENTAL COMPLIANCE**

### **A. Compliance with Environmental Commitments**

CONTRACTOR shall comply with all Environmental commitments and requirements including, but not limited to, the following:

1. Compliance with the provisions of all environmental permits applicable to the Project. A copy of the environmental document is included in **Attachment B**. Environmental Commitments are included in **Exhibit 4**.
2. Compliance with those stipulations and conditions under which SCDOT or Permittee received approval of the Environmental Document(s) and any modifications resulting from a re-evaluation of the Document(s). If the CONTRACTOR elects to construct the Project in a manner that is not consistent with the assumptions in the project related environmental documents, the CONTRACTOR shall be responsible for revising the environmental documents and providing any additional studies that may be required. All revisions will require SCDOT and FHWA approval prior to any right of way acquisition or construction activity;

3. Compliance with applicable laws and regulations relating to potential or actual hazardous materials that may be encountered in the course of carrying out this Agreement;
4. Carrying out all necessary social, economic, and environmental studies required by regulatory authorities in the course of construction;
5. Cost, preparation, revision, acquisition, compliance, and adherence to conditions of any permits required by federal, state, or local laws or regulations; The CONTRACTOR is responsible for any mitigation required by any revisions to permits; and
6. The resolution of any deviations from the contract documents, drawings or other information included in the environmental permits that would violate the intent or spirit of the permits. Any proposed changes within the permitted areas would need to be coordinated with SCDOT's Environmental Services Office.

**B. Preconstruction / Partnering Conference(s)**

CONTRACTOR shall conduct one (or more, if appropriate) pre-construction / partnering conference(s) prior to any construction activity to discuss environmental and permitting issues, which conference shall include, but not be limited to, all subcontractors and, to the extent feasible, representatives from the USACE, SCDHEC Water Quality Division, FHWA, CONTRACTOR, and SCDOT.

**C. Protection of Archeological and Paleontological Remains and Materials**

1. When archeological or paleontological remains are uncovered, CONTRACTOR shall immediately halt operations in the area of the discovery and notify SCDOT.
2. Archeological remains consist of any materials made or altered by man which remains from past historic or prehistoric times (i.e. older than 50 years) Examples include old pottery fragments, metal, wood, arrowheads, stone implements or tools, human burials, historic docks, structures or not recent (i.e. older than 100 years) vessel ruins. Paleontological remains consist of old animal remains, original or fossilized, such as teeth, tusks, bone, or entire skeletons.
3. SCDOT will have the authority to suspend the work for the purpose of preserving, documenting, and recovering the remains and materials of archeological and paleontological importance for the State. CONTRACTOR shall carry out all instructions of SCDOT for the protection of archeological or paleontological remains, including steps to protect the site from vandalism and unauthorized investigations, from accidental damage and from dangers such as heavy rainfall or runoff.
4. CONTRACTOR's Contract Time and or Contract Price shall be adjusted to the extent CONTRACTOR's cost and /or time of performance have been adversely impacted by the presence of archeological or paleontological remains.

#### **D. Community and Public Relations Plan**

The CONTRACTOR shall provide to SCDOT for review and written approval a Community Relations Plan as part of the Project in accordance with Exhibit 5. The Community Relations Plan shall describe how the CONTRACTOR will actively promote good relationships with local elected officials, the news media, and the community at large. All costs associated with community relations will be included in the Total Project Cost. SCDOT will expect the CONTRACTOR to maintain positive communications with the local community (including public meetings as necessary), the adjacent property owners, and local businesses. The Community Relations Plan shall be submitted within 45 calendar days after NTP.

### **XI. HAZARDOUS MATERIALS**

- A.** The CONTRACTOR is referred to Attachment B for information regarding Hazardous Materials inspections and other environmental documentation regarding Hazardous Materials. The CONTRACTOR shall be responsible for handling, storage, remediation, and disposal of any materials, wastes, substances and chemicals deemed to be a solid waste or hazardous waste under applicable state or federal law, (hereinafter "Hazardous Materials") encountered at the Site which were identified in the Hazardous Materials inspection or other environmental documentation regarding Hazardous Materials provided in Attachment B and the cost of these activities shall be included in the Contract Price.
- B.** If the CONTRACTOR's plan includes demolition, removal, or disposal of existing structures not previously inspected by SCDOT, the Contractor is required to perform lead-based paint and asbestos inspections on the existing structures prior to performing those activities. The cost of the lead-based paint and asbestos inspections shall be included in the Contract Price. Removal of lead-based paint and asbestos and lead-based paint and asbestos containing materials identified by inspections shall be by a qualified independent firm retained by the Department or by negotiating a construction change directive with the CONTRACTOR as outlined in the procedures in Article XI.F.
- C.** If the CONTRACTOR's plan includes demolition, removal, or disposal of existing structures previously surveyed by SCDOT, but the asbestos inspection reports have expired, the CONTRACTOR is required to perform new asbestos inspections on the existing structures prior to performing those activities. The cost of the asbestos inspections shall be included in the Contract Price. The cost of removal, handling, storage, remediation, and disposal of asbestos containing materials identified in the expired inspection reports shall be included in the Contract Price.
- D.** A copy of the lead-based paint and asbestos inspection reports and the notification of demolition or renovation forms must be submitted to SCDHEC at least ten (10) working days prior to demolition of an existing structure. Prior to submitting the reports and forms to SCDHEC, the CONTRACTOR shall obtain the RCE's signature.

The CONTRACTOR is responsible for obtaining all required permits to proceed with the work.

- E.** The CONTRACTOR is responsible for all necessary containment, removal, transportation, and disposal of the subsurface and surface Hazardous Materials identified in inspections or other environmental documentation provided in Attachment B in compliance with all applicable Federal (EPA, OSHA & DOT) and State (SCDHEC & SCDOT) and local (County and Municipality) requirements for Hazardous Materials and worker health and safety. The CONTRACTOR is responsible for obtaining all required permits to proceed with the work.
- F.** Unexpected Hazardous Materials – Upon encountering any unexpected Hazardous Materials, the CONTRACTOR shall follow the procedures as described below:
1. CONTRACTOR shall stop Work immediately in the affected area and duly notify SCDOT and, if required by state or federal law, all government or quasi-government entities with jurisdiction over the Project or site.
  2. Upon receiving notice of the presence of Hazardous Materials, SCDOT will take necessary measures required to verify that the Hazardous Materials are remediated or rendered harmless. Such necessary measures will include SCDOT either (i) retaining qualified independent firm or (ii) negotiating a construction change directive with CONTRACTOR.
  3. CONTRACTOR shall resume Work at the affected area of the Project only after written notice from SCDOT that the (i) Hazardous Materials have been removed or rendered harmless and (ii) all necessary approvals have been obtained from all government and quasi-government entities having jurisdiction over the Project.
  4. CONTRACTOR's Contract Price and/or Contract Time shall be adjusted to the extent CONTRACTOR's cost and/or time of performance has been adversely impacted by the presence of Hazardous Materials.
  5. If a construction change directive is negotiated, the CONTRACTOR shall comply with Article XI.E.
- G.** For purposes of this Project, the Hazardous Material Generator shall be listed as "SCDOT as the generator on behalf of the South Carolina Department of Commerce" of any and all hazardous materials and/or hazardous wastes associated with work on the Project, with the exception that CONTRACTOR shall be the generator for all hazardous materials it, its consultants, subconsultants, subcontractors or suppliers, brings on to the Project or that is brought to the Project by them and subsequently is caused to be released on the Project by the CONTRACTOR, CONTRACTOR's design consultants, subcontractors and suppliers. The foregoing shall not preclude or limit any rights or remedies that SCDOT may have against third parties and/or prior owners, lessees, licensees and occupants of the Project's right of way.

H. SCDOT is not responsible for Hazardous Materials actually brought to the Project by CONTRACTOR, CONTRACTOR's design consultants, subcontractors and suppliers or anyone for whose acts they may be or are liable. SCDOT is not responsible for negligent or willful acts by CONTRACTOR, CONTRACTOR's design consultants, subcontractors and suppliers or anyone for whose acts they may be or are liable relating to Hazardous Materials found at the site. CONTRACTOR shall indemnify, defend and hold harmless SCDOT and SCDOT's officers, directors, employees and agents from and against all claims, losses, damages, liabilities and expenses, including attorney's fees and expenses arising out of or resulting solely from those Hazardous Materials actually brought to the Project or negligent or willful acts relating to Hazardous Materials, or both by CONTRACTOR, CONTRACTOR's design consultants, subcontractors and suppliers or anyone for whose acts they may be or are liable.

## **XII. DEMOLITION, REMOVAL & DISPOSAL OF STRUCTURES**

CONTRACTOR shall be responsible for the demolition, removal and disposal of all structures and their appurtenances within SCDOT Right of Way necessary for the completion of the Project, to include those portions which may extend outside the right of way, but were purchased as a part of the acquisition process. Structures shall include the bridges identified in the scope of work and all buildings acquired for the Project. All necessary permitting shall comply with Articles II.B.4 and IX of the Contract. Removal, handling, and disposal of Hazardous Materials shall be in accordance with Article XI of the Contract. Before demolition of the structures, the CONTRACTOR shall complete and submit a Notification of Demolition and Renovation form to SCDHEC. Prior to submitting the form to SCDHEC, the CONTRACTOR shall obtain the RCE's signature.

## **XIII. DIFFERING SITE CONDITIONS**

- A. "Differing Site Conditions" are defined as concealed or latent physical conditions at the Site that (i) materially differ from the conditions reasonably assumed to exist based on the information contained in the RFP, this Agreement and its Exhibits; or (ii) are of an unusual nature, differing materially from the conditions ordinarily encountered and generally recognized as inherent in the work. For this project, geotechnical/geological conditions WILL NOT be considered as a Differing Site Condition.
- B. Upon encountering a Differing Site Condition, CONTRACTOR shall provide prompt written notice to SCDOT of such condition, which notice shall not be later than twenty (20) days after such condition has been encountered. CONTRACTOR shall provide such notice before the Differing Site Condition has been substantially disturbed or altered and before any work is performed.
- C. Upon written notification, SCDOT will investigate the conditions and if it is determined that the conditions differ materially and cause an increase or decrease in the cost or time required for performance of the work, the Contract will be adjusted. No contract adjustment that results in a benefit to CONTRACTOR will be allowed unless CONTRACTOR has provided the required written notice.

#### **XIV. FORCE MAJEURE**

Delays or failures of performance shall not constitute breach of the Agreement if and to the extent such delays or failures of performance are caused by severe and not reasonably foreseeable occurrences beyond the control of SCDOT or CONTRACTOR, including, but not limited to: Acts of God or the public enemy; expropriation or confiscation of facilities; compliance with any order or request of any governmental authority other than SCDOT or a party in privity with it; a change in law directly and substantially affecting performance of the Project; Acts of War; rebellion or sabotage or damages resulting there from; fires, floods, explosions, or extraordinary accidents; riots or strikes or other concerted acts of workman, whether direct or indirect, or any similar causes, which are not within the control of SCDOT or CONTRACTOR respectively, and which by the exercise of reasonable diligence, SCDOT or CONTRACTOR are unable to prevent. Any expense attributable to such occurrence shall not entitle CONTRACTOR to an adjustment in the Contract Price. Any critical path delay attributable to such an occurrence shall be added to the Contract Time.

#### **XV. WARRANTY**

- A.** CONTRACTOR warrants that it will perform all services in accordance with the standards of care and diligence normally practiced by recognized engineering and construction firms in performing services and obligations of a similar nature. CONTRACTOR warrants that all materials and equipment furnished shall be of good quality and new unless otherwise authorized by SCDOT and that the construction shall conform to the Contract requirements. CONTRACTOR agrees to promptly correct, at its own expense, defects or deficiencies in materials and workmanship that appear prior to and during a period of three (3) years after Final Completion of the Project. This shall include all plant-produced materials (i.e. asphalt, concrete, etc.). CONTRACTOR shall not be responsible for damages caused by SCDOT's failure to provide timely notification of potentially damaged or defective work of which SCDOT had actual knowledge. CONTRACTOR shall properly perform, at the written request of SCDOT made at any time within the warranty period after Final Completion of the Project as defined in Article IV.A.5, all steps necessary to satisfy the foregoing warranty and correct any element of the Project or the services that is defective or does not reflect such standards of care and diligence. The cost of such corrective services shall be CONTRACTOR's responsibility.
- B.** CONTRACTOR further warrants the performance of all bridge components on all structures for three (3) years from Final Completion of the Project. If a component fails to perform properly for any reason, including but not limited to normal wear and tear, the CONTRACTOR shall replace the failed component at no cost to SCDOT.
- C.** The warranty periods begin at Final Completion of the Project. CONTRACTOR shall immediately abate any warranty deficiency that poses an unsafe condition to the public; otherwise deficiencies shall be corrected no later than 30 days from the determination of corrective action. In the event CONTRACTOR, after notice, fails to immediately abate the deficiency or fails to make correction within the prescribed thirty (30) days, SCDOT may have the deficiency corrected. All costs associated

with such correction by SCDOT shall be the responsibility of the CONTRACTOR and his Surety. With respect to any component that is repaired or replaced pursuant to this warranty, the warranty period of that component shall be the longer of one year from repair or replacement of the component or the remainder of the original warranty period.

- D.** CONTRACTOR shall take all steps necessary to transfer to SCDOT any manufacturer's or other third-party's warranties of any materials or other services used in the construction of the Project.

## **XVI. INDEMNITY**

- A.** CONTRACTOR shall indemnify, defend and hold SCDOT harmless from any and all claims, liabilities and causes of action for any fines or penalties imposed on SCDOT by any state or federal agency because of violation by CONTRACTOR or any of its subcontractors of any state or federal law or regulation.
- B.** CONTRACTOR shall indemnify, defend and hold SCDOT harmless from any and all claims, liabilities and causes of action arising out of or resulting from, in whole or in part, the negligence or recklessness of CONTRACTOR or its agents, consultants and/or subcontractors.

## **XVII. TERMINATION AND CANCELLATION**

### **A. Termination for Default**

1. CONTRACTOR shall be in default of the Contract if it:
  - a. Fails to supply a sufficient number of properly skilled workmen, tools, materials and equipment to assure the prompt completion of the work;
  - b. Fails to perform work in accordance with contract requirements and/or refuses to remove or replace rejected materials or unacceptable work;
  - c. Discontinues the prosecution of the work;
  - d. Fails to resume work that has been discontinued within a reasonable time after notice to do so;
  - e. Becomes insolvent or is declared bankrupt or commits any act of bankruptcy or insolvency;
  - f. Allows any final judgment to remain unsatisfied for a period of 15 days;
  - g. Makes an assignment for the benefit of creditors;
  - h. Fails to maintain the Project schedule;
  - i. Commits a substantial breach of the Contract; or



- j. For any other cause whatsoever, fails to carry on the work in an acceptable manner.
2. If CONTRACTOR does not commence work to cure the default within 15 days after receipt of written notice from SCDOT and thereafter diligently prosecute work to completion within a reasonable time as determined by SCDOT, then SCDOT will have full power and authority to terminate CONTRACTOR for default and shall provide written notification of the termination to CONTRACTOR and Surety.
3. Upon termination for default, Surety will have the right to complete the contract and shall be given thirty (30) days, or longer in SCDOT's discretion, in which to resume the work. This procedure shall not in any way serve to extend the contract time. All charges incident to negotiation with the Surety and arranging for work to be resumed, including attorney's fees, shall be charged against CONTRACTOR or Surety as part of the cost of the work.
4. If Surety refuses to complete the work or fails to take over the work promptly as provided by this Agreement, then SCDOT may appropriate or use any or all materials and equipment on the job site as may be suitable and acceptable and may enter into an agreement for the completion of the Contract. All costs and charges incurred by SCDOT together with the cost of completing the work under the Contract will be deducted from any monies due or which may become due CONTRACTOR. If such expense exceeds the sum which would have been payable under the Contract, CONTRACTOR and Surety shall be liable and shall pay to SCDOT the amount of such excess.
5. Upon termination for default, all Project Documents, as defined in Article II.E, shall be surrendered forthwith by CONTRACTOR to SCDOT. SCDOT will be authorized to use the Project documents for the sole purpose of promoting, completing, using, maintaining, upgrading or adding to the Project. This authorization includes allowing design professionals to make changes, corrections, or additions to the Project documents for these purposes.
6. If, after termination, it is determined that the Contractor was not in default, or that the default was excusable, the rights and obligations of the parties shall be the same as if the termination had been issued for the convenience of the State.

#### **B. Termination for Convenience**

1. SCDOT reserves the right to cancel the Work upon ten (10) days written notice to CONTRACTOR. Should the Work be so canceled by SCDOT for convenience, CONTRACTOR shall be paid for the value of the Work, based upon the Schedule of Values, performed to the date of cancellation and demobilization together with any cancellation charges by vendors and subcontractors. CONTRACTOR shall also be entitled to the cost of securing the work, provided such cost is approved by SCDOT. In no event, however, shall the total payment to CONTRACTOR pursuant to such a cancellation exceed the Contract Price.

2. Termination of all or a portion of the Contract shall not relieve CONTRACTOR of any responsibility it would otherwise have for the work completed, or for any claims arising from that work.
3. Upon such termination, all Project Documents, as defined in Article II.E, shall be surrendered forthwith by CONTRACTOR to SCDOT. SCDOT will be authorized to use the Project documents for the sole purpose of promoting, completing, using, maintaining, upgrading or adding to the Project. This authorization includes allowing design professionals to make changes, corrections, or additions to the Project documents for these purposes.

#### **XVIII. DISADVANTAGED BUSINESS ENTERPRISES**

- A. DBE Goal - The DBE goal on this Project is zero (0%) percent. Whether or not there is a DBE contract goal on the contract, the Proposer is strongly encouraged to obtain the maximum amount of DBE participation feasible on the contract. The selected CONTRACTOR is required to report all DBE participation through the DBE Quarterly Reports required by Part B of the SCDOT DBE Supplemental Specifications.
- B. SCDOT'S Right to Audit - SCDOT will have the right to audit all documentation regarding DBE participation in the Project.

#### **XIX. ON-THE-JOB TRAINING REQUIREMENTS**

Not required.

#### **XX. RECORD RETENTION**

- A. CONTRACTOR shall maintain the following documents for a period of three (3) years or a period equal to the warranty period, whichever is longer, after Final Completion of the Project:
  1. All CONTRACTOR samples and test reports;
  2. Daily Diaries and any other documents required to be retained in accordance with the Quality Control Plan.
- B. During the retention period, SCDOT will be granted access to those documents upon reasonable notice. At any time during the retention period, SCDOT will have the option of taking custody of the documents. CONTRACTOR shall obtain a written release from SCDOT prior to destroying the records after the retention period.

#### **XXI. AS-BUILTS**

- A. In addition to those documents set forth elsewhere in this Agreement, CONTRACTOR shall provide to SCDOT prior to Final Completion, complete sets of as-built drawings (See Article XXI.D for details). As-built plans consist of the final version of the design plan CADD drawings that incorporate all changes, including

any adjustments, relocations, additions and deletions that occurred during construction. CONTRACTOR shall certify that the as-built plans are a true and correct representation of the work as constructed. If any design changes occur during construction, the plan sheets (or any other “job site record document” with a seal) revised after award of contract shall include a complete accounting and detail of the revisions and design changes. The P.E. responsible for the revisions shall seal each altered plan sheet (or any other “job site record document” with a seal). This documented information is to be part of the As-Built Plan requirements. The CONTRACTOR shall develop as-built plans in accordance with the SCDOT Manual of Instructions for the Preparation of As-Built Plans, edition effective as of the release of the Final RFP.

- B.** Information regarding major revisions to the plans shall be noted in a revision box on the plans. The information listed in the revision box shall include: the initiator of the revision, a brief explanation of the nature of the revision, and acceptance and approval from CONTRACTOR, along with associated dates.
- C.** In addition to the revisions that incorporated changes during construction, the as-built plans shall include the following information gathered during construction:
  - 1. The location and elevation of foundations remaining below grade.
  - 2. The final profile of each bridge constructed. The profile shall include the elevation along the centerline (or as specified by SCDOT) and a line three feet inboard of each gutter line. Points on the profile shall be taken at no greater than 25-foot intervals and shall include the beginning and end of each span.
  - 3. If any structure has pile foundations, information concerning the pile driving operation shall be listed to include pile and driving equipment data, final pile bearing, elevation of pile tip when plan bearing was obtained, final pile tip elevation, penetration into the ground, and PDA or WEAP analysis data. This information shall be entered on each footing or bent sheet, or be included as a new sheet inserted immediately following the pertinent footing or bent sheet.
  - 4. If any structure has drilled shaft foundations, information concerning the installation of the shaft shall be listed to include the drilled shaft report. This information shall be entered on each footing or bent sheet, or be included as a new sheet inserted immediately following the pertinent footing or bent sheet.
  - 5. The final horizontal location of all existing and relocated utility lines and structures that are within the right-of-way. Include approved Utility Agreements, No Cost/No Conflict Letters, and Encroachment Permits.
  - 6. The final location and elevations of all pipes, culverts, and drainage structures.
  - 7. To include all right-of-way revisions, permissions, and an updated right-of-way data sheet to show the date and manner of acquisition of each tract

- D. As-built plans shall be submitted as two (2) full size (36 inch x 22 inch) copies and one (1) copy on compact disc in a format acceptable to SCDOT. The levels and symbology of the as-built CADD drawings shall conform to SCDOT standard levels and symbology used to develop the design drawings for the Project.

## **XXII. ESCROW PROPOSAL DOCUMENTS**

The Contractor shall submit bid documentation used to prepare the technical and cost proposals for this contract to the Department in accordance with the Supplemental Specification entitled Escrow Bid Documentation dated October 1, 2014.

## **XXIII. DISPUTE RESOLUTION**

- A. Each party hereby waives a trial by jury regarding any dispute between them arising out of this Contract and any such trial will be a non-jury trial before the South Carolina Circuit Court in Richland County.
- B. In the event of a dispute between the parties, it shall be a condition precedent to litigation that the parties submit the dispute to the Standing Dispute Review Board pursuant to the Claims Procedure set forth in the Project Supplemental Specifications.
- C. CONTRACTOR consents that any papers, notices, or process necessary or proper for the initiation or continuation of any disputes, claims, or controversies relating to the Agreement; for any court action in connection therewith; or for the entry of judgment on any award made, may be served on CONTRACTOR by certified mail (return receipt requested) addressed to CONTRACTOR at the address provided in Article XXVI. Notice by certified mail is deemed duly given upon deposit in the United States mail.

## **XXIV. SCDOT'S AGENT**

SCDOT will appoint an individual who will be authorized to act on behalf of SCDOT, with whom CONTRACTOR may consult at all reasonable times, and whose instructions and decisions will be binding upon SCDOT as to all matters pertaining to this Agreement and the performance of the parties hereunder.

## **XXV. ASSIGNABILITY**

The Contract shall not be assignable by CONTRACTOR without the prior written consent of SCDOT. SCDOT may assign the Contract without the consent of CONTRACTOR.

## **XXVI. GENERAL PROVISIONS**

- A. This Agreement shall be governed by and interpreted in accordance with the substantive laws of the State of South Carolina.
- B. Headings and titles of the various parts of this Agreement are for convenience of reference only and shall not be considered in interpreting the text of this Agreement.

Modifications or amendments to this Agreement must be in writing and executed by duly authorized representatives of each party.

- C. In the event that any portion or all of this Agreement is held to be void or unenforceable, the parties agree to negotiate in good faith to reach an equitable agreement which shall affect the intent of the parties as set forth in this Agreement.
- D. All notices pertaining to this Agreement shall be in writing and, if to SCDOT, will be sufficient when sent registered or certified mail to SCDOT addressed as follows:

Deputy Secretary for Engineering  
South Carolina Department of Transportation  
Post Office Box 191  
Columbia, South Carolina 29202-0191

All notices to CONTRACTOR shall be sufficient when sent registered or certified mail to CONTRACTOR addressed as follows:

(Insert CONTRACTOR'S address here)

- E. The Contract Documents set forth the full and complete understanding of the parties as of the Effective Date defined herein, and supersedes any and all agreements and representations made or dated prior thereto.
- F. The parties make no representations, covenants, warranties or guarantees, express or implied, other than those expressly set forth herein. The parties' rights, liabilities, responsibilities and remedies within respect to the work shall be exclusively those expressly set forth in this Agreement.
- G. In no event shall any failure by either party hereto to fully enforce any provision to this Agreement be construed as a waiver by such party of its right to subsequently enforce, assert or rely upon such provision.
- H. Nothing in this Agreement is intended to create any contract rights for any party other than SCDOT and CONTRACTOR, nor are any third-party beneficiary rights intended to be created hereby.

I-26 Volvo Interchange  
Berkeley County

IN WITNESS WHEREOF, the parties hereto have executed this Agreement as of the Effective Date defined herein. The Effective Date is defined as the date signed by the Director of Construction on behalf of South Carolina Department of Transportation.

Witnesses:

\_\_\_\_\_  
\_\_\_\_\_

SOUTH CAROLINA DEPARTMENT  
OF TRANSPORTATION

By: \_\_\_\_\_  
Todd Steagall, P.E.  
Director of Construction

Date: \_\_\_\_\_

\_\_\_\_\_

Recommended:

\_\_\_\_\_  
Jeff Elliott, P.E.  
Contract Administration Engineer

Witnesses:

\_\_\_\_\_  
\_\_\_\_\_

CONTRACTOR

\_\_\_\_\_  
*Name of Contractor*

By: \_\_\_\_\_

Its: \_\_\_\_\_

**CERTIFICATION OF CONTRACTOR**

I hereby certify that I am the duly authorized representative of CONTRACTOR and that neither I nor the above CONTRACTOR I here represent has:

- a) employed or retained for a commission, percentage, brokerage, contingent fee, or other consideration, any firm or person (other than a bona fide employee working solely for me or the above CONTRACTOR) to solicit or secure this contract;
- b) agreed, as an express or implied condition for obtaining this contract, to employ or retain the services of any firm or person in connection with carrying out the contract, or
- c) paid, or agreed to pay, to any firm, organization or person (other than a bona fide employee working solely for me or the above CONTRACTOR) any fee, contribution, donation, or consideration of any kind for, or in connection with, procuring or carrying out the contract except as here expressly stated (if any);
- d) either directly or indirectly, entered into any agreement, participated in any collusion, or otherwise taken any action, in restraint of free competitive bidding in connection with the submitted proposal.

By execution of this Agreement, CONTRACTOR certifies CONTRACTOR and all CONTRACTOR's consultants, sub-consultants, contractors, employees and agents will comply with South Carolina's Ethics, Government Accountability, and Campaign Reform Act of 1991, as amended. The following statutes require special attention: (a) Offering, giving, soliciting, or receiving anything of value to influence action of public employee - §8-13-790, 8-13-705, 8-13-720; (b) Recovery of kickbacks - §8-13-790, (c) Offering, soliciting or recovering money for advice or assistance of public official - §8-13-720, (d) Use or disclosure of confidential information - §8-13-725, (e) Persons hired to assist in the preparation of specifications or evaluation of bids - §8-13-1150, (f) Solicitation of state employees - §8-13-755, 8-13-760 and §8-13-725, (g) False Claims Act -§16-13-240. The state may rescind any contract and recover all amounts expended as a result of any action taken in violation of this provision.

I acknowledge that this certificate is to be furnished to the Department, the Federal Highway Administration, and the U. S. Department of Transportation, and is subject to applicable State and Federal laws, both criminal and civil.

I acknowledge that giving false, misleading, or incomplete information on this certification may subject me to prosecution under Section 16-9-10 of the South Carolina Code of Laws.

CONTRACTOR

\_\_\_\_\_  
*Name of Contractor*

By: \_\_\_\_\_

Date: \_\_\_\_\_

Its: \_\_\_\_\_

**CERTIFICATION OF DEPARTMENT**

I hereby certify that I am the Director of Construction for the South Carolina Department of Transportation (SCDOT) of the State of South Carolina and that the above CONTRACTOR or its representative has not been required, directly or indirectly, as an express or implied condition in connection with obtaining or carrying out this agreement to:

- a) employ or retain, or agree to employ or retain, any firm or person, or
- b) pay, or agree to pay, to any firm, person, or organization, any fee, contributions, donations, or consideration of any kind, except as here expressly stated (if any).

I acknowledge that this certificate is to be furnished to the Federal Highway Administration, and U. S. Department of Transportation, and is subject to applicable State and Federal laws, both criminal and civil.

SOUTH CAROLINA DEPARTMENT OF  
TRANSPORTATION

BY: \_\_\_\_\_

TITLE: DIRECTOR OF CONSTRUCTION

Date: \_\_\_\_\_



### **DRUG-FREE WORKPLACE CERTIFICATION**

In accordance with Section 44-107-30, South Carolina Code of Laws (1976), as amended, and as a condition precedent to the execution of this agreement, the undersigned, who is an authorized representative of the CONTRACTOR certifies on behalf of the CONTRACTOR that the PROPOSER will provide a drug-free workplace by:

- (1) publishing a statement notifying employees that the unlawful manufacture, distribution, dispensations, possession, or use of a controlled substance is prohibited in the CONTRACTOR's workplace and specifying the actions that will be taken against employees for violations of the prohibition;
- (2) establishing a drug-free awareness program to inform employees about:
  - (a) the dangers of drug abuse in a workplace;
  - (b) the person's policy of maintaining a drug-free workplace;
  - (c) any available drug counseling, rehabilitation, and employee assistance programs; and
  - (d) the penalties that may be imposed upon employees for drug violations;
- (3) making it a requirement that each employee to be engaged in the performance of the agreement be given a copy of the statement required by item (1);
- (4) notifying the employee in the statement required by item (1) that, as a condition of employment of this agreement, the employee will:
  - (a) abide by the terms of the statement; and
  - (b) notify the employer of any criminal drug statute conviction for a violation occurring in the workplace no later than five days after the conviction;
- (5) notifying the South Carolina Department of Transportation within ten days after receiving notice under item (4)(b) from an employee or otherwise receiving actual notice of the conviction;
- (6) imposing a sanction on, or requiring the satisfactory participation in a drug abuse assistance or rehabilitation program by, any employee convicted as required in Section 44-107-50; and
- (7) making a good faith effort to continue to maintain a drug-free workplace through implementation of items (1), (2), (3), (4), (5), and (6)

By execution of this Agreement CONTRACTOR certifies CONTRACTOR and all CONTRACTOR's consultants, sub-consultants, contractors, employees and agents will comply with all applicable provisions of the Drug-Free Workplace Act, Title 44, Chapter 107 of the South Carolina Code of Laws, as amended.

CONTRACTOR: \_\_\_\_\_  
(Signature)

# **EXHIBIT 1**

## **COST PROPOSAL BID FORM**

**PROPOSED COST PROPOSAL BID FORM**  
**FOR**  
**INTERSTATE 26 VOLVO INTERCHANGE**  
**BERKELEY COUNTY**

*The Cost Proposal Bid Form*, as submitted by the selected PROPOSER, will be included with the completed agreement.

# **EXHIBIT 2**

## **SCHEDULE OF VALUES**

**SCHEDULE OF VALUES**  
**FOR**  
**INTERSTATE 26 VOLVO INTERCHANGE**  
**BERKELEY COUNTY**

A Schedule of Values, submitted by the selected PROPOSER and approved by SCDOT, will be included with the completed agreement.

# **EXHIBIT 3**

## **SCOPE OF WORK**

EXHIBIT 3 – SCOPE OF WORK
---------------------------

The project consists of all work necessary to complete the design and construct a new interchange along I-26 in Berkeley County that will connect I-26 to the future Volvo Car Drive on the north side of I-26. In addition, the project will include the construction of a portion of Volvo Car Drive and resurfacing and cross slope correction of existing mainline I-26 within the project limits to satisfy current superelevation standards for the existing horizontal geometry.

The new interchange shall provide access from I-26 to the new Volvo Car Drive which leads to Camp Hall Commerce Park and the Volvo Manufacturing Facility. The new interchange will be located along I-26 at approximate mile marker 189 which is approximately two miles east of SC 27/Ridgeville Road (Exit 187) and approximately five miles west of S-16/Jedburg Road (Exit 194). **I-26 shall remain at grade in each direction.**

The Contractor shall provide a three-level, three-leg directional interchange that connects I-26 to the Camp Hall Commerce Park via Volvo Car Drive. Construct directional ramps for all movements. Using grade separated structures, provide free-flowing ramps from I-26 to Volvo Car Drive and from Volvo Car Drive to I-26. At a minimum, construct two-lane, one-way ramps heading to and from Charleston with two lane exits and entrances on I-26. Construct one-lane, one-way ramps heading to and from Orangeburg. If an alternative type of interchange is proposed, an ATC must be prepared and submitted for review and approval.

The Contractor shall coordinate its activities with all work being completed by others at the Camp Hall Commerce Park and in the vicinity of the project. Construction plans for Volvo Car Drive are included in Attachment C.

The Preliminary Utility Report is included in Attachment C. The report describes proposed utility facilities that are currently being or planned to be installed by others during the Project. The Contractor shall avoid all proposed utility facilities that are shown in this report. The Contractor shall be responsible for all cost and schedule impacts related to these utility facilities.

For a full understanding of the scope of the project and the criteria of the construction items needed for this project, review Exhibit 4, Exhibit 5, Exhibit 6 and Attachment B.

# **EXHIBIT 4**

## **PROJECT DESIGN CRITERIA**



EXHIBIT 4 – PROJECT DESIGN CRITERIA
-------------------------------------

This exhibit details the criteria by which the project shall be designed and constructed. These criteria are divided into subsections as listed below:

Exhibit 4a – Roadway Design Criteria

Exhibit 4b – Structures Design Criteria

Exhibit 4c – Pavement Design Criteria

Exhibit 4d – Traffic Design Criteria

Part 1 – Signing and Pavement Markings

Part 2 – Work Zone Traffic Control

Exhibit 4e – Hydraulic Design Criteria

Exhibit 4f – Geotechnical Design Criteria

Exhibit 4g – Environmental Design Criteria

**DESIGN REFERENCES**

This exhibit describes the general design considerations and criteria for the proposed roadway approaches, hydraulics, structures, and surveys.

Design standards shall be in accordance with the following design references as supplemented or amended by Sections 4a, 4b, 4c, 4d, 4e, 4f, and 4g of this Exhibit. Any variation in design from the included information shall require written approval from SCDOT.

- AASHTO A Policy on Design Standards Interstate System, 2005
- AASHTO Drainage Manual, 2014 first edition
- AASHTO Guide for the Development of Bicycle Facilities, 1999
- AASHTO Guide for the Planning, Design, and Operation of Pedestrian Facilities, 2004
- AASHTO Highway Drainage Guidelines, 2007
- AASHTO LRFD Bridge Design Specifications, 2012, Sixth Edition (with 2013 Interim Revisions)
- AASHTO Roadside Design Guide, with 2006 Chapter 6 update, 3<sup>rd</sup> Edition
- AASHTO Standard Specifications for Highway Bridges, 17<sup>th</sup> Edition
- AASHTO Standard Specifications for Structural Supports for Highway Signs, Luminaires and Traffic Signals, Sixth Edition
- AASHTO/AWS D1.5M/D1.5:2010 Bridge Welding Code, with 2011 interims
- AASHTO “Standard Specifications for Transportation Materials and Methods of Sampling and Testing” 2013 Thirty-Third Edition
- FEMA Regulations, 44CFR Chapter 1
- FHWA Manual on Uniform Traffic Control Devices, 2009
- FHWA Publication No. FHWA NHI-07-071 Earth Retaining Structures, 2008
- NCHRP Report 672, Roundabouts: An Informational Guide – Second Edition
- SCDHEC NPDES Construction Permit # SCR160000
- SCDHEC NPDES MS4 Permit # SCS040001
- SCDOT Access and Roadside Management Standards, August 2008 with updates
- SCDOT Americans with Disabilities Act Transition Plan, January 2009
- SCDOT Bridge Design Manual, 2006
- SCDOT Bridge Design Memoranda, effective between July 1, 2006 and the Final RFP release date
- SCDOT Bridge Drawings and Details, effective as of the Final RFP release date
- SCDOT Engineering Directives, effective as of the Final RFP release date
- SCDOT Geotechnical Design Manual, 2010 Edition (Version 1.1)
- SCDOT Geotechnical Drawings and Details, effective as of the Final RFP release date
- SCDOT Highway Design Manual, 2003, with updates effective as of the Final RFP release date and supplemented with AASHTO A Policy on Geometric Design of Highways and Streets, 2001
- SCDOT Instructional Bulletins, effective as of the Final RFP release date
- SCDOT Pavement Design Guidelines, July 2008 Edition

## EXHIBIT 4 – PROJECT DESIGN CRITERIA

- SCDOT Plan Preparation Guide, 2000
- SCDOT Preconstruction Advisory Memorandums, effective as of the Final RFP release date
- SCDOT Preconstruction Design Memorandum, effective as of the Final RFP release date
- SCDOT Preconstruction Survey Manual, effective as of the Final RFP release date
- SCDOT Procedures and Guidelines for Work Zone Traffic Control Design, effective as of the Final RFP release date
- SCDOT Qualified Product Lists, effective as of the Final RFP release date
- SCDOT Requirements for Hydraulic Design Studies, May 2009
- SCDOT Road Design Reference Material for Consultant Prepared Plans, June 2010
- SCDOT Roadside Plants to Avoid/Trees with Limitations on R/W, October 2014
- SCDOT Seismic Design Specifications for Highway Bridges, 2008 (Version 2.0)
- SCDOT Standard Drawings, effective as of the Final RFP release date
- SCDOT Standard Specifications for Highway Construction, 2007
- SCDOT Stormwater Quality Design Manual, effective as of the Final RFP release date;
- SCDOT Supplement to the MUTCD
- SCDOT Supplemental Specifications (2007), effective as of the Final RFP release date
- SCDOT Supplemental Technical Specifications, effective as of the Final RFP release date
- SCDOT Traffic Signal Design Guidelines, 2009 with updates
- SCDOT Traffic Signal Material Specifications, effective as of the Final RFP release date
- SCDOT Traffic Signal Supplemental Specifications, effective as of the Final RFP release date
- SCDOT Street Trees and Sidewalk Planting Suggestions, May 2013
- SCDOT Vegetation Management Guidelines, effective as of the Final RFP release date
- South Carolina State Water Law
- The Rule on Work Zone Safety and Mobility, Policy and Guidelines
- The State Stormwater and Sediment and Erosion Control Regulations administered by DHEC, 26 S.C. Code Ann. Regs. 72-405 (Supp. 1995) et seq.
- TRB Highway Capacity Manual, 2010
- United States Access Board’s Revised Draft Guidelines for Accessible Public Rights-of-Way (PROWAG), November 23, 2005
- International Building Code, effective as of the Final RFP release date
- ACI 318 Building Code and Commentary
- ASCE’s “Minimum Design Loads for Buildings and Other Structures”, latest edition

# **EXHIBIT 4a**

## **ROADWAY DESIGN CRITERIA**

**1.0 GENERAL**

Prepare the roadway geometric design for the project using the design standards and criteria that are most appropriate based on design speed, functional classification, design traffic volumes, right-of-way, and aesthetics. The design elements shall include, but not be limited to, the horizontal and vertical alignments, lane widths, shoulder widths, median widths, sight distance, clear zone, cross slopes, and side slopes.

**2.0 CRITERIA**

Classify the terrain as level on all routes within the scope of work. Use the WB-62 design vehicle for all geometric design with a WB-67 design vehicle to evaluate swept paths and overhangs.

**2.1 Functional Classification**

The functional classification for each roadway is as follows:

- Interstate 26 Rural Arterial – Freeways
- Interchange Ramps Rural Arterial – Freeways

Interchange Cross-Over Road

- Volvo Car Drive Rural Collector (ADT Over 2000)

**2.2 Design Speed**

Interstate

- Interstate 26 70 mph

Interchange Ramps

- Ramps 45 mph

Interchange Cross-over Roads

- Volvo Car Drive 45 mph

**2.3 Cross Sectional Elements**

Develop traffic lane, shoulder, and median widths in compliance with SCDOT Highway Design Manual. See Typical Sections in Attachment B.

Interchange Cross-over Roads

- Median 4 ft. minimum raised concrete

## 2.4 Vertical Curves, Grades, and Clearances

Develop vertical curves, grades, and clearances in compliance with SCDOT Highway Design Manual.

Use grade adjusted K values where the downgrades are 3 percent or greater.

Do not use spline grades. Spline grades are only acceptable on the ramps within the limits of the gore areas.

## 2.5 Cross Slopes

Develop cross slopes in compliance with SCDOT Highway Design Manual.

- Shoulder (paved) 4 ft. or less                      Match travel way pavement slope
- Shoulder (paved) greater than 4 ft.                      24:1
- Ramps acceleration and deceleration lanes                      36:1

The existing cross slope of both lanes in each direction of I-26 within the limit of the project is approximately 2% toward the inside of an existing horizontal curve. This curve does not require superelevation. Correct the cross slope to produce a normal crown in the center of the two westbound and eastbound lanes, by overlay buildup.

## 2.6 Clear Zones

### Mainline Interstate and Ramps

Use the SCDOT HDM (2003 with updates) Chapter 14 and the *Roadside Design Guide* (AASHTO) edition 2006 with Chapter 6 Update, 3<sup>rd</sup> Edition based on traffic volumes, design speed, and slopes. Do not limit the clear zones provided in Figure 14.3A in the SCDOT HDM (2003 with updates) to 30 feet as indicated as a possibility in the footnote for this figure. When a range of values is shown, select higher value. SCDOT does not typically use a 3H:1V fill slope. See the *Roadside Design Guide* (AASHTO) edition 2006 with Chapter 6 Update, 3<sup>rd</sup> Edition for clear zone calculations where a 3H:1V fill slope is used. Use 3H:1V fill slopes only where fill heights are required to match existing conditions and clear zone can be obtained within the Project limits.

At overpasses over mainline I-26 provide horizontal clearances as defined in Exhibit 4b and Attachment B.

At overpasses not over mainline I-26 establish horizontal clearances based on clear zone values provided in Figure 14.3A and as defined in Attachment B. The lower values in Figure 14.3A may be utilized to define the distance to the traffic face of barrier.

For those areas where no guardrail currently exists, design fill and cut slopes to

obtain clear zones and to avoid the need for protection. In areas where new right-of-way, wetland impacts, or impacts to frontage roads or immovable obstructions would be a result of achieving the clear zone requirement, protect substandard areas contingent upon receiving SCDOT approval.

Where existing fill and cut slopes or other hazards are presently protected by guardrail, replace damaged and/or substandard guardrail and extend/install new guardrail at locations that do not meet current standard. Also, clear and grind behind guardrail in accordance with SCDOT Vegetation Management Guidelines.

#### Any Other Roads

Use the SCDOT HDM (2003 with updates) Chapter 14 and the *Roadside Design Guide* (AASHTO) edition 2006 with Chapter 6 Update, 3<sup>rd</sup> Edition based on traffic volumes, design speed, and slopes.

Provide clear zone for any facilities using curbs on this project in compliance with SCDOT HDM (2003 with updates) Chapter 14.

## **2.7 Ramps**

Develop ramps in compliance with SCDOT Highway Design Manual except where otherwise noted.

Ramp shall be parallel with a minimum acceleration/deceleration lane length of 1,500 feet. Two-lane ramps shall be designed with a minimum of two 1,500 foot lengths of acceleration/deceleration lanes.

## **2.8 Roadside Barriers**

Develop roadside barriers in compliance with SCDOT Highway Design Manual. Include the following items in the work:

Guardrail: Ensure that all new guardrail and end treatments are listed on the Qualified Products Policies & Listings.

Provide guardrail median barrier protection at each new bridge that crosses I-26.

Provide paving under guardrail in accordance with the guidance found in the Exhibit 5, Special Provisions Section 403.

Where right of way or environmental impacts dictate that standard guardrail shoulder break cannot be built use additional length guardrail posts with compressed guardrail shoulder break contingent upon receiving SCDOT approval.

Do not use three-beam guardrail with critical offset posts at the bridge piers.

Cable Median Barrier: Along I-26 mainline, within the project limits, provide median cross-over protection. Maintain existing median cable barrier. Ensure

compliance with Standard Drawings. Prior to modifying the existing median cable barrier, the Contractor shall obtain permission from the RCE. Only a single-run of median cable barrier is allowed.

## **2.9 Right-Of-Way and Control Of Access**

If right-of-way is required, secure right-of-way in accordance with Uniform Relocation Assistance and Real Property Acquisition Policies Act of 1970 (Public Law 91-646), as amended and revise environmental document, if needed.

Where it becomes necessary to construct retaining walls to contain cut slopes, establish the right-of-way limit a minimum of 1.2 times the wall height behind the fill face of the wall. Where it becomes necessary to construct retaining walls to contain fill slopes, establish the right-of-way limit as the lesser of either 15 feet beyond the exposed face of the wall or 1.2 times the wall height beyond the exposed face of the wall. In addition, right-of-way must completely cover all retaining wall footings and wall anchorages. Depending upon the design of the wall, additional right of way may be required to construct the wall.

Secure a minimum right-of-way width of 75 feet on each side of the centerline and minimum 75 feet from each end of bridges; refer to SCDOT Highway Design Manual Chapter 30 Section 30.3.12.

Maintain fully controlled access along interstate, all interchanges, and ramp intersections. Control of Access will extend to the end of the project on Volvo Car Drive. Follow SCDOT and FHWA guidelines for Control of Access at interstate interchanges.

## **3.0 DELIVERABLES**

Subject all submittals to SCDOT to a thorough QC review prior to submittal. Ensure RFC plan submittals to SCDOT are signed and sealed by the State of South Carolina licensed Professional Engineer of Record.

### **3.1 Preliminary Plans**

Submit to the SCDOT:

- Two half-size sets of preliminary plans that include, at a minimum: title sheet, roadway typical section, right-of-way data sheet, and strip map including property closures, roadway plan and profile, cross sections, clearing limits on plan view and cross sections, drainage features, existing right-of-way, proposed right-of-way, and preliminary geotechnical reports.
- An electronic submittal to contain an Adobe PDF file of the plans with sheet size 22”x36” in landscape format along with an Adobe PDF file of the reports.



- Any design calculations requested in writing by SCDOT.
- The conceptual work zone traffic control plans with Preliminary Plans ~~if right-of-way plans are not anticipated.~~

### 3.2 **Final Plans**

Submit to the SCDOT:

- Two half-size sets of final plans that include, at a minimum: title sheet, summary of estimated quantities, roadway typical section, right-of-way data sheet, and strip map including property closures, roadway plan and profile, cross sections, drainage design, sediment and erosion control design, existing right-of-way ~~that was acquired by others for this Project,~~ proposed right-of-way, proposed barrier locations, final geotechnical and hydraulic reports, work zone traffic control plans (including temporary signal plans), signing plans, and pavement markings plans.
- An electronic submittal to contain an Adobe PDF file of the plans with sheet size 22”x36” in landscape format along with an Adobe PDF file of the reports.
- Any design calculations requested in writing by SCDOT.
- After submitting final plans for review, advise SCDOT of all changes made to the plans that are not made to address SCDOT comments prior to submittal of RFC plans.

### 3.3 **Release for Construction (RFC) Plans**

For roadway plans, provide two full size sets, two half size sets, and one electronic copy of RFC Plans to SCDOT. Insert RFC Plans into plan folders as detailed in the SCDOT Plan Preparation Guide.

# **EXHIBIT 4b**

## **STRUCTURES DESIGN CRITERIA**

## 1.0 GENERAL

Exhibit 4b contains requirements for:

- bridges,
- retaining walls,
- box culverts and box culvert extensions, and
- concrete median barriers and bridge pier protection.

## 2.0 CRITERIA

### 2.1 Bridges

#### 2.1.1 Bridge Design

Design all bridges in accordance with the requirements of the AASHTO LRFD Bridge Design Specifications. Use the HL-93 design live loading.

#### 2.1.2 Seismic Design

In accordance with the SCDOT Seismic Design Specifications for Highway Bridges, the Bridge Operational Classification (OC) for each bridge is “II.”

#### 2.1.3 Bridge Roadway Widths

Construct the bridges with bridge roadway widths that are equal to or greater than the approach roadway widths (traveled way plus median and shoulders) that are specified in Exhibit 4a.

#### 2.1.4 Vertical Clearances

Provide a minimum of 17'-0" of vertical clearance under new bridges that cross over I-26 and the interchange ramps. In addition, provide 17'-0" of vertical clearance over the future section of I-26.

#### 2.1.5 Horizontal Clearances

Provide horizontal clearances under the new overpasses as shown on the drawing entitled “Horizontal Clearance Requirements under New Overpasses” in Attachment B.

#### 2.1.6 Superstructure Types

For this project, Section 12.3.3 of the SCDOT Bridge Design Manual does not apply. Allowable superstructure types are outlined in Sections 12.3.2.1, 12.3.2.2, 12.3.2.3, and 12.3.2.4 of the SCDOT Bridge Design Manual.

For prestressed concrete girder superstructures, use prestressed concrete girders that are “I” shaped. Design prestressed concrete girders so that the algebraic sum of the beam camber at prestress transfer due to prestress force, the beam dead load deflections due to non-composite dead load, and superimposed dead load deflections due to applied superimposed dead loads results in a positive (upward) camber. Include the dead load from the future wearing surface in the determination of camber.

For steel welded plate girder superstructures, use structural steel girders that are “I” shaped. For steel welded plate girder and steel rolled beam superstructures, use structural steel that conforms to the requirements of AASHTO M 270 and paint the steel in accordance with Section 710 of the Standard Specifications.

At each support of prestressed concrete girder, steel welded plate girder, and steel rolled beam superstructures, connect all beams and girders to the substructure using anchor bolts.

Detail all construction stages for girder bridges to consist of a minimum of two lines of girders.

Floorless culverts are classified as "Other Structure Types" (Section 12.3.3 of the SCDOT Bridge Design Manual) and are not permitted for this project.

#### 2.1.7 Concrete Strengths

In prestressed concrete piles and beams, concrete design strengths are not allowed to exceed 8,000 and 10,000 psi maximum, respectively. Construct all cast-in-place concrete bridge components with Class 4000 concrete except as noted in Section 2.1.9. Construct all precast concrete bridge components with concrete having a minimum compressive strength of 5000 psi.

#### 2.1.8 Final Finish of Exposed Concrete Surfaces

Final surface finish is not required on this project.

Apply an Anti-Graffiti Coating to exposed concrete surfaces of bridge abutment walls, including precast panels and coping of MSE Walls.

#### 2.1.9 Lightweight Concrete

Lightweight Concrete is only permitted in cast-in-place deck slabs and barrier parapets. Use lightweight concrete that conforms to the requirements of the Sand Lightweight Concrete Special Provision in Exhibit 5. When calculating dead loads, include a minimum allowance of 7 pounds per cubic foot for reinforcing steel.

#### 2.1.10 Post-Tensioning

Post-tensioning is not permitted for this project.

#### 2.1.11 Bridge Decks

For girder and beam spans, construct bridge decks with reinforced cast-in-place concrete that covers the entire length of the girders and beams. Extend the deck slab a minimum of 1½ inches and a maximum of 12 inches past the back face of the railing.

Apply a transverse Grooved Surface Finish to bridge decks in accordance with Subsection 702.4.16 of the Standard Specifications for Highway Construction.

Make the connection of the reinforcing of decks between stages by lap-splice or mechanical splice.

Asphalt overlays are not permitted on bridge decks.

#### 2.1.12 Stay-in-Place Bridge Deck Forms

The Contractor may use permanent stay-in-place bridge deck forms for concrete deck slabs between new beams and girders. Fabricate permanent stay-in-place bridge deck forms and supports from steel conforming to ASTM A 446/A 653, Grades 40 or 50, and having a coating class of G165 in accordance with ASTM A 525. Do not use fillers in the flutes of the stay-in-place forms. Fill form flutes with concrete as the deck slab is placed. Do not use permanent stay-in-place steel bridge deck forms in bays in which longitudinal deck construction joints are located and in bays between stages.

#### 2.1.13 Approach Slabs

When roadway pavement approaching the bridge is concrete, make the end of the approach slab perpendicular to the roadway centerline. At skewed bridges, do not step the approach slab at the approach pavement end. In addition, provide a minimum length of 20 feet along the shortest longitudinal edge of the slab, construct the approach slab at grade with a minimum thickness of 12 inches, detail 2.5 inches of concrete cover to the top reinforcing bars, detail an armor plate at the roadway approach ends of the approach slabs, and apply a transverse Grooved Surface Finish in accordance with Subsection 702.4.16 of the Standard Specifications for Highway Construction.

#### 2.1.14 Barriers

Use the SCDOT Standard Barrier Parapet. At ends where three beam guardrail is required, detail the barrier using the standard barrier transition

details shown on the Bridge Drawings and Details. Detail the barrier parapet parallel to the edge of the adjacent travel lane.

2.1.15 Bridge Drainage

Design and construct the bridge deck drainage and bridge end drainage to ensure that the minimum requirements of the SCDOT Bridge Design Manual are met and that erosion of the end fill slopes is prevented due to run off at the bridge ends.

2.1.16 Pile Sizes and Types

Minimum pile sizes and acceptable pile types are listed below. No other pile types are permitted.

PILE TYPE	MINIMUM SIZE
Steel H-Piles	HP12x53
Steel Pipe Piles	12" Diam. (min. wall thickness equal to 1/2")
Solid Prestressed Concrete Piles	18" Square
Prestressed Concrete Pile Points	W8x58

2.1.17 Steel Pipe Pile Connection Details

The pile connection detail described in Item 2 of Section 19.2.6.3 of the SCDOT Bridge Design Manual does not apply for this project. Terminate steel pipe piles at the bottom of the end bent cap and footing. Connect the piles to the cap and footing using a reinforced concrete infill, with the reinforcing extending into the cap or footing.

2.1.18 Drilled Shaft Diameters

SCDOT Bridge Design Memorandum DM0111 contains a requirement to detail the portion of shaft below the construction casing with a diameter that is six inches smaller than the diameter of the casing. This six-inch reduction requirement does not apply to this project. For this project, detail the portion of the shaft below the bottom of the construction casing, whether in soil or rock, with a diameter that is at least two inches smaller than the diameter of the casing.

2.1.19 Crosshole Sonic Logging (CSL) Testing

Install Crosshole Sonic Logging (CSL) access tubes in all drilled shafts in accordance with the SCDOT Standard Specifications for Highway Construction, 2007 Edition. SCDOT will conduct CSL testing on all of the shafts.

### 2.1.20 Substructures

Construct Interior Bents using cast-in-place reinforced concrete bent caps and columns supported on cast-in-place reinforced concrete drilled shafts or pile footings. Deep foundations are required to extend below any compacted fill.

Set the tops of footings in accordance with Section 19.5.5 of the SCDOT Bridge Design Manual. In cases where there is pavement above the footing, locate the top of footing a minimum of two feet below the bottom of the base course.

If a drilled shaft is extended above ground, above the scour line, or through liquefiable soil, structurally design the shaft as a column and detail the longitudinal reinforcing steel with a maximum spacing of 8 inches center-to-center.

Construct end abutments as either vertical abutments or spill through abutments (2:1 maximum slope). Construct vertical abutments and vertical abutment wing walls using cast-in-place reinforced concrete or MSE walls. For bridges crossing a highway, construct the vertical abutment and vertical abutment wing walls parallel to the adjacent travel lane.

At MSE walls, use bridge ends consisting of cast-in-place reinforced concrete caps supported with piles or cast-in-place reinforced concrete drilled shafts that are set back behind the MSE wall faces as shown in SCDOT Geotechnical Drawings and Details.

The following applies to bent cap cantilevers for end bents:

- For a cap supported by prestressed concrete piles, provide a minimum of the equivalent of 2 pile widths of distance from the centerline of the exterior pile to the end of the cap.
- Do not detail the intersection of the centerlines of bent and exterior beam/girder on the bent cap cantilever.
- Provide a distance from the centerline of exterior pile to the edge of a slab superstructure, measured along the bent cap centerline, that is less than or equal to 30 percent of the average pile spacing of the bent.

### 2.1.21 Integral Bent Caps

If integral bent caps are used on this Project, construct the caps using cast-in-place concrete.

### 2.1.22 Slope Protection

Provide concrete slope protection for the end fills under new grade separation bridges. If a bridge has a vertical abutment wall, provide concrete slope protection in the area under the bridge between the wall and

the paved shoulder. Detail concrete slope protection with a minimum thickness of 4 inches and in accordance with Drawing No. 804-01 of the Bridge Drawings and Details and in accordance with the requirements of Section 804 of the Standard Specifications for Highway Construction.

#### 2.1.23 Barriers Supported by Moment Slabs

When required, provide barriers supported by moment slabs that are designed in accordance with the AASHTO LRFD Bridge Design Specifications. Detail the moment slabs independently of MSE walls as shown on Drawing No. 713-01d of the SCDOT Geotechnical Drawings and Details.

#### 2.1.24 Bridge Plans

As required by the SCDOT Bridge Design Manual, include in the bridge plans Reinforcing Steel Schedules and Quantities Tables for each bridge component (end bents, interior bents, spans, etc.). When these components are required to be constructed in stages, break the Reinforcing Steel Schedules and Quantities Tables down by stage. Immediately following the title sheet, provide a quantities sheet that includes a tabulation of estimated quantities and a summary of estimated quantities.

## 2.2 Retaining Walls

### 2.2.1 Mechanically Stabilized Earth (MSE) Walls

Design and construct MSE walls in conformance with Supplemental Technical Specification SC-M-713 and SCDOT Geotechnical Drawings and Details, Drawings No. 713-01 and 713-02.

At bridge abutments, construct MSE wall facing using precast concrete panels with a deep fractured fin finish in accordance with Standard Drawing 701-950-01.

Provide a minimum of 3 feet of clear distance between the fill face of the MSE wall panels and the piles or drilled shafts. For two staged walls (walls with both temporary and permanent faces), provide a minimum of 3 feet of clear distance between the fill face of stage 1 (temporary face) and the piles or drilled shafts.

Design wall heights and lengths to provide adequate cover for roadway and bridge drainage inlets and pipes in the roadway approaches. In addition, design wall heights and lengths to provide adequate slope transitions to maintain stable shoulders and slopes and design clearances and templates in accordance with the design criteria.

Do not use MSE wall structures, with panel type facings, that exceed heights of 40 feet. Do not use MSE wall structures, with modular block



type facings, that exceed heights of 30 feet. Do not use MSE wall structures, with modular block type facings, that are visible to interstate traffic.

Provide a concrete paved drainage ditch along the top of the wall as shown on the SCDOT Geotechnical Drawings and Details.

#### 2.2.2 Reinforced Concrete Walls

Base selection criteria for reinforced concrete walls on FHWA Publication FHWA NHI-07-071 entitled Earth Retaining Structures, 2008.

Design these walls in accordance with the AASHTO LRFD Bridge Design Specifications and FHWA Publication FHWA NHI-07-071 entitled Earth Retaining Structures, 2008.

Provide a concrete paved drainage ditch along the top of the wall if the retained soil slopes towards the back of the wall.

Spread footings are permitted for concrete retaining walls that are not directly supporting bridges.

#### 2.2.3 Other Wall Types

Other acceptable wall types include Precast Counterfort walls (which are permitted in conjunction with traditional MSE walls in partial rock cuts), Tangent Pile/Secant Pile walls, Anchored walls, Sheet Pile walls having reinforced concrete coping, Soldier Pile and Lagging walls, and Soil-Nailed walls.

Prior to commencing any designs of other wall types as specified herein, submit to SCDOT the wall type selected, design methodology, design criteria, and material and construction specifications for review. In the design criteria, include wall geometry and location, resistance factors, soil properties, and material properties of the wall. If the walls support bridge embankments, also submit conceptual bridge plans in accordance with Section 3.2 of the SCDOT Bridge Design Manual. Submit shop plans and any calculations for other wall types in accordance with Section 725 of the SCDOT 2007 Standard Specifications for Highway Construction.

Provide a concrete paved drainage ditch along the top of the wall if the retained soil slopes towards the back of the wall.

#### 2.2.4 Traffic Railing

If the face of a retaining wall is located either within the clear zone or within 30 feet of the edge of a travel lane, design the wall for a Test Level 4 impact and provide a Test Level 4 barrier with a traffic face that is a minimum of 46 inches in height, measured from top of pavement to top of

traffic face, and that has a constant 9.1 degree (1H:6.25V) slope away from traffic. This requirement applies to both sides of the wall. Except for cast-in-place concrete gravity and semi-gravity walls, barriers must be detailed independently of the wall and must be supported by a moment slab. An exception to this is that at the low side of wall only, the barrier detail described in Section 2.4.2.2, “Vertical Abutments”, may be used in lieu of the barrier supported by moment slab. For barriers adjacent to I-26 travel lanes, construct the traffic face of the barrier at an elevation that will accommodate the future widening of I-26.

#### 2.2.5 Anti-Graffiti Coating

Apply an Anti-Graffiti Coating to exposed surfaces of retaining walls.

#### 2.2.6 Plans Preparation

Include retaining wall plans within the set of roadway plans and number the sheets using an “S” prefix. However, if retaining walls are used as vertical bridge abutments, include the wall plans in the bridge plans. Include the following information in the wall construction plans:

##### 2.2.6.1 Design Information

Indicate the design parameters.

##### 2.2.6.2 Plan View

Provide a plan view that includes the following information and details:

- proposed wall location,
- centerline of roadway,
- stationing,
- stations and offsets of beginning and end of wall,
- length of wall,
- guard rail (if required),
- drainage basins/flumes,
- construction staging (if required),
- north arrow,
- existing structures, features, and utilities in vicinity of the wall if they impact construction,
- temporary shoring (if required), and
- boring locations.

##### 2.2.6.3 Elevation View

Provide an elevation view that shows the top of the wall elevations, footing elevations (when applicable), and the existing ground line.

In the elevation view, also show the final ground line along each face of the wall.

#### 2.2.6.4 Details

Include details of each wall component and requirements of the architectural or finish treatment.

#### 2.2.6.5 Cross Sections

Provide section views of the wall.

#### 2.2.6.6 Reinforcing Steel Schedule and Quantities

If the construction of the wall includes reinforcing steel, include a reinforcing steel schedule that lists the reinforcing steel required for the wall. In this schedule, include the mark, number of bars required, and dimensions for each reinforcing bar. Also, provide a table of estimated quantities for each wall. For projects requiring stage construction, break the reinforcing steel schedule and quantities down by stage.

#### 2.2.6.7 Special Details

Include details for construction of walls around buried foundations, drainage facilities, pipe penetrations, and utilities.

#### 2.2.6.8 Boring Logs

Include copies of the boring logs.

### 2.3 **Box Culverts and Box Culvert Extensions**

#### 2.3.1 Design Specifications

Design all new culverts in accordance with the requirements of the AASHTO LRFD Bridge Design Specifications. Use the HL-93 live loading.

The Contractor may design extensions of existing culverts in accordance with the Seventeenth Edition of the AASHTO Standard Specifications for Highway Bridges if the existing culvert was designed using the AASHTO Standard Specifications for Highway Bridges. If this option is selected, design for HS 20-44 Loading or an Alternate Military Loading of two axles four feet apart with each axle weighing 24,000 pounds, whichever produces the greater stress.

Hydraulically design culverts that convey water in accordance with the requirements of the SCDOT Requirements for Hydraulic Design Studies.

Perform subsurface investigations for culverts in accordance with the requirements of the SCDOT Geotechnical Design Manual.

Consider seismic effects for new culverts as required by the SCDOT Seismic Design Specifications for Highway Bridges.

### 2.3.2 Materials

Use Class 4000 concrete for cast-in-place elements of culverts and use Class 5000 concrete for precast elements of culverts.

Use reinforcing bars conforming to the requirements of ASTM A 706, Grade 60. Use Welded Wire Fabric that meets the requirements of AASHTO M 55 or AASHTO M 221.

### 2.3.3 Design and Detailing Requirements

#### 2.3.3.1 General

Culverts will not be allowed as a substitute for bridges specified in this project. Construct culverts with four sides and using reinforced concrete.

Establish the length of the culvert so that, at the end of the culvert, the theoretical fill slope is 1 foot below the top of the top slab. Locate the culvert headwalls outside of the adjusted clear zone (see SCDOT Standard Drawing No. 805-010-00) where practical or shield the exposed portions of the structure appropriately.

Detail weep holes and French drains in accordance with Section 702 of the SCDOT Standard Specifications for Highway Construction. Locate the weep holes 12 inches above the normal water line.

For culverts that convey water, detail rip rap and geotextile fabric at both ends of the culvert in accordance with SCDOT Standard Drawing No. 804-205-00.

From the beginning of construction until the end of the 75-year design life of the culvert, limit the settlement to 8 inches. Limit the maximum allowable differential settlement along the length of a culvert to 1 inch per 50 feet of culvert length. If deep foundations are used to limit the settlement of a culvert, limit the longitudinal differential settlement between the culvert and the adjacent paved embankment to a maximum of 1 inch in 20 years.

Detail additional reinforcing steel at openings in the top slab or side walls to meet or exceed the reinforcement shown on SCDOT Standard Drawing No. 722-105-02.

Detail all box culverts, whether cast-in-place or precast, with cast-in-place wing walls, head walls, aprons, and cut-off walls on both the inlet and outlet ends. Do not use precast wing walls, head walls, aprons, cut-off walls, and footings.

In situations where guardrail is required and installation of the posts conflicts with the top slab of the culvert, detail a 12'-6" long span of nested guardrail to bypass the culvert if site and culvert geometry permit. For details of this nested guardrail, see SCDOT Standard Drawing No. 805-565-00. As shown on this drawing, detail a 10:1 or flatter slope for the shoulder area and maintain a minimum 5'-6" offset between the face of the guardrail and the back of the head wall. When nested guardrail is required, include on the plans a note specifying that the guardrail installation must comply with SCDOT Standard Drawing No. 805-565-00.

If guardrail is required and site and culvert geometry do not permit the nested guardrail installation, provide a moment slab to anchor the guardrail. Design and detail the moment slab to eliminate transfer of moment to the culvert barrel. If the moment slab is attached to the culvert barrel for resistance to sliding forces, design and detail the connection to resist horizontal sliding forces only.

#### 2.3.3.2 Wing Walls

Wing walls are typically flared out approximately 30 degrees in relation to the centerline of the culvert, but the angle may vary based on site conditions. Detail the wing walls so that the top of the wing wall is at least 12 inches above the finished ground line. Design and detail the wing wall height so that, at the junction of the wing wall and culvert barrel, the top of the wing wall is the same elevation as the top of the top slab of the culvert barrel. Extend the wing wall at least to a point where the soil can wrap around the exposed face of the wing wall, using a slope of 2H:1V or flatter, without encroaching on the projected barrel opening.

Support wing walls by footings or aprons, but assume no support from the culvert barrel(s).

Detail the thickness of wing walls equal to or greater than the exterior wall thickness of the culvert. If the maximum wing wall height is greater than 5 feet and the wing wall has a layer of reinforcing in each face, provide a minimum of 5 inches of clearance between the mats of reinforcing steel.

#### 2.3.3.3 Aprons

For box culverts, detail aprons as continuously cast-in-place concrete placed from end to end of the wing walls. Aprons may cover the entire area between the wing walls and the ends of the culvert barrel(s) or may follow the edges of the wing wall/culvert barrel(s). Detail the thickness of the aprons equal to or greater than the thickness of the bottom slab unless the bottom slab thickness exceeds 12 inches. If the bottom slab thickness exceeds 12 inches, detail the apron thickness as 12 inches unless a thicker apron is required by design.

#### 2.3.3.4 Cut-off Walls

Detail cut-off walls with a minimum thickness of 10 inches. Detail cut-off walls to extend a minimum of 2 feet below the bottom of the bottom slab or apron. Detail cut-off walls to extend to a depth 2 feet below the scour depth or into unweathered rock. If cut-off walls are used as structural elements, design and detail appropriate reinforcement.

#### 2.3.3.5 Head Walls

Detail head walls with a minimum height of 12 inches above the finished ground line and a minimum thickness of 12 inches. Detail head walls to extend the full width of the culvert barrel(s).

Anchor the head walls to the top slabs of culverts with reinforcing steel that has been designed and detailed to resist overturning and sliding. Detail each face of the head wall with a minimum of 0.2 square inches of reinforcing steel per foot in each direction.

#### 2.3.3.6 Concrete Cover

For cast-in-place box culverts, provide concrete cover to reinforcing in accordance with the AASHTO LRFD Bridge Design Specifications. For W/C ratios that are less than or equal to 0.4, use a concrete cover modification factor of 1.0.

For precast box culverts in counties other than Beaufort, Berkeley, Charleston, Colleton, Dorchester, Georgetown, Horry, and Jasper, detail the clear cover as shown in ASTM C 1433 and ASTM C 1577. For precast box culverts that convey intermittent flow in Beaufort, Berkeley, Charleston, Colleton, Dorchester, Georgetown, Horry, and Jasper counties, detail the clear cover as shown in ASTM C 1433 and ASTM C 1577. For precast box culverts that convey permanent flow in Beaufort, Berkeley, Charleston,

Colleton, Dorchester, Georgetown, Horry, and Jasper counties, detail a minimum of 3 inches of clear cover for reinforcing.

#### 2.3.3.7 Existing Culverts and Extensions

Where a change in fill height is proposed for culverts remaining in place or being extended, evaluate the existing culvert to determine if it is structurally adequate to handle the revised loading conditions or if it will require total replacement.

Construct all box culvert extensions of existing cast-in-place culverts using cast-in-place concrete. Construct extensions of existing precast culverts using either precast sections or cast-in-place concrete. If precast sections are used, design and detail the extensions with a cast-in-place concrete transition between the end of the existing barrel and the first new section of precast barrel.

For extensions of existing culverts, detail adhesive anchors, #6 (#19) or greater in size, at a maximum spacing of 18 inches in the exposed ends of the existing barrel. Match the interior barrel shape of the new culvert to that of the existing culvert (i.e. chamfers, ledges, etc.) except as noted in Section [2.3.4.3](#) ~~2.4.4.3~~.

#### 2.3.4 Cast-in-Place Concrete Box Culverts

##### 2.3.4.1 General

For culverts with skews greater than 25 degrees, design and detail the transverse reinforcing steel perpendicular to the longitudinal reinforcing steel. For lesser skew angles, design and detail the transverse reinforcing steel either perpendicular or parallel to the skew.

At the discontinuous edges of culvert barrel sections, design edge beams for the top and bottom slabs.

##### 2.3.4.2 Slabs

Use a minimum thickness of 10 inches for cast-in-place box culvert top and bottom slabs.

##### 2.3.4.3 Walls

Detail cast-in-place box culvert walls vertical and detail a minimum thickness of 8 inches. If the vertical opening dimension of the culvert is greater than 5 feet, provide a minimum of 5 inches of clearance between mats of reinforcing in the walls.

For extensions of existing multi-barrel culverts having interior wall thicknesses less than the new wall thicknesses, detail a minimum 6:1 transition at the junction of the new and existing interior walls.

#### 2.3.4.4 Construction Joints

Limit the maximum pouring length of cast-in-place culvert barrel sections to 70 feet. Detail keyed transverse construction joints in the barrel(s) as required to meet this limit. Detail the longitudinal reinforcing steel continuous across the joints.

If the volume of cast-in-place concrete exceeds 225 CY in any pour, provide a pouring sequence on the plans. Complete all concrete pours in less than 5 hours. If a pouring rate greater than 45 CY/hr is needed, indicate on the plans the required pouring rate.

Detail a keyed construction joint in the walls, 4 inches above the top of the bottom slab. When the height of the wall, measured from the top of the bottom slab, is 8 feet or greater, also detail a keyed construction joint between the walls and top slab.

For construction joints located between elevations of extreme low tide and extreme high tide, include requirements on the plans for the joint to be sealed. Detail each exterior side of the joint with a ½ inch chamfer on the upper side of the joint. Specify on the plans that the Contractor seal this ½ inch chamfer with a bonding epoxy conforming to ASTM C 881, Type IV, Grade 3, and that the Contractor apply the epoxy in accordance with the manufacturer's written instructions.

#### 2.3.5 Precast Concrete Box Culverts

##### 2.3.5.1 General

Do not use precast box culvert sections if any of the following conditions exist:

- the design earth cover exceeds 20 feet,
- the design earth cover is less than 2 feet,
- the culvert is an extension of an existing cast-in-place culvert, or
- the culvert will be used for pedestrian traffic.

Use monolithically cast box culvert sections. Do not use precast concrete split box culvert sections.



### 2.3.5.2 Design Requirements

Design precast box culvert sections for new culverts in accordance with ASTM C 1577 except when clear cover for reinforcing is required to be 3 inches. Design precast box culvert sections for culvert extensions of existing precast culverts in accordance with either ASTM C 1577 or ASTM C 1433 except when clear cover for reinforcing is required to be 3 inches. For precast culverts having design fill heights greater than 5 feet, round the design fill height to the next higher 5 foot increment when using the tabulated design information from ASTM C 1577 or ASTM C 1433.

### 2.3.5.3 Detailing Requirements

Detail precast box culverts in accordance with SCDOT Standard Drawing No. 722-305-00 and Section 722 of the SCDOT Standard Specifications for Highway Construction. Require on the plans that the Contractor place all precast box culverts on a prepared bed of aggregate (Coarse Aggregate No. 5, No. 56, or No. 57) having a minimum thickness of 6 inches. Extend the aggregate bed the entire width and length of the culvert plus 3 inches beyond the outer walls of the barrel(s).

On the plans for precast box culverts, include details for cast-in-place wing walls, head walls, aprons, cut-off walls, and footings. Detail these cast-in-place elements in accordance with the requirements of Section 2.3.3. Attach these elements to the precast culvert barrel(s) using #6 (#19) adhesive anchors detailed at a maximum spacing of 18 inches in the exposed ends of the barrel(s). Design these elements as self-supporting. Use the adhesive anchors only to control differential settlement.

Where multiple precast box culvert barrels are placed side by side, the plans shall require a 3½ inch minimum and 6 inch maximum space between adjacent barrel sections. The plans shall require this space to be filled with flowable fill or cast-in-place concrete. If the space is filled with flowable fill, the plans shall require that, at both the upstream and downstream ends, the last 6 inches of space between the barrels (measured along the longitudinal direction of the barrels) be filled with a cast-in-place concrete cap for the full height of the barrels.

### 2.3.6 Plans Preparation

Include culvert plans within the set of roadway plans and number the sheets using an “S” prefix. Include the following information in the culvert plans:

2.3.6.1 Title Blocks.

In the title blocks of the culvert sheets, include the fill height used to design the culvert, the culvert opening size (span x rise), the station at centerline of culvert, and the slope of fills.

2.3.6.2 Location Sketch.

Provide a location sketch that includes the following information and details:

- proposed culvert outline,
- existing culvert outline as a light, dashed line,
- centerline of roadway,
- direction of stationing,
- station of intersection of roadway centerline and culvert centerline,
- dimensions of culvert barrels,
- length of each end of culvert measured from the roadway centerline,
- skew angle,
- construction staging (if required),
- temporary shoring locations (if required for construction),
- permissible types of temporary shoring (if restricted),
- stream name,
- direction of flow,
- limits of riprap or note that riprap in accordance with SCDOT Standard Drawing No. 804-205-00 (if required),
- north arrow,
- existing structures, features, utilities in vicinity of culvert if they impact culvert construction,
- invert elevations at each end of new culvert or both ends of each side being extended,
- boring locations, and
- hydraulic data.

2.3.6.3 Design Information.

Indicate the design specification and live load in the plans.

2.3.6.4 Plan View.

Provide a plan view that details the culvert, apron, cut-off wall, wing wall, and footing dimensions; the reinforcing bars, bar callouts, and bar spacing; and the location of any required transverse construction joints.

#### 2.3.6.5 Cross Section

Provide section views of the barrel(s), wing walls, head walls, aprons, cut-off walls, and footings detailing the dimensions; the reinforcing bars, bar callouts, and bar spacing; the weep holes and french drains; and the location of construction joints.

#### 2.3.6.6 Reinforcing Steel Schedule and Quantities

For each culvert, include a reinforcing steel schedule that lists the reinforcing steel required for the culvert. In this schedule, include the mark, number of bars required, and dimensions for each reinforcing bar. Immediately below the reinforcing steel schedule, include a list of estimated quantities for the culvert. Include all quantities required for construction of the culvert (e.g., reinforcing steel, concrete, piling, excavation, riprap, geotextile, etc.). For projects requiring stage construction, break the reinforcing steel schedule and quantities down by stage.

#### 2.3.6.7 Boring Logs

Include copies of the boring logs in the plans.

### 2.4 **Concrete Median Barriers and Bridge Pier Protection**

#### 2.4.1 Concrete Median Barrier

Slope the exposed traffic faces of concrete median barrier at a constant 9.1 degrees (1H:6.25V) away from traffic. If the exposed portion of a median barrier exceeds a height of 56 inches above the pavement, the portion of the traffic face that is higher than 56 inches may be detailed vertical or sloped away from traffic at a rate other than 1H:6.25V. Provide a 6-inch minimum top barrier width and a minimum height, measured from top of pavement to top of barrier, of 56 inches. In grade separation sections, the 56 inch minimum height may be measured from the lower pavement surface. Apply the following requirements when designing concrete median barriers:

Condition A – Concrete Median Barrier with grade separations of 18 inches or less: Use details from the SCDOT Standard Drawings. The following requirements apply to the details of Standard Drawings 805-810-01 and 805-810-02:

- Details 4, 5, & 15 – Align barrier expansion joints with rigid pavement expansion joints while maintaining the joint spacing limitations of both structures.
- All other details – Either isolate the barrier from rigid pavement by placing a bond breaker at the interface between the rigid pavement and the barrier foundation, or align expansion joints in barrier with

pavement expansion joints within the joint spacing limitations of both structures. If bond breaker is used, seal the top of the joint with a silicone sealant having a width of 3/8 inch.

Condition B – Concrete Median Barrier with grade separations between 18 inches and 36 inches: Design the barrier in accordance with AASHTO LRFD Bridge Design Specifications for a Test Level 4 impact. Reinforce the barrier wall in accordance with Chapter 7 of Midwest States' Regional Pooled Fund Research Program: Development of a TL-5 Vertical Faced Concrete Median Barrier Incorporating Head Ejection Criteria (<http://nlcs1.nlc.state.ne.us/epubs/R6000/B016.0124-2007.pdf>). Calculate and detail the minimum expansion joint spacing required for stability analysis to resist the overturning of the Test Level 4 impact force at the increased moment arm generated by the grade separation.

Condition C – Concrete Median Barrier with grade separations 36 inches and greater: In addition to the design requirements of Condition B, design the cantilever wall barrier in accordance with SCDOT seismic design requirements.

For Conditions B and C, use a transverse impact force of 54 kips for the strength design of the barrier as required by AASHTO. However, when evaluating the stability of the barrier, use a transverse force of 10 kips instead of the 54-kip load. For Conditions B and C, design and detail the barrier to provide a minimum height, measured from top of higher pavement surface to top of barrier, of 46 inches. Use a 10:1 taper to transition between Condition A barriers and Conditions B and C barriers. Design and detail the barrier foundation independent of the rigid pavement. Provide an isolating bond breaker between the rigid pavement and the barrier structure and seal the top of the joint with a silicone sealant having a width of 3/8 inch.

## 2.4.2 Bridge Protection

Provide horizontal clearances under the new overpasses in accordance with Section 2.1.5. Where applicable, detail bridge pier protection in accordance with the requirements of Sections 2.4.2.1 and 2.4.2.2.

### 2.4.2.1 Interior Bents

Detail bridge pier protection for all interior bents that are located either within the clear zone or within 30 feet of the edge of a travel lane. Use Test Level 5 details from the SCDOT Standard Drawings.

#### 2.4.2.2 Vertical Abutments

Detail bridge pier protection for the full length of all vertical abutments and vertical abutment wing walls that are located either within the clear zone or within 30 feet of the edge of a travel lane. Use Test Level 5 details from the SCDOT Standard Drawings, except modify the barrier shape and provide backfill between the barrier and wall as shown on the drawing entitled “Rigid Barrier Adjacent to Wall” in Attachment B.

### 3.0 DELIVERABLES

Prior to submittal, subject all submittals to SCDOT to a thorough QC review.

#### 3.1 Preliminary Structural Plans

Submit two half size sets and an electronic copy (in PDF format) of Preliminary Structural Plans for SCDOT’s review. Include in the Preliminary Structural Plans, at a minimum, all items described in Chapter 3 of the SCDOT Bridge Design Manual. Partial submittal of the required contents of the preliminary set of plans will not be allowed. Submit the Preliminary Geotechnical Report with the preliminary plans.

#### 3.2 Final Structural Plans

Submit two half size sets and an electronic copy (in PDF format) of Final Structural Plans for SCDOT’s review. Include in the Final Structural Plans, at a minimum, all items described in Chapter 3 of the SCDOT Bridge Design Manual. Partial submittal of the required contents of the final set of plans will not be allowed. Submit the Final Geotechnical Report with the final plans. After submitting final plans for review, advise SCDOT of all changes made to the plans that are not made to address SCDOT comments.

#### 3.3 Design Calculations

Provide an electronic copy (in PDF format) of all structural design calculations to SCDOT.

#### 3.4 Release for Construction (RFC) Plans

Provide one full size set of RFC Plans to SCDOT. Ensure RFC plan submittals to SCDOT are signed and sealed by the State of South Carolina licensed Professional Engineer of Record. Insert RFC Plans into plan covers as detailed in the SCDOT Bridge Design Manual.

#### 3.5 Shop Plans

Submit shop plans, as defined by the Standard Specifications for Highway Construction, to the Contractor’s designer for review and approval. Route all

approved shop plans to SCDOT for review and distribution. Provide shop plan submittals that meet the criteria of Subsection 725.1.1 of the Standard Specifications for Highway Construction. After reviewing the plans, SCDOT will either distribute the plans or provide comments. If comments are provided, the Contractor's designer shall review the comments prior to resubmitting to the SCDOT for further review. The Contractor's designer shall stamp the shop plans "approved" prior to submittal to SCDOT. SCDOT will stamp and distribute the plans. Do not commence fabrication and construction/erection until after SCDOT distributes the plans. The responsible engineer, registered as a Professional Engineer in the State of South Carolina, shall seal, sign, and date all design calculations and shop plans.

### **3.6 Working Drawings**

Submit working drawings and design calculations, as defined by the Standard Specifications for Highway Construction, to the Contractor's designer for review and approval. Route all approved working drawings and design calculations to the SCDOT for review and distribution. Provide working drawings and design calculation submittals that meet the criteria of Subsection 725.1.2 of the Standard Specifications for Highway Construction. SCDOT will review the drawings and calculations and either provide acceptance of the drawings as prepared or provide comments. If comments are provided, the Contractor's designer shall review the comments prior to resubmittal to SCDOT for further review. The Contractor's designer shall stamp the working drawings and design calculations "approved" prior to submittal to SCDOT. SCDOT will stamp and distribute the drawings and calculations. Do not commence construction/erection until after SCDOT distributes the drawings and calculations. The responsible engineer, registered as a Professional Engineer in the State of South Carolina, shall seal, sign, and date all design calculations and working drawings.

SCDOT will review the working drawings and design calculations only to verify that the specifications have been addressed.

# **EXHIBIT 4c**

## **PAVEMENT DESIGN CRITERIA**

## 1.0 GENERAL

Exhibit 4c contains requirements for:

- Hot Mix Asphalt (HMA) pavement and base for the new Volvo Car Boulevard
- Hot Mix Asphalt (HMA) pavement and base for I-26 Auxiliary Lanes
- Hot Mix Asphalt (HMA) pavement and base for I-26 Shoulders
- Hot Mix Asphalt (HMA) pavement and base for Interchange Ramps
- Hot Mix Asphalt (HMA) pavement and base for Interchange Ramp Shoulders
- I-26 Cross-Slope Correction
- Temporary pavement

## 2.0 CRITERIA

### 2.1 New Location and Widening

2.1.1 Construct a new HMA pavement with the following characteristics:

125 psy OGFC (only to be placed adjacent to I-26, see notes Section 2.3)  
200 psy Surface Type A  
250 psy Intermediate Type A (second lift)  
250 psy Intermediate Type A (first lift)  
450 psy Base Type A  
6 inches Graded Aggregate Base Course (GABC)

Shoulder will match mainline design. GABC to be placed as construction platform during bridge construction.

### 2.2 I-26 Cross-Slope Correction

Surface plane approximately 1.5 inches uniform to remove existing OGFC. Perform full depth patching as directed by RCE. Complete Cross-slope correction as indicated on typical section in Attachment B. Correction shall be accomplished using a combination of buildup and milling such that there is no reduction of existing pavement thickness. Use Surface Type E for correction up to 1.5 inches. Use Intermediate Type B for correction that requires greater than 1.5 inches per lift.

The final 2 lifts shall be uniform:

125 psy OGFC  
200 psy Surface Type A



**2.3 General Notes for HMA Pavements**

Prior to placing the final permanent pavement markings, all areas not requiring pavement reconstruction or rehabilitation but requiring revised temporary or permanent pavement markings shall be milled 3-inches and resurfaced utilizing 200 psy hot mix asphalt HMA Surface Type A and 125 psy OGFC on interstate pavements.

Include 1000 SY of full depth asphalt patching in accordance with the Special Provision in Exhibit 5. Full depth patching shall be conducted prior to variable build up or overlay.

Overlay all surface planed areas with at least 200 psy HMA Intermediate Type B in the same paving season the surface planing was conducted.

Carry the OGFC to a width of 4 feet over shoulders that are 4 feet or greater in width and to the full shoulder width for shoulders less than 4 feet in width. For shoulders adjacent to barrier walls, carry the OGFC to the face of the drop inlets or 4 feet, whichever is less. Carry the OGFC along the ramp to the gore, then variably mill 0 to 1 inch over a minimum of 75 feet and terminate the OGFC in a neat, smooth transverse joint.

Milled-in rumble strips shall be used on all shoulders, both inside and outside, in accordance with SCDOT Standard Drawings and specifications for the entire project.

Cross-slope verification in accordance with Exhibit 5 – Special Provisions is required for mainline interstate pavement.

HMA Surface Type B with PG76-22 may be substituted for Surface Type A in all applications.

**2.4 Temporary Pavement**

Design of temporary pavement, including using the existing shoulder to carry the mainline traffic, is at the discretion of the Contractor. However, temporary pavement must provide a satisfactory rideability to the public prior to opening to traffic and during construction. Satisfactory rideability is defined as any 0.1 mile segment having roughness not to exceed 170 inches per mile when tested in accordance with SC-T-125. In addition to rideability, rutting shall not exceed ¼” when the wheel paths are measured with a 4 foot straightedge.

EXHIBIT 4c – PAVEMENT DESIGN CRITERIA
---------------------------------------

The Contractor shall take action within one calendar day to temporarily fill the pothole for safety, if potholes appear in the temporary pavement. Once per week all temporarily filled pot holes shall be full depth patched varying in depth as necessary but shall be no less than 4 inches. Any full depth patching required on temporary pavement is not to be paid for from full depth patching quantities included in Exhibit 5.

If temporary pavement is to be incorporated in the final pavement structure, it must be free of cracks and distortion prior to overlay. If the pavement has visible wear or deterioration, then take remedial action to improve or repair the pavement to the Department's satisfaction prior to overlaying.

# **EXHIBIT 4d**

## **TRAFFIC DESIGN CRITERIA**

### **Part 1 – Signing and Pavement Marking**

**1.0 GENERAL PROVISIONS FOR PERMANENT PAVEMENT MARKINGS**

Pavement marking work on this project consists of preparing detailed pavement marking plans and applying appropriate markings for the entire length of the project including tie points to the interstate mainline, all new ramps and all new non interstate routes. All mainline and ramp edge lines and lane lines shall be to interstate standards as detailed in the Standard Drawings. The markings on all crossing routes and surface roads shall be as detailed in the Standard Drawings. For interstate ramps and Volvo Car Drive, lane lines and edge lines shall be 6 inches in width. Exit and entrance gore markings shall be 12 inches in width. For all other roads, markings shall be 4 inches in width with any channelization markings being 8 inches in width. The final roadway surface material will determine which type of permanent marking material is to be applied. The CONTRACTOR shall use either polyurea or preformed tape (T-1) markings on concrete surfaces for the applications noted below. Thermoplastic markings shall be used on all asphalt surfaces. The CONTRACTOR shall install surface mounted raised pavement markers in accordance with the Standard Drawings.

Pavement marking materials used shall meet the following requirements:

**1. THERMOPLASTIC PAVEMENT MARKINGS (ASPHALT SURFACES):**

All thermoplastic markings installed on the interstate mainline, ramps or any crossing routes shall meet the requirement of Section 627 of the Standard Specifications.

**2. POLYUREA PAVEMENT MARKINGS (CONCRETE SURFACES):**

All polyurea markings installed on the interstate mainline, ramps crossing routes or any bridge decks on this project shall be a liquid, multi-component system that includes highly reflective elements.

The polyurea pavement marking lines shall have a minimum dry thickness of 20 mils when placed on concrete and asphalt pavements. The pavement marking material and highly reflective elements shall be applied in a simultaneous operation.

The CONTRACTOR shall apply the polyurea resin, mixed at the proper ratio according to the manufacturer's recommendations, to the pavement surfaces within the proper application temperatures as determined by the material manufacturer. Highly reflective elements shall be injected into the molten (liquid) polyurea pavement markings in accordance with the manufacturer's recommendations using a dispenser approved by the manufacturers of both the polyurea materials and the highly reflective elements.

Upon curing, the markings shall be uniformly reflectorized and have the ability to resist deformation caused by traffic throughout the entire length of the line.

The manufacturer of the selected polyurea material shall provide a technical representative, or a manufacturer's certified representative, to assure proper application technique by the contractor during the initial installation of the product.

All materials will be accepted based on manufacturer's certifications.

### **3. PREFORMED PATTERNED TAPE (T-1) PAVEMENT MARKINGS (OPTION FOR CONCRETE BRIDGE DECKS):**

The CONTRACTOR may choose to apply performed patterned tape markings to concrete bridge decks on this project. If this option is selected the markings shall be preformed patterned tape with a raised diamond pattern covered with ceramic elements having a refractive index of 1.9 or greater. All preformed tape markings installed on the bridge decks on this project shall be installed with a truck mounted application system or other motorized applicator approved by the manufacturer.

The CONTRACTOR shall provide to the Department the manufacturer's normal warranty which shall guarantee the tape materials for a period of 72 months from the date of installation from failure to retain the minimum reflectance values provided by the manufacturer and from failure due to loss of material adhesion or complete wear through. If failure occurs, the manufacturer will provide the replacement materials to restore the markings to their original effectiveness.

## **2.0 GENERAL PROVISIONS FOR PERMANENT SIGNING**

Signing work on this project consists of preparing a detailed, comprehensive signing plan for the I-26 mainline, the new ramps, Volvo Car Drive and any surface roads associated with the construction of the new interchange at Exit 189. In addition, work also includes fabricating, furnishing, and erecting new ground mounted and overhead mounted signs, breakaway posts, u-channel supports, overhead sign structures and delineators. The location of the signing work is on I-26 near mile marker 189 in Berkeley County.

### **1. MAINTENANCE OF MAINLINE AND RAMP DIRECTIONAL AND INFORMATION (LOGO) SIGNING MOUNTED ON I-BEAM BREAKAWAY POSTS:**

The existing mainline and ramp directional and information signs mounted on I-beam breakaway posts may have to be relocated due to the construction. Where relocation is necessary, the mainline signs shall be mounted temporarily on 4"x6" wood posts using the method detailed on Standard Drawing 625-120-00. Ramp information signs (logo) shall be mounted temporarily on 4"x4" wood posts. All signs are to be maintained throughout construction.

In addition, the CONTRACTOR will be responsible for replacing signs damaged during construction which are to be retained (i.e. logo signs) and erected as part of the permanent signing. A Department representative shall conduct an inspection/evaluation prior to and at the conclusion of construction to determine in any damage occurred during execution of the contract.

**2. BRIDGE CLEARANCE AND CROSSING ROUTE INFORMATION SIGNING:**

The CONTRACTOR will be required to erect bridge vertical clearance and crossing route number flat sheet signs on the new bridge(s) in both directions of travel. The signs shall be fabricated in accordance with the SCDOT sign numbers shown in the table below. The CONTRACTOR shall determine the actual minimum vertical clearance in each direction after all interstate mainline or crossing route surfacing is completed.

<b>SCDOT Sign Number</b>	<b>Sign Description</b>	<b>Crossing Route Type</b>
W12-2P-78	Vertical Clearance	All
OHB M1-1-48	Crossing Route Information	Interstate – 2 or 3 digit
OHB M1-4-48	Crossing Route Information	US Route – 2 digit
OHB M1-4-60	Crossing Route Information	US Route – 3 digit
OHB M1-5-48	Crossing Route Information	SC Route – 2 digit
OHB M1-5-60	Crossing Route Information	SC Route – 3 digit
OHB M1-6-78	Crossing Route Information	Secondary Route – 2 digit
OHB M1-6-84	Crossing Route Information	Secondary Route – 3 digit

Detailed layouts for the signs in table are available from SCDOT – Director of Traffic Engineering, (803) 737-1462..

The vertical clearance sign shall be centered over the centerline of the interstate or crossing route travel way. The crossing route number sign shall be placed to the left of the vertical clearance sign with a minimum spacing of 8 feet between the right of the route number sign and the left of the clearance sign.

The flat sheet panels may be mounted on the outside beam on each side of the bridge using 3-M Very High Bond Tape in accordance with the tape manufacturer's recommendations, or other method, such as direct bolting, approved by the Engineer.

**3. SPECIAL INSTRUCTIONS TO THE CONTRACTOR:**

A conceptual signing plan is included in Attachment B of the RFP which shows the proposed sign locations and sign layouts for all overhead signs as well as all signs mounted on I-beam breakaway posts. Notes are provided on the plan for each sign location that details the sign size, sign identification numbers and a brief description of work to be accomplished. The conceptual plan does not show the location of flat sheet signs mounted on u-section posts (mile markers, warning signs, regulatory signs, etc.) along the I-26 mainline, ramps or surface roads associated with the new interchange. These signs shall be included in the comprehensive signing plan and fabricated and erected as part of this contract and shall be in compliance with the 2009 MUTCD.

The CONTRACTOR shall contact the Director of Traffic Engineering within 30 days of the issuance of the Notice to Proceed to review the conceptual signing plan and the overall signing requirements of the contract. A complete as built set of signing plans shall be submitted to the Director of Traffic Engineering at the conclusion of the project. The Director of Traffic Engineering will provide an example set of interstate signing plans to the Contractor at this meeting to use as a guide in preparation of the as built signing plans.

The CONTRACTOR is advised that SignCAD files for the all of the signs shown on the conceptual signing plan are available from the Director of Traffic Engineering. The signs are designed using SignCAD software and E Modified Highway Gothic Fonts.

Appropriate protection shall be included for all overhead uprights located within the clear zone on either side of the travel way. For guardrail installations that protect sign uprights, typically the face of the guardrail is located approximately 1 foot behind the edge of shoulder. The center of the upright shall be located approximately 9 feet behind the face of guardrail.

The CONTRACTOR will be responsible for obtaining soil borings to be used for foundation designs for all new overhead sign structures.

Walkways shall be included in the design of all new overhead structures as noted in the Standard Specifications.

The CONTRACTOR is advised that all signs have a unique barcode sticker attached to the back of each sign and each sign assembly has a unique barcode sticker attached to one post of the assembly. The CONTRACTOR will be required to record the barcode number for any sign and the associated assembly that is removed, replaced or relocated. These numbers and the date that the sign and assembly were removed, replaced or relocated shall be recorded on a form and the form shall be and turned into the Resident Construction Engineer.

The new sign bridge structure at approximate I-26 centerline station 4335+00 shall be designed to accommodate a future pull thru sign with three down arrows as noted on the conceptual signing plan.



# **EXHIBIT 4d**

## **TRAFFIC DESIGN CRITERIA**

### **Part 2 – Work Zone Traffic Control**

## 1.0 GENERAL

The Contractor shall execute the item of Traffic Control as required by the Standard Specifications, the Standard Drawings, the Special Provisions, all Supplemental Specifications, the SCDOT Procedures and Guidelines for Work Zone Traffic Control Design, the MUTCD, the Plans, and the Engineer. This is an amendment to the Standard Specifications to require the following:

## 2.0 CRITERIA

### 2.1 GENERAL REGULATIONS

These special provisions shall have priority to the plans and comply with the requirements of the MUTCD and the standard specifications. Revisions to the traffic control plan through modifications of the special provisions and the plans shall require approval by the Department. Final acceptance of any revisions to the traffic control plan shall be pending upon review by the member of the Design-Build team representing the Director of Traffic Engineering through the Design-Review Process.

In accordance with the document, *Rule on Work Zone Safety and Mobility: Implementation, Maintenance, and Safety Guidelines*, this project has been classified as “SIGNIFICANT” and all components of the Transportation Management Plan prepared by the CONTRACTOR are required and shall be implemented.

Install and utilize changeable message signs in all lane closures installed on high volume high-speed multilane roadways. Use of changeable message signs in lane closures installed on low volume low speed multilane roadways is optional unless otherwise directed by the plans and the Engineer. Install and use a changeable message sign within a lane closure set-up as directed by the *Standard Drawings*. When a lane closure is not present for any time to exceed 24 hours, remove the changeable message sign from the roadway. Place the sign in a predetermined area on the project site, as approved by the Engineer, where the sign is not visible to passing motorists. Utilize preprogrammed messages in accordance with the *Standard Drawings* when using the changeable message sign as part of the traffic control set-up for lane closures. Only those messages pertinent to the requirements of the traffic control situation and the traffic conditions are permitted for display on a changeable message sign at all times. At no time will the messages displayed on a changeable message sign duplicate the legends on the permanent construction signs.

During operation of changeable message signs, place the changeable message sign on the shoulder of the roadway no closer than 6 feet between the sign and the near edge of the adjacent travel lane. When the sign location is within 30’ of the near edge of a travel lane open to traffic, supplement the sign location with no less than 5 portable plastic drums placed between the sign and the adjacent travel lane

for delineation of the sign location. Install and maintain the drums no closer than 3 feet from the near edge of the adjacent travel lane. This requirement for delineation of the sign location shall apply during all times the sign location is within 30 feet of the near edge of a travel lane open to traffic, including times of operation and non-operation. Oversized cones are prohibited as a substitute for the portable plastic drums during this application.

All signs mounted on portable sign supports shall have a minimum mounting height of 5 feet from the bottom of the sign to the ground. All signs mounted on ground mounted u-channel posts or square steel tube posts shall have a minimum mounting height of 7 feet from the bottom of the sign to the grade elevation of the near edge of the adjacent travel lane or sidewalk when a sidewalk is present.

On multilane primary routes, avoid placement of signs on portable signs supports within paved median areas utilized for two-way left turns unless otherwise directed by the RCE.

Temporary “Exit” signs (M1025-00) shall be located within each temporary gore during lane closures on multilane roadways. Mount these signs a minimum of 7’ from the pavement surface to the bottom of the sign in accordance with the requirements of the MUTCD.

When mounting signs on ground mounted u-section or square steel tube posts, utilize either a sign support / ground support post combination with an approved breakaway assembly or a single direct driven post for each individual sign support of a sign assembly installation. Do not combine a sign support / ground support post combination and a direct driven post on the same sign assembly installation that contains two or more sign supports. Regarding sign support / ground support post combination installations, ensure that post lengths, stub heights and breakaway assemblies comply with the manufacturer’s requirements and specifications. Use approved breakaway assemblies found on the *Approved Products List For Traffic Control Devices in Work Zones*.

When covering signs with opaque materials, the Department prohibits attaching a covering material to the face of the sign with tape or a similar product or any method that will leave a residue on the retroreflective sheeting. Residue from tape or similar products, as well as many methods utilized to remove such residue, damages the effective reflectivity of the sign. Therefore, contact of tape or a similar product with the retroreflective sheeting will require replacement of the sign. Cost for replacement of a sign damaged by improper covering methods will be considered incidental to providing and maintaining the sign; no additional payment will be made.

Overlays are prohibited on all rigid construction signs. The legends and borders on all rigid construction signs shall be either reversed screened or direct applied.

Signs not illustrated on the typical traffic control standard drawings designated for permanent construction signs shall be considered temporary and shall be included in the lump sum price bid item for “Traffic Control” unless otherwise specified.

Install “Grooved Pavement” signs (W8-15-48) supplemented with the “Motorcycle” plaque (W8-15P-30) in advance of milled or surface planed pavement surfaces. On primary routes, install these signs no further than 500 feet in advance of the beginning of the pavement condition. On interstate routes, install these signs no less than 500 feet in advance of the beginning of the pavement condition. Install two sign assemblies at each sign location, one on each side of the roadway, on multilane roadways when the pavement condition is present. Install these signs immediately upon creation of this pavement condition and maintain these signs until this pavement condition is eliminated.

Install “Steel Plate Ahead” signs (W8-24-48) in advance of an area of roadway where temporary steel plates are present. Install these signs no further than 300 feet in advance of locations where steel plates are present. On multilane roadways, comply with the same guidelines as applied to all other advance warning signs and install two sign assemblies at each sign location, one on each side of the roadway, when roadway conditions warrant. Install these signs immediately upon installation of a temporary steel plate and maintain the signs until the temporary steel plates are removed.

Install and maintain any necessary detour signing as specified by the typical traffic control standard drawings designated for detour signing, Part VI of the MUTCD, these Special Provisions, and the Engineer. The lump sum price bid item for “Traffic Control” includes payment for installation and maintenance of the detour signing.

The Contractor shall maintain the travel patterns as directed by the traffic control plans and shall execute construction schedules expeditiously. The Contractor shall provide the Resident Engineer with no less than a two-week prior notification of changes in traffic patterns.

During nighttime flagging operations, flaggers shall wear a safety vest and safety pants that comply with the requirements of ANSI / ISEA 107 standard performance for Class 3 risk exposure, latest revision, and a fluorescent hard hat. The safety vest and the safety pants shall be retroreflectorized and the color of the background material of the safety vest and safety pants shall be fluorescent orange-red or fluorescent yellow-green.

During nighttime flagging operations, the contractor shall illuminate each flagger station with any combination of portable lights, standard electric lights, existing street lights, etc., that will provide a minimum illumination level of 108 Lx or 10 fc.

During nighttime flagging operations, supplement the array of advance warning signs with a changeable message sign for each approach. These changeable message signs are not required during daytime flagging operations. Install the changeable message signs 500 feet in advance of the advance warning sign arrays. Messages should be “Flagger Ahead” and “Prepare To Stop”.

During surface planing and milling operations, grade elevation differences greater than 1 inch in areas with pavements composed of hot mixed asphalt (HMA) base courses, intermediate courses or surface courses and Portland cement concrete are PROHIBITED unless otherwise directed by the Department. However, during surface planing and milling operations for removal of Open-Graded Friction courses ONLY, a grade elevation difference of 1½ inches between adjacent travel lanes opened to traffic may exist unless otherwise directed by the Department.

During the paving operations, the length of roadway with an acceptable grade elevation difference less than or equal to 2" shall be restricted to 4 miles.

During the milling and surface planing operations, the length of roadway with an acceptable grade elevation difference less than or equal to 1" shall be restricted to 4 miles.

During construction on the ramps, the contractor shall conduct flagging operations. The flagging operations shall either stop traffic or direct the traffic around the work area. Installation and operation of these flagging operations shall be according to these special provisions and the MUTCD.

Supplement and delineate the shoulder edges of travel lanes through work zones with traffic control devices to provide motorists with a clear and positive travel path. Utilize portable plastic drums unless otherwise directed by the Department. Vertical panels may be used where specified by the plans and directed by the RCE. The installation of traffic control devices are required in all areas where those areas immediately adjacent to a travel lane open to traffic have been altered in any manner by work activities, including but not limited to activities such as grading, milling, etc. Install the traffic control devices immediately upon initiating any alterations to the areas immediately adjacent to or within 15 feet of the near edge line of the adjacent travel lane. When sufficient space is available, place the traffic control devices no closer than 3 feet from the near edge of the traffic control device to the near edge line on the adjacent travel lane. When sufficient space is unavailable, place the traffic control device at the maximum distance from the near edge of the adjacent travel lane available.

## 2.2 LANE CLOSURE RESTRICTIONS

The lane closure restrictions stated below are project specific, for all other restrictions, see supplemental specification, “Restrictions”, dated September 1, 2015.

**Primary and Secondary Routes –**

On primary and secondary routes, the Department prohibits lane closures during any time of the day that traffic volumes exceed 800 vehicles per hour per direction. The Department reserves the right to suspend a lane closure if any resulting traffic backups are deemed excessive by the Engineer. Maintain all lane closure restrictions as directed by the plans, these special provisions, and the Engineer.

**Interstate Routes -**

**Single Lane Closures –**

On Interstate 26, the Department prohibits lane closures on eastbound I-26 Monday from 6:00 am to 6:00 pm, Tuesday from 8:00 am to 6:00 pm, Wednesday through Thursday from 7:00 am to 7:00 pm, Friday from 8:00 am to 9:00 pm, Saturday from 10:00 am to 7:00 pm and Sunday from 12:00 pm (Noon) to 9:00 pm. The Department prohibits lane closures on westbound I-26 Monday from 7:00 am to 6:00 pm, Tuesday through Thursday from 8:00 am to 7:00 pm, Friday from 8:00 am to 8:00 pm, Saturday from 7:00 am to 6:00 pm, and Sunday from 9:00 am to 8:00 pm.

<b>Hourly Lane Closure Prohibitions</b>	
<b>Eastbound</b>	<b>Westbound</b>
MON: 6A-6P	MON: 7A-6P
TUE: 8A-6P	TUES-THU: 8A-7P
WED-THU: 7A-7P	FRI: 8A-8P
FRI: 8A-9P	SAT: 7A-6P
SAT: 10A-7P	SUN: 9A-8P
SUN: 12P (Noon)-9P	

All other routes with lane closure prohibitions for this project are listed on the SCDOT website under Doing Business with SCDOT in the Publications and Manuals section for Traffic Engineering.

These restrictions also apply to all road closures and pacing operations. The Department reserves the right to suspend a lane closure if any resulting traffic backups are deemed excessive by the Engineer. Maintain all lane closure restrictions as directed by the plans, these special provisions, and the Engineer.

Installation and maintenance of a lane closure is PROHIBITED when the Contractor is not actively engaged in work activities specific to the location of the lane closure unless otherwise specified and approved by the Engineer. The length of the lane closure shall not exceed the length of roadway anticipated to be subjected to the proposed work activities within the work shift time frame or the maximum lane closure length specified unless otherwise approved by the Engineer. Also, the maximum lane closure length specified does not warrant installation of the specified lane closure length when the length of the lane closure necessary for conducting the work activity is less. The length and duration of each lane closure, within the specified parameters, shall require approval by the Engineer prior to installation. The length and duration of each lane closure may be reduced by the Engineer if the work zone impacts generated by a lane closure are deemed excessive or unnecessary.

On multilane primary and secondary routes, a reduced regulatory speed limit of 35 MPH shall be in effect during lane closures. Erect temporary regulatory “Speed Limit” signs (R2-1-48-35) and “Speed Reduction 35 MPH” signs (W3-5-48-35) on temporary supports according to the typical traffic control standard drawings. Cover the existing regulatory speed limit signs when reduced speed limits are in place. Immediately remove or cover the “Speed Limit” signs (R2-1-48-35) and the “Speed Reduction 35 MPH” signs (W3-5-48-35) upon the removal of the lane closures.

On interstate routes, a reduced regulatory speed limit of 45 MPH shall be in effect during lane closures. Erect temporary regulatory “Speed Limit” signs (R2-1-48-45) and “Speed Reduction 45 MPH” signs (W3-5-48-45) on temporary supports according to the typical traffic control standard drawings. Cover the existing regulatory speed limit signs when reduced speed limits are in place. Immediately remove or cover the “Speed Limit” signs (R2-1-48-45) and the “Speed Reduction 45 MPH” signs (W3-5-48-45) upon the removal of the lane closures.

On interstate routes, the presence of temporary signs, portable sign supports, traffic control devices, trailer mounted equipment, truck mounted equipment, vehicles and vehicles with trailers relative to the installation or removal of a closure and personnel are prohibited within 30 foot clear zone during the prohibitive hours for lane closures specified by these special provisions.

Truck mounted changeable message signs shall be required during all interstate lane closures. The Contractor shall provide, install, and maintain these signs in accordance with all requirements of the Standard Specifications for Highway

Construction (latest edition) and the typical traffic control standard drawings designated for interstate lane closures.

The truck mounted changeable message signs are in addition to the requirements for trailer mounted changeable message signs. Truck mounted changeable message signs and trailer mounted changeable message signs are not interchangeable.

The Contractor shall discontinue and remove a lane closure when the work activities requiring the presence of the lane closure are completed or are discontinued or disrupted for any period of time to exceed 60 minutes unless the presence of unacceptable grade elevation differences greater than 1inch in milled areas or greater than 2inches in all other areas are present unless otherwise directed by the Engineer.

### 2.3 SHOULDER CLOSURE RESTRICTIONS:

#### **Primary and Secondary Routes –**

On primary and secondary routes, the Department prohibits the Contractor from conducting work within 15 feet of the near edge of the adjacent travel lane on an outside shoulder or a median area under a shoulder closure during any time of the day that traffic volumes exceed 800 vehicles per hour per direction. The hourly restrictions for lane closures shall also apply to work activities conducted under a shoulder closure within 15 feet of the near edge of an adjacent travel lane or a median area. The Department reserves the right to suspend work conducted under a shoulder closure if any traffic backups develop and are deemed excessive by the Engineer. Maintain all shoulder closure restrictions as directed by the plans, these special provisions, and the Engineer.

On primary and secondary roadways, the Department prohibits the Contractor from conducting work within 1 foot or less of the near edge of an adjacent travel lane under a shoulder closure. All work that may require the presence of personnel, tools, equipment, materials, vehicles, etc., within 1 foot of the near edge of an adjacent travel lane shall be conducted under a lane closure.

#### **Interstate Routes -**

On Interstate 26, the Department prohibits the Contractor from conducting work within 15 feet of the near edge of the adjacent travel lane on the outside shoulders or the median areas of eastbound I-26 Monday from 6:00 am to 6:00 pm, Tuesday from 8:00 am to 6:00 pm, Wednesday through Thursday from 7:00 am to 7:00



pm, Friday from 8:00 am to 9:00 pm, Saturday from 10:00 am to 7:00 pm and Sunday from 12:00 pm (Noon) to 9:00 pm. The Department prohibits the Contractor from conducting work within 15 feet of the near edge of the adjacent travel lane on the outside shoulders or the median areas of westbound I-26 Monday from 7:00 am to 6:00 pm, Tuesday through Thursday from 8:00 am to 7:00 pm, Friday from 8:00 am to 8:00 pm, Saturday from 7:00 am to 6:00 pm, and Sunday from 9:00 am to 8:00 pm.

The hourly restrictions for lane closures shall also apply to work activities conducted under a shoulder closure within 15 feet of the near edge of an adjacent travel lane or a median area. The Department reserves the right to suspend work conducted under a shoulder closure if any traffic backups develop and are deemed excessive by the Engineer. Maintain all shoulder closure restrictions as directed by the plans, these special provisions, and the Engineer.

On interstate highways, the Department prohibits the Contractor from conducting work within the limits of a paved shoulder or within 10 feet of the near edge of an adjacent travel lane under a shoulder closure. All work that may require the presence of personnel, tools, equipment, materials, vehicles, etc., within the limits of a paved shoulder or within 10 feet of the near edge of an adjacent travel lane shall be conducted under a lane closure.

The Contractor shall install all shoulder closures as directed by the typical traffic control standard drawings designated for shoulder closures, and the Engineer. Substitution of the portable plastic drums with oversized cones during nighttime shoulder closures is PROHIBITED.

## 2.4 MOBILE OPERATIONS

A mobile operation moves continuously at all times at speeds of 3 mph or greater without any stops. The minimal traffic flow impacts generated by these operations involve brief traffic flow speed reductions and travel path diversions. Conduct work operations that cannot be performed at speeds of 3 mph or greater under standard stationary lane closures.

The distance intervals between the vehicles, as indicated in the *Standard Drawings*, may require adjustments to compensate for sight distance obstructions created by hills and curves and any other conditions that may obstruct the sight distance between the vehicles. However, adjustments to the distance intervals between the vehicles should be maintained within the range of variable distance intervals indicated in the standard drawings unless otherwise directed by the Engineer.

Maintain two-way radio communication between all vehicles in the vehicle train operating in a mobile operation.

Supplement the work vehicles and the shadow vehicles with amber colored flashing dome lights. The vehicles may also be supplemented with advance warning arrow panels and truck mounted attenuators as directed in the *Standard Drawings* and the Standard Specifications.

The Contractor shall install, operate and maintain all advance warning arrow panels, truck mounted attenuators and truck mounted changeable message signs as required by these special provisions, the manufacturer's specifications, the *Standard Drawings*, the Standard Specifications, the plans and the Engineer.

## **2.5 TYPICAL TRAFFIC CONTROL STANDARD DRAWINGS:**

The typical traffic control standard drawings of the "Standard Drawings", although compliant with the MUTCD, shall take precedence over the MUTCD. The typical traffic control standard drawings of the "Standard Drawings" shall apply to all projects let to contract.

Install the permanent construction signs as shown on the typical traffic control standard drawings designated for permanent construction signing.

## **2.6 ADDENDUMS**

(Addendums to the "2007 Standard Specifications for Highway Construction")

### **2.6.1 Construction (Sub-section 601.4) –**

#### Sub-section 601.4.2 Construction Vehicles (paragraph 2) -

When working within the rights-of-way of access-controlled roadways such as Interstate highways, the Contractor's vehicles may only change direction of travel at interchanges. These vehicles are prohibited from crossing the roadway from right side to the median or vice versa. Use a flagger to control the Contractor's vehicles when these vehicles attempt to enter the roadway from a closed lane or the median area. Ensure the flagger does not stop roadway traffic, cause roadway traffic to change lanes, or affect roadway traffic in any manner. The Contractor's vehicles may not disrupt the normal flow of roadway traffic or enter the travel lane of the roadway until a sufficient gap is present.

The Contractor shall have flaggers available to control all construction vehicles entering or crossing the travel lanes of secondary and primary routes. The RCE shall determine the necessity of these flaggers for control of these construction vehicles. The RCE shall consider sight distance, vertical and horizontal curves of the roadway, prevailing speeds of roadway traffic, frequency of construction vehicles entering or crossing the roadway and other site conditions that may impact the safety of the

workers and motorists when determining the necessity of these flaggers. Ensure these flaggers do not stop roadway traffic, cause roadway traffic to change lanes or affect roadway traffic in any manner. The Contractor's vehicles may not disrupt the normal flow of roadway traffic or enter the travel lane of the roadway until a sufficient gap is present.

When working within the rights-of-way of access-controlled roadways with posted regulatory speed limits of 55 MPH or greater and average daily traffic volumes {ADT} of 10,000 vehicles per day or greater, i.e. Interstate highways, all construction and work vehicles possessing any one or more of the vehicular characteristics listed below are only permitted to enter and exit a right or left shoulder work area during the presence of active lane closures unless otherwise directed by the RCE. These vehicles are not permitted to enter or exit these work areas without the presence of active lane closures unless otherwise directed by the RCE. Shoulder closures are unacceptable and insufficient methods for control of traffic at ingress / egress areas for these vehicles. The restrictive vehicular characteristics include the following:

- Over six (6) tires
- Tandem rear axles
- A base curb weight greater than 8000 lbs.
- A gross vehicular weight greater than 12000 lbs. unless performing duties as a shadow vehicle while supporting a truck mounted attenuator
- A trailer in tow except under the following conditions:
  - Trailers transporting traffic control devices (including but not limited to standard and 42" oversized traffic cones, portable plastic drums, signs, portable sign supports, u-channel and square steel tube sign posts) relative to the installation of lane closures, shoulder closures or other traffic control operations approved by the RCE
  - Trailer mounted traffic control devices (including but not limited to advance warning arrow panels, changeable message signs, temporary traffic signals, highway advisory radios, work zone intelligent transportation systems and trailer towed truck mounted attenuators)

## **2.6.2 Construction (Sub-section 601.4) –**

Sub-section 601.4.2 Construction Vehicles -

Auxiliary Warning Lights for Vehicles and Equipment -

Supplement all construction and/or construction-related vehicles and equipment that operate in a stationary or mobile work zone within or adjacent to a roadway within the highway rights-of-way with AMBER or YELLOW colored high intensity rotating or strobe type flashing auxiliary warning light devices. Utilize, install, operate and maintain a single or multiple lighting devices as necessary to provide visibility to approaching motorists.

All auxiliary warning light models shall meet *Society of Automotive Engineers* (SAE) Class I standards and SAE Standard J575 relative to *Tests for Motor Vehicle Lighting Devices and Components* and these specifications.

The amber/yellow color of the dome/lens of an auxiliary warning light device shall meet SAE Standard J578 for amber/yellow color specifications.

Auxiliary warning lights with parabolic reflectors that rotate shall rotate around a halogen lamp at a rate to produce approximately 175 flashes per minute. The parabolic reflector shall produce a minimum 80,000 candle power and a minimum 54,000 candela through an SAE Standard J846 approved amber dome.

Equip strobe type flashing auxiliary warning light devices with photosensitive circuit controls to adjust the lighting intensity in response to changes in ambient light conditions such as from day to night. These lights shall have a double-flash capability rated at approximately 80 double flashes per minute and produce a minimum 24 joules of flash energy at the highest power level setting.

Acceptable auxiliary warning light models shall provide sufficient light output to be clearly recognizable at a minimum distance of 1750 feet.

Mount all auxiliary warning light devices intended to function as the auxiliary warning light system or as an element thereof on vehicles and equipment at locations no less than 3 feet above the ground and in conspicuous locations to provide visibility to approaching motorists.

Auxiliary warning light devices and/or models that mount in the locations of the standard vehicle lighting system are unacceptable as the specified auxiliary warning light system due to restrictive simultaneous visibility capabilities from multiple sight angles. However, auxiliary warning light devices that mount in the standard vehicle lighting system locations are acceptable as supplements to the specified lighting devices mounted in locations that do meet the minimum height requirements and provide simultaneous visibility capabilities from multiple sight angles.

Standard vehicle hazard warning lights are only permitted as supplements to the specified auxiliary warning light devices.

### **2.6.3 Category I Traffic Control Devices (Section 603) –**

#### **Sub-section 603.2.2 Oversized Traffic Cones (paragraph 6) -**

Reflectorize each oversized traffic cone with 4 retroreflective bands: 2 orange and 2 white retroreflective bands. Alternate the orange and white retroreflective bands, with the top band always being orange. Make each retroreflective band not less than 6 inches wide. Utilize Type III – Microprismatic retroreflective sheeting for retroreflectorization on all projects let to contract after May 1, 2010 unless otherwise specified. Separate each retroreflective band with not more than a 2-inch non-reflectorized area. Do not splice the retroreflective sheeting to create the 6-inch retroreflective bands. Apply the retroreflective sheeting directly to the cone surface. Do not apply the retroreflective sheeting over a pre-existing layer of retroreflective sheeting.

#### **Sub-section 603.2.3 Portable Plastic Drums (paragraph 3) -**

Reflectorize each drum with Type III – Microprismatic retroreflective sheeting: 2 orange and 2 white retroreflective bands, 6 inches wide on all projects let to contract after May 1, 2010 unless otherwise specified. Alternate the orange and white retroreflective bands with the top band always being orange. Ensure that any non-reflectorized area between the orange and white retroreflective bands does not exceed 2 inches. Do not splice the retroreflective sheeting to create the 6-inch retroreflective bands. Apply the retroreflective sheeting directly to the drum surface. Do not apply the retroreflective sheeting over a pre-existing layer of retroreflective sheeting.

### **2.6.4 Category II Traffic Control Devices (Section 604) –**

#### **Sub-section 604.2.1 Type I and Type II Barricades (paragraph 3) -**

Reflectorize these barricades with Type VIII or IX Prismatic retroreflective sheeting on all projects let to contract after May 1, 2012 unless otherwise specified. Ensure that the retroreflective sheeting has alternate orange and white stripes sloping downward at a 45-degree angle in the direction of passing traffic. The stripes shall be 6 inches wide.

#### **Sub-section 604.2.2 Type III Barricades (paragraph 3) -**

Reflectorize these barricades with Type VIII or IX Prismatic retroreflective sheeting on all projects let to contract after May 1, 2012 unless otherwise specified. Ensure that the retroreflective sheeting has alternate orange and white stripes sloping downward at a 45-degree angle. Apply the sloping orange and white stripes in accordance with the requirements of the Plans, SCDOT Standard Drawings and the MUTCD. The stripes shall be 6 inches wide.

#### **2.6.5 Temporary Concrete Barrier (Sub-section 605.2.3.2) –**

##### Sub-section 605.2.3.2 Temporary Concrete Barrier (paragraph 6) -

Previously used temporary concrete barrier walls are subject to inspection and approval by the RCE before use. Ensure that previously used temporary concrete barrier walls are in good condition. Defects to a temporary concrete barrier wall that may disqualify a section of wall for use include gouges, cracks, chipped, or spalled areas. A defect that exposes reinforcing steel warrants immediate disqualification. A disqualification grade type defect shall consist of measurements in excess of 1 inch, entirely or partially within the boundaries of the end connection areas and the drainage slot areas as illustrated in the “Standard Drawings for Road Construction”, and/or in excess of 4 inches for all areas beyond the end connection areas. To warrant disqualification, these measurements shall exceed the specified dimensions in all three directions, width, height, and depth. A defect that exceeds the specified dimensions in only one or two of the three directions does not warrant disqualification.

Temporary concrete barrier walls with defects less than 6 inches in all three directions, width, height, and depth that do not expose reinforcing steel may be repaired in accordance with the following requirements. Repair is prohibited on temporary concrete barrier walls with defects 6 inches or greater in all three directions, width, height, and depth.

For repair of temporary concrete barrier walls with defects less than 6 inches in all three directions, width, height, and depth that do not expose reinforcing steel, repair the defect with a premanufactured patching material specifically fabricated for patching structural concrete. The strength of the patch must meet or exceed the design strength of the class 3000 concrete of the temporary concrete barrier wall. Perform the repair procedures in accordance with all requirements and instructions from the manufacturer of the patch material. Use a bonding compound between the patch material and the concrete unless specifically stated by the manufacturer that a bonding compound is not required. If the manufacturer states that application of a bonding compound is optional, SCDOT requires application of a bonding compound compatible with the patch material. If cracking occurs within the patched area, remove the

patch material completely and repeat the repair process. The contractor shall submit documentation stating all repairs have been conducted in accordance with these requirements prior to installing any temporary concrete barrier walls with repairs. Utilization of temporary concrete barrier walls with repairs shall require approval by the RCE prior to installation.

The Contractor shall submit certification documents for the patch material utilized for repairs to the Engineer prior to placing temporary concrete barrier walls that have been repaired on the project site.

\*\*\* *(Effective on all projects let to contract after January 1, 2017)* \*\*\*

Sub-section 605.2.3.2 Temporary Concrete Barrier (paragraph 5) -

In regard to projects let to contract after January 1, 2017, ALL *NCHRP Report 350* compliant temporary concrete barrier walls placed on a project site SHALL comply with the requirements for the recessed approval stamp as directed by the *SCDOT Standard Drawings*. Those *NCHRP Report 350* compliant temporary concrete barrier walls with the original recessed approval stamp that reads "SCDOT 350" will continue to be acceptable on projects let to contract after January 1, 2017. However, those temporary concrete barriers with the "SCDOT 350" identification plate attached to the side of the barrier walls with mechanical anchors previously grandfathered will no longer be acceptable on projects let to contract after January 1, 2017.

**2.6.6 Construction Signs (Sub-section 605.4.1.1) –**

\*\*\* *(Effective on all projects let to contract after January 1, 2016)* \*\*\*

On all projects relative to **interstate highways** let to contract after January 1, 2016, all signs attached to portable sign supports on and/or adjacent to **interstate highways** shall be rigid. Fabricate each of these rigid signs from an approved aluminum laminate composite rigid sign substrate approved by the Department. Utilization of signs fabricated from roll-up fabric substrates attached to portable sign supports installed on and/or adjacent to **interstate highways** will no longer be acceptable on projects.

ONLY those portable sign supports specified and approved for support of rigid signs fabricated from approved aluminum laminated composite rigid sign substrates and included on the *Approved Products List for Traffic Control Devices in Work Zones*, latest edition, are acceptable. To

facilitate location of acceptable portable sign supports, the listing of portable sign supports is now separated into two (2) sections; “Portable Sign Supports for Use with Roll-Up Signs ONLY” and “Portable Sign Supports for Use with Roll-Up Sign Substrates and Rigid Sign Substrates”.

**The trade names of the approved aluminum laminate composite rigid sign substrates are “Acopan”, “Alpolic”, “Dibond” and “Reynolite”. These rigid sign substrates are restricted to thicknesses no greater than 2 millimeters.**

Rigid signs fabricated from standard aluminum sign blanks or any other rigid material other than Acopan, Alpolic, Dibond or Reynolite are PROHIBITED for attachment to portable sign supports. However, rigid signs fabricated from standard 0.080 and 0.100 inches thick aluminum sign blanks will continue to be acceptable for mounting on ground mounted sign supports.

Signs fabricated from roll-up fabric substrates approved by the Department will continue to be acceptable for use on and/or adjacent to secondary and primary roadways unless otherwise directed by the Department.

The minimum mounting height of signs mounted on these portable sign supports shall continue to be 5 feet from the ground to the bottom edge of the sign except where a minimum 7 foot mounting height is required in accordance with the standard specifications, the standard drawings, these special provisions and the MUTCD, latest edition.

#### **2.6.7 Truck-Mounted Attenuator (Sub-section 605.4.2.2) –**

##### **Sub-section 605.2.2.2.3.3 Color (paragraph 1) -**

Use industrial grade enamel paint for cover of the metal aspects of the unit. Provide and attach supplemental striping to the rear face of the unit with a minimum Type III high intensity retroreflective sheeting unless otherwise directed by the Department. Utilize an alternating 4 to 8 inch black and 4 to 8 inch yellow 45-degree striping pattern that forms an inverted “V” at the center of the unit that slopes down and to the sides of the unit in both directions from the center.



**2.6.8 Truck-Mounted Attenuator (Sub-section 605.4.2.2) –****Sub-section 605.4.2.2 Truck-Mounted Attenuators (paragraph 6) -**

A direct truck mounted truck mounted attenuator is mounted and attached to brackets or similar devices connected to the frame of a truck with a minimum gross vehicular weight (GVW) of 15,000 pounds (actual weight) unless otherwise directed. A trailer towed truck mounted attenuator is towed from behind and attached via a standard pintle hook / hitch to the frame of a truck with a minimum gross vehicular weight (GVW) of 10,000 pounds (actual weight) unless otherwise directed.

Each truck utilized with a truck mounted attenuator shall comply with the manufacturer's requirements to ensure proper operation of the attenuator. The minimum gross vehicular weight (GVW) (actual weight) for each truck shall comply with these specifications unless otherwise directed within the "Remarks" column of the *Approved Products List For Traffic Control Devices in Work Zones* in regard to specific requirements for the device in question.

If the addition of supplemental weight to the vehicle as ballast is necessary, contain the material within a structure constructed of steel. Construct this steel structure to have a minimum of four sides and a bottom to contain the ballast material in its entirety. A top is optional. Bolt this structure to the frame of the truck. Utilize a sufficient number of fasteners for attachment of the steel structure to the frame of the truck to ensure the structure will not part from the frame of the truck during an impact upon the attached truck mounted attenuator. Utilize either dry loose sand or steel reinforced concrete for ballast material within the steel structure to achieve the necessary weight. The ballast material shall remain contained within the confines of the steel structure in its entirety and shall not protrude from the steel structure in any manner.

**2.6.9 Trailer-Mounted Changeable Message Signs (Sub-section 606.3.2) -****Sub-section 606.3.2.7 Controller (paragraphs 1-4) -**

The controller shall be an electronic unit housed in a weatherproof, rust resistant box with a keyed lock and a light for night operation. Provide the unit with a jack that allows direct communications between the on-board controller and a compatible personal computer. The unit shall have a LCD display screen that allows the operator to review messages prior to displaying the message on the sign.

The controller shall have the capability to store 199 factory preprogrammed messages and up to 199 additional messages created by the user in a manner that does not require a battery to recall the messages. Also, the controller shall allow the operator the capability to program the system to display multiple messages in sequence.

Provide the controller with a selector switch to allow the operator to control the brightness or intensity level of the light source of the sign panel. The selector switch shall include "bright," "dim" and "automatic" modes; inclusion of additional modes is permissible. When the selector switch is in the "automatic" mode, a photosensitive circuit shall control the brightness or intensity level of the light source in response to changes in ambient light such as from day to night and other various sources of ambient light.

Equip each sign with remote communications capabilities, such as utilization of cellular telephone or internet browser technology, to allow the operator to revise or modify the message selection from the office or other remote location. Also, provide protection to prohibit unauthorized access to the controller, (i.e. password protection).

The Contractor shall provide, install, operate, and maintain the trailer-mounted changeable message sign per traffic control set-up as directed by the Plans, the "Standard Drawings for Road Construction", these Special Provisions, the Specifications, and the Engineer.

#### **2.6.10 Temporary Pavement Markings (Sub-section 609.4.1) –**

Sub-section 609.4.1.1.1 Application Requirements General (in addition to paragraph 3) -

On two-lane two-way roadways, apply and place temporary or permanent pavement markings, as specified hereupon, prior to the end of each day's work or shift or reopening a closed travel lane to traffic. These pavement markings shall include 4-inch wide solid lines on edge lines and solid center lines and 4-inch wide by 10 feet long broken lines with a 30-foot gap for broken center lines and lane lines unless otherwise specified. The center line pavement markings shall be either double yellow solid lines, yellow broken lines or an appropriate combination of a yellow solid line and yellow broken lines for passing / no passing zones. Placement of a singular yellow solid line for a center line pavement marking is unacceptable. The edge line pavement markings shall be a white solid line.

On multilane primary and secondary roadways, apply and place temporary or permanent pavement markings, as specified hereupon, to the travel lanes prior to reopening a closed travel lane to traffic. These pavement markings shall include 4-inch wide solid lines, utilized for edge lines and solid center lines, and 4-inch wide by 10 feet long broken lines with a 30-foot gap, utilized for lane lines and turn lanes, unless otherwise specified. The center line pavement markings shall be either double yellow solid lines or an appropriate combination of a yellow solid line and 4-inch wide by 10 feet long yellow broken lines for two-way left turn median areas. The right edge line pavement markings shall be a white solid line and the left edge line shall be a yellow solid line except in areas where the travel lanes separate to create a gore type situation and then the color schemes shall comply with SCDOT application practices for gore areas. The lane lines between travel lanes and turn lanes shall be 4-inch wide by 10 feet long white broken lines with a 30-foot gap.

However, on two-lane two-way and multilane primary and secondary roadways, application of a 4-inch wide solid line utilized for an edge line adjacent to an earth shoulder, white or yellow, may be delayed up to 72 hours after eradication of the original line when the length of eradicated line at a single location is no longer than 250 feet. In the event of multiple locations along the same line, each location must be separated from the adjacent location by no less than 250 feet with a cumulative total distance of eradicated line of no more than 1300 feet within any continuous 1 (one) mile length of roadway measured from a selected location. If the length of eradicated line exceeds 250 feet at any single location, the distance interval between multiple adjacent locations is less than 250 feet or a cumulative total distance of multiple locations of eradicated line exceeds 1300 feet within any continuous 1 (one) mile length of roadway measured from a selected location, replace the eradicated line(s) prior to reopening the adjacent travel lane to traffic.

On interstate roadways, apply and place temporary or permanent pavement markings, as specified hereupon, to the travel lanes prior to reopening a closed travel lane to traffic. These pavement markings shall include 6-inch wide solid lines, utilized for edge lines, and 6-inch wide by 10 feet long white broken lines with a 30-foot gap, utilized for lane lines between travel lanes and auxiliary lanes, unless otherwise specified. The right edge line pavement markings shall be a white solid line and the left edge line shall be a yellow solid line except in areas where the travel lanes separate to create a gore type situation and then the color schemes shall comply with SCDOT application practices for gore areas.

On all roadways, apply and place white stop bars and white triangle yield bars in all locations where previous stop bars and triangle yield bars have been eradicated by the work. Apply and place white stop bars and white

triangle yield bars at intersections controlled by stop and yield signs within 72 hours of the eradication of the original pavement marking. Apply and place white stop bars at signalized intersections controlled by traffic control signals and at railroad crossings prior to reopening a closed travel lane to traffic.

Within the limits of existing turn lanes on all roadways, apply and place white arrows in all locations where previous arrows have been eradicated by the work unless otherwise directed by the RCE. Apply and place white arrows within 72 hours of the eradication of the original pavement markings. However, in regard to newly constructed turn lanes, apply and place white arrows the within turn lanes as directed by the RCE.

Within the limits of existing lane-drop sites on all roadways, apply and place white arrows in all locations where previous arrows have been eradicated by the work prior to the end of each day's work or shift or reopening the closed travel lane to traffic. In regard to newly constructed lane-drop sites, apply and place white arrows within the travel lane to be terminated prior to opening the travel lane to traffic and as directed by the RCE.

Sub-section 609.4.1.1.1 Application Requirements General (Revision to paragraph 8) -

On two-lane, two-way roadways, passing zones may be eliminated within the work zone through application of 4-inch double yellow centerline pavement markings if determined feasible and directed to do so by the Plans and/or the RCE. Apply no passing zone markings as specified by the Plans, the Specifications, the *MUTCD* and the RCE.

**2.6.11 Flagging Operations (Sub-section 610.4.1) –**

Sub-section 610.4.1.1 Flagging Operations (paragraph 1) -

Use a flagging operation to control the flow of traffic when two opposing directions of traffic must share a common travel lane. A flagging operation may be necessary during a lane closure on a two-lane two-way roadway, an intermittent ramp closure or an intermittent encroachment of equipment onto a portion of the roadway. Utilize flagging operations to direct traffic around work activities and maintain continuous traffic flow at reduced speeds when determined to be appropriate by the RCE. As stated above, flagging operations shall direct traffic around the work activities and maintain continuous traffic flow; therefore, stopped traffic shall not be required to stop for time durations greater than those listed below unless otherwise directed by the RCE. Begin measurement of the time interval

immediately upon the moment the Flagger rotates the Stop/Slow paddle to display the “Stop” condition to the approaching motorists.

LENGTH OF CLOSURE	MAXIMUM TIME DURATION FOR STOPPED TRAFFIC
1 MILE or LESS	5 Minutes
1 to 2 MILES	7 ½ Minutes

If the work activities require traffic to be stopped for periods greater than 5 to 7 ½ minutes as stated above, consider alternate work methods, conducting work activities during times of lowest traffic volumes such as during the hours of darkness or complete road closure with detour installation.

**2.6.12 Paving and Resurfacing (Sub-section 611.4.1) –**

Sub-section 611.4.1.2 Requirements (paragraph 8) -

Whenever travel lanes with acceptable grade elevation differences are open to traffic, provide “Uneven Lanes” signs (W8-11-48) or “Uneven Pavement” signs (W8-11A-48). Reflectorize these signs with a fluorescent orange colored prismatic retroreflective sheeting unless otherwise specified. Install these signs adjacent to roadways with uneven pavement surfaces between travel lanes or between travel lanes and the adjacent paved shoulders. Install these signs at intervals no greater than 2600 feet.

**2.7 STAGING**

**2.7.1 Traffic Control Restrictions (Project Specific)**

Maintain the existing number of I-26 mainline lanes of traffic in each direction during the times of the lane closure restrictions. Maintain the existing number of travel lanes for all on-ramps and off-ramps during the times of the lane closure restrictions unless otherwise approved by the Department. All ramps must maintain free-flow operation (no yield control) unless otherwise approved by the Department.

The presence of acceptable grade elevation differences less or equal to 1inch in milled areas or less than or equal to 2inches in paved areas adjacent to a travel lane open to traffic are prohibited during weekends

from 8:00 am Friday to 9:00 pm Sunday unless otherwise directed by the Engineer. When necessary, the weekend restriction may be extended due to the proximity of a holiday as directed by the Engineer.

The Contractor shall have no more than 72 hours to begin elimination of any grade elevation differences between or adjacent to the travel lanes of I-26. The 72 hour time period shall begin upon creation of the grade elevation difference. This restriction shall apply to all acceptable grade elevation differences less than or equal to 1inch in milled areas or less than or equal to 2inches in paved areas.

During surface planing and milling operations, the length of roadway with a milled surface open to traffic is restricted to 4 miles. This restriction does not apply to concrete diamond grinding operations.

During surface planing and milling operations, the length of roadway with an acceptable grade elevation difference less than or equal to 1inch adjacent to a single travel lane or between multiple travel lanes open to traffic is restricted to a maximum distance of 4 miles.

During asphalt paving operations, the length of roadway with an acceptable grade elevation difference less than or equal to 2inches adjacent to a single travel lane or between multiple travel lanes open to traffic is restricted to a maximum distance of 4 miles.

The Contractor may conduct various work activities in the same direction at various locations concurrently if approved by the Department. Various work activities in the same direction requiring simultaneous closures in the same travel lane or shoulder shall be separated by no less than 2 miles from the end of the first closure that a motorist will encounter to the beginning of the taper of the second closure. Also, various work activities in the same direction requiring simultaneous right and left lane closures or shoulder closures shall be separated by no less than 4 miles from the end of the first closure that a motorist will encounter to the beginning of the taper of the second closure.

### **3.0 DELIVERABLES**

#### **3.1 Conceptual Work Zone Traffic Control Plans**

The Contractor shall submit Conceptual Work Zone Traffic Control Plans in advance of the Final Plans submittal. The plans shall include, but not be limited to, the following:

- Staging Narrative
- Concept Staging Plans

- Widening/Rehabilitation Typical Sections for each Stage of Construction and any critical points
- Show areas where additional Right-of-Way is warranted for the purposes of Staging
- Show the Separation of Adjacent Travel Lanes / Traffic Splits as described in the SCDOT Procedures and Guidelines for Work Zone Traffic Control Design
- Show areas where the travel lane leaves the existing roadway bed or direction on new alignment (transition area) and returns (termination area)

### **3.2 Work Zone Traffic Control Plans**

The Contractor shall submit Work Zone Traffic Control Plans in the Final Plans Submittal. The plans shall be in accordance with the SCDOT Procedures and Guidelines for Work Zone Traffic Control Design and all other applicable design references listed in Exhibit 4.

# **EXHIBIT 4e**

## **HYDRAULIC DESIGN CRITERIA**



## 1.0 GENERAL

Perform all hydrologic and hydraulic drainage designs in accordance with the “SCDOT’s Requirements for Hydraulic Design Studies”, May 2009, Stormwater Quality Design Manual, and Project Design Criteria as listed in EXHIBIT 4. Designs, as a minimum, to address:

- Ditch Capacity and Stability
- Storm Sewer Systems
- Underdrains
- Cross-line Pipes and Non-Bridge Sized Culverts
- Bridge-Sized Culverts and Bridges
- Scour
- Sediment and Erosion Control
- Best Management Practices
- Stormwater Quality Design

## 2.0 CRITERIA

The Hydrology and Hydraulics Basis of Design Report prepared by Thomas & Hutton, dated May 2016, contains hydrologic and hydraulic information and preliminary designs for this project. This report is included under ATTACHMENT C for information only. Additionally, this report provides direction and supporting data regarding the repair, replacement, and/or modifications of existing pipes, culverts, inlets. Video inspections of the pipes have not been performed.

The existing four-lane divided highway will be expanded in the future. The preliminary designs account for a future I-26 widening that includes adding two lanes on both the Eastbound and Westbound sides of the interstate towards the median, for an ultimate buildout of eight lanes. Final drainage designs shall account for the future expansions.

### 2.1 Roadway Drainage

- 2.1.1 Evaluate the hydrologic and hydraulic conditions for roadway drainage. Ensure offsite areas that affect the hydraulic systems and outfalls of this project are accounted for.
- 2.1.2 Perform hydraulic analyses, including headwater and tail-water effects, on all cross-line and median drainage structures for the design storm event. Additionally, include the 50-year surcharging event for median inlets.
- 2.1.3 Design new and analyze existing closed-drainage systems with GEOPAK drainage software. Consider interstate ramps as primary roads. In areas where future widening is accounted for in the designs, ensure the proposed systems are not to be constructed under the future lanes.

- 2.1.4 Perform open channel designs. Include ditch capacity and stability analyses on the median, sideline and outfall ditches impacted within the limits of the project. Provide additional information and analyses for those locations where structures are upsized to verify post conditions will not create nor contribute to adverse downstream impacts. Minimize velocities to non-erosive rates.
- 2.1.5 Design temporary drainage systems for the 5-yr storm event and restrict spread to the shoulder width. Minimize ponding at flood sensitive locations and the low side of barrier walls.
- 2.1.6 Abandon pipes by filling with flowable fill. Note abandoned pipe locations on drainage sheets.
- 2.1.7 Replace all damaged Type-9 catch basins with Drop Inlet Type-112 (719-112-XX) within controlled access locations only. Replace all damaged Type-9 catch basins with Type-9 Ditch Installation (719-009-03) where practical. Replace all other damaged Type-9 catch basins using Type-9 Top Slabs with Integral Throat walls only (719-009-01). Repair or replace damaged inlets such as DI 24x24, Type-12 and Type-112.
- 2.1.8 The double 9’x’6 concrete box culverts for Ramp 4 (Sta. 402+30) and Ramp 1 (Sta. 162+34) have been designed and constructed as part of the Volvo Car Drive project. Additionally, as part of the Volvo Car Drive project, an outfall channel will be constructed from the southern Volvo Plant entrance (approximately 500 feet east of the Interchange tie to Volvo Car Drive), along the southern side of Volvo Car Drive to the upstream side of the double 9’x6’ CBC. The system design considers the contributing stormwater runoff to the system and the functionality of the stormwater management system from within the Volvo Plant site. The Contractor shall maintain the function of this system and verify the hydraulic capacity of these structures, ensuring they can accommodate the runoff associated with the new interchange. If Hydraulic Design Requirements and Criteria are not met, the Contractor shall perform appropriate upgrades to meet the Requirements and Criteria.
- 2.1.9 Perform field and video inspections on cross-line structures ~~that have not been inspected~~, in accordance with the SCDOT’s Pipe and Culvert Inventory and Inspection Guidelines (2011) with exceptions noted herein.
- 2.1.9.1 Inspect box culverts via direct measure techniques utilizing a video camera to document condition, jointing, and obstructions.

**EXHIBIT 4e – HYDRAULIC DESIGN CRITERIA**

2.1.9.2 Inspect pipes 18-inches and greater in diameter using a pipe camera system (no laser).

2.1.9.3 Perform a condition assessment to evaluate inlets, outlets, joints, cracks, spalling, slope, sediment, debris, efflorescence, and rust staining. Additionally note all drop inlet structural deficiencies and outfalls in need of regrading for positive drainage or armoring.

2.1.9.4 Prepare a report and summary table for **recommended proposed** alternatives. Acceptable alternatives are retain, replace, seal, clean, clean and line, or a combination of these. Label one table column *Evaluation of Pipe* **as depicted in 2.1.10** and list the **proposed chosen** alternatives. A SC Registered Professional Engineer shall sign the report.

2.1.10 **Implement the alternatives as directed in the below column *Evaluation of Pipe*.** Structures within the project limits may be replaced in lieu of repair. Verify the hydraulic capacity of the pipes and culverts. When analyses do not demonstrate compliance with the Hydraulic Requirements and Criteria, replace the structures or make other improvements to the system to achieve compliance. Analyses shall reflect the “n” value for the liner material and any reduction in diameter.

<b>Location</b>	<b>Side</b>	<b>I-26 Station</b>	<b>Measured Footage (ft)</b>	<b>Size</b>	<b>Evaluation of Pipe</b>
I-26 EB	XS	669+30	93	18"	Retain existing pipe, extend and modify end for grading
I-26 EB	XS	674+00	106	18"	Remove or abandon, place 127' 24" pipe, clean upstream grate inlet
I-26 EB	XS	679+72	88	18"	Retain existing pipe, extend and modify end for grading
I-26 EB	XS	693+35	61	18"	Remove or abandon
I-26 EB	XS	707+63	91	18"	Retain existing pipe, extend and modify end for grading
I-26 EB	XS	713+61	89	18"	Remove or abandon, place 119' 24" pipe

EXHIBIT 4e – HYDRAULIC DESIGN CRITERIA

I-26 EB	XS	718+97	89	24"	Retain existing pipe, extend and modify end for grading
I-26 EB	XS	727+95	88	18"	Remove or abandon, place 113'-24" pipe
I-26 EB	XS	751+97	100	18"	Remove or abandon, place 117'-24" pipe, clean downstream grate inlet
I-26 WB	XS	890+10	96	18"	Retain existing pipe, extend and modify end for grading
I-26 WB	XS	899+11	88	18"	Retain existing pipe, extend and modify end for grading
I-26 WB	XS	901+62	85	18"	Remove or abandon, place 116'-24" pipe
I-26 WB	XS	919+03	89	24"	Plug 18' of existing pipe prior to outlet
I-26 WB	XS	922+85	110	24"	Remove or abandon, place 112'-24" pipe, clean upstream grate inlet
I-26 WB	XS	936+70	106	18"	Remove or abandon, place 132'-24" pipe, clean upstream grate inlet
I-26 WB	XS	952+07	107	18"	Remove or abandon, place 127'-24" pipe, clean upstream grate inlet

## 2.2 Bridge Drainage

There are no existing bridge nor bridge-sized culverts within the project limits. Apply the below bridge design criteria to any new bridges or bridge-sized culverts that may be constructed.

2.2.1 Model natural, existing, and proposed conditions for bridges and bridge-sized culverts that are to be constructed, replaced, widened, or extended over stream crossings using the 1-D model HECRAS. Refer to the HECRAS Reference Manual v4.1 or latest edition for guidance on setting up cross sections and other inputs within the model. In addition to the four cross sections described within the Manual, include additional cross sections, a minimum 500 feet upstream and downstream, as necessary to achieve a downstream limit where a change in starting elevation will not affect the computed high-water depth at the bridge and the upstream limit extends to the limit of backwater from the bridge.

- 2.2.2 Submit the preliminary model setup and results to the SCDOT before finalizing the model. Summarize the inputs and outputs, to include backwater and freeboard.

### **2.3 Floodplains and Floodways**

- 2.3.1 This project falls within FEMA Flood Insurance Rate Maps (FIRMs) 45015C0535D and 45015C0350D for Berkeley County SC. Based on these FIRMs, there are no stream crossings within Special Flood Hazard Areas (SFHAs).

- 2.3.2 The Contractor shall continuously verify the FIRMs associated with this project are the most current ones available and is responsible to accommodate for any updates or modifications to these FIRMs that affect design.

### **2.4 Sediment and Erosion Control and Water Quality**

- 2.4.1 Determine the classification of the receiving waterbodies and note downstream impairments.

- 2.4.2 Develop a plan to meet the requirements of SCDOT's Construction Permit SCR160000 for erosion and sedimentation control during construction for the entire project length. In areas where sediment dams, basins, or ponds are required, include plots of these structures on the roadway cross sections.

- 2.4.3 Provide additional water quality treatment when outfalls discharge to 303(d) listed, TMDL, and other sensitive waters. Utilize vegetative practices where possible and structural controls when vegetative practices are not applicable at these outfalls. Exhaust all options prior to implementing structural controls.

- 2.4.4 Provide a six inch asphaltic concrete curb and flume on the low sides of the roadway where fill slopes are steeper than 3:1. Use curb detail (5) and placement detail (2) from Standard Drawing 803-105-00. Use flume details from Standard Drawing 403-205-01. Hand shape radius for curb at flumes. Space flumes a maximum of 100 feet but as needed to accommodate drainage for the facility. Provide riprap and geotextile for erosion control under riprap at the toe of the flume. At bridge ends, utilize standard drawing 403-205-01.

### **2.5 NPDES Permitting**

- 2.5.1 Prepare the NPDES permit package.

- Notice of Intent (NOI)

- Stormwater Pollution Prevention Plan (SWPPP)
- SCDOT/SCDHEC checklist
- A half-sized set of signed and sealed final drainage plans

2.5.2 The SCDOT reviews, signs and submits the package to SCDHEC.

2.5.3 Perform all coordination to obtain the permit.

### **3.0 DELIVERABLES**

Perform a thorough QC review of the submittals prior to submitting them to the SCDOT. The Engineer of Record, a licensed and registered Professional Engineer in the State of South Carolina, shall sign and seal all final submittals.

#### **3.1 Preliminary Hydraulic Design Submittal**

- One half-size set of Preliminary Roadway Drainage Plans
- One hard copy and electronic copy of the Preliminary Hydraulic Design Report, to include:
  - Roadway Drainage Design and Supporting Documentation- Pre/Post outfall summary, inlet spacing calculations, HW/D, GEOPAK summaries, open channel designs, and outlet protection calculations
  - Sediment and Erosion Control Plan and Supporting Design Calculations
  - Preliminary Hydraulic Model Design and Supporting Documentation (for each applicable location)
  - Video inspections for retained structures that were not previously inspected. Field and Video Inspection Summary Report and Table
- Address Permitting Requirements associated with Federal, State and Local Agencies

#### **3.2 Final Hydraulic Design Submittal**

- Three hard copies of the NPDES Permit Package (and one additional copy of the NOI)
- One hard copy and electronic copy of the Final Hydraulic Design Report
  - Final Roadway Drainage and Bridge Hydraulic Design Calculations
  - Scour Study and Supporting Documentation, at each applicable location
- One half-size set of Final Drainage Plans- include the hydrology data for bridges and culverts and pipes greater than 48-inches, label outlet and inlet (during- and post- construction) protection locations

# **EXHIBIT 4f**

## **GEOTECHNICAL DESIGN CRITERIA**

## 1.0 GENERAL

The following items, at a minimum, shall be included in the geotechnical design for this project:

- Design foundations for the proposed bridge structures. All subsurface exploration, geotechnical design, and construction for the Project shall be carried out in accordance with the design criteria below.
- Provide pile dynamic load testing as outlined in the design criteria and in accordance with the project specifications. The results shall be used to determine capacities of the associated foundation system.
- Design and provide ground improvements as necessary to meet required design criteria and performance limits.

## 2.0 CRITERIA

The Geotechnical Base Line Report (GBLR) prepared by S&ME dated January 21, 2016, has been provided in Attachment C for geotechnical information. In addition, soil test boring log input files have been provided electronically in gINT format and CPT raw data files have also been provided.

All geotechnical testing shall comply with the requirements of the SCDOT Geotechnical Design Manual (GDM), 2010, Version 1.1. Geotechnical design shall comply with the requirements stated below and the Special Provisions listed in Exhibit 5. Geotechnical information provided in the Appendix of the GBLR (field and lab data only) as part of this RFP is intended for use in the design of this project. The Contractor shall verify that geotechnical information provided in Attachment C meets the requirements for a geotechnical investigation for this specific project as required by the GDM. If the requirements of the GDM are not met, then the Contractor shall provide additional geotechnical investigation to meet the geotechnical requirements for this specific project.

### 2.1 Bridge

Design all bridge structures proposed for this project in accordance with the GDM.

The Contractor shall be responsible for the load testing of all foundations used on this project. All testing reports whether for driven piles or drilled shafts shall bear the legible seal, signature, and date of the testing firm's engineer registered as a Professional Engineer in the State of South Carolina. The Contractor's designer shall review and approve, in writing, all load test reports prior to submitting the reports to SCDOT for review and acceptance or comment. Comments made by SCDOT shall be reviewed and rectified by the Contractor's designer prior to the results of the load testing being used in design.



2.1.1 Pile Dynamic Load Testing with Pile Driving Analyzer

Pile dynamic load testing with Pile Driving Analyzer (PDA) testing shall be required for driven piles on the Project. The Contractor shall select a testing firm for PDA Testing from those firms currently approved to provide foundation testing services on SCDOT's Foundation Testing On-Call Contract. In addition to the PDA testing, CAPWAP (Case Pile Wave Analysis Program) analysis shall also be performed. The Contractor shall provide a Pile Installation Plan (PIP) that shall include the pile index testing program. The pile index testing program shall at a minimum include the Bent and Pile number of each pile to be tested as well as the number of index piles to be tested. The number of index piles shall conform to the requirements of the GDM.

**2.2 Roadway**

Design all new roadway structures required for the Project in accordance with the GDM. Geotechnical evaluation of new embankments shall be required in accordance with the GDM and applicable Bridge Design Memos.

Miscellaneous overhead structure foundations such as lighting and signage shall be designed in accordance with AASHTO Standard Specifications for Structural Supports for Highway Signs, Luminaires, and Traffic Signals, effective as of the Final RFP release date.

**2.3 Seismic**

Seismic design of the bridge structures, roadway structures, and new embankments shall be required in accordance with the SCDOT Geotechnical Design Manual and SCDOT Seismic Design Specifications for Highway Bridges. Seismic evaluation is required for all bridge embankments, regardless of fill height.

The Simplified Newmark method described in Section 13.17.2 and Equation 13-106 of the GDM shall be used to analyze seismic ground displacements along a shear plane. Calculated Newmark displacements shall be multiplied by 2 for all ROC I and ROC II embankments and roadway structures.

A one-dimensional non-linear site-specific response analysis (SSRA) has been performed for this project by S&ME. The SSRA report dated January 13, 2016 is attached in Appendix C for information only. Based on the SSRA report, single ADRS curves for the SEE and FEE design events have been developed for all structures bearing on deep foundations extending to or into the Marl and are supplied in this design criteria. Separate ADRS curves for the SEE and FEE design events are provided at the ground surface for embankment and roadway

**EXHIBIT 4f – GEOTECHNICAL DESIGN CRITERIA**

structure design. The ADRS curves are provided below and shall be used for all seismic design on the Project.

The provided curves are the final design curves for the Project. Submittal of ATC's for site-specific site response analyses will not be approved.

**Volvo Interchange – Ground Surface**

Design EQ	PGA	S <sub>DS</sub>	S <sub>D1</sub>
FEE	0.24	0.53	0.16
SEE	0.54	0.93	0.86

**Volvo Interchange – Top of Marl**

Design EQ	PGA	S <sub>DS</sub>	S <sub>D1</sub>
FEE	0.16	0.27	0.15
SEE	0.42	1.33	0.78

EXHIBIT 4f – GEOTECHNICAL DESIGN CRITERIA

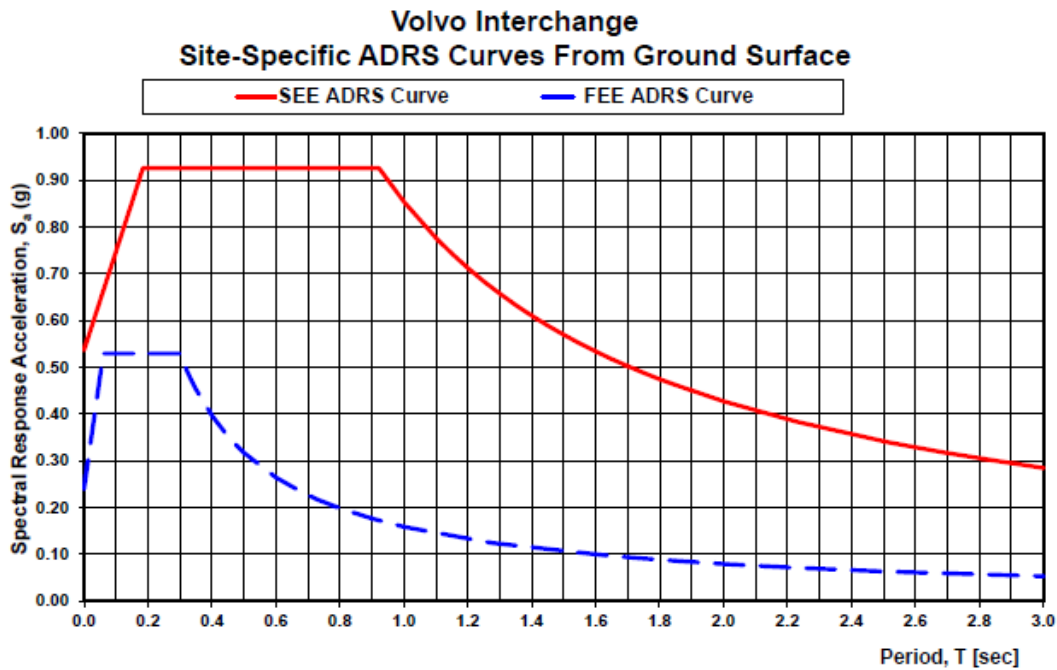

FEE ADRS Curve Site-Specific		SEE ADRS Curve Site-Specific	
T	$S_a$	T	$S_a$
0.00	0.240	0.00	0.537
0.01	0.288	0.01	0.558
0.02	0.336	0.10	0.748
0.03	0.385	0.15	0.853
<b>To</b> 0.06	0.529	<b>To</b> 0.18	0.926
0.10	0.529	0.25	0.926
0.15	0.529	0.50	0.926
0.17	0.529	0.75	0.926
<b>Ts</b> 0.30	0.529	<b>Ts</b> 0.92	0.926
0.31	0.511	1.00	0.854
0.32	0.495	1.10	0.777
0.33	0.480	1.15	0.743
0.35	0.452	1.20	0.712
0.40	0.396	1.25	0.683
0.45	0.352	1.30	0.657
0.50	0.317	1.35	0.633
0.60	0.264	1.40	0.610
0.68	0.233	1.45	0.589
0.73	0.217	1.50	0.569
0.80	0.198	1.55	0.551
0.90	0.176	1.60	0.534
1.00	0.158	1.65	0.518
1.27	0.124	1.70	0.502
1.64	0.097	1.75	0.488
1.74	0.091	1.80	0.475
1.85	0.086	1.85	0.462
2.00	0.079	2.00	0.427
2.23	0.071	2.23	0.383
2.52	0.063	2.52	0.339
2.69	0.059	2.69	0.318
2.86	0.055	2.86	0.299
3.00	0.053	3.00	0.285

EXHIBIT 4f – GEOTECHNICAL DESIGN CRITERIA

Volvo Interchange - Deep Foundations Bearing on Marl  
Site-Specific ADRS Curves from Top of Marl

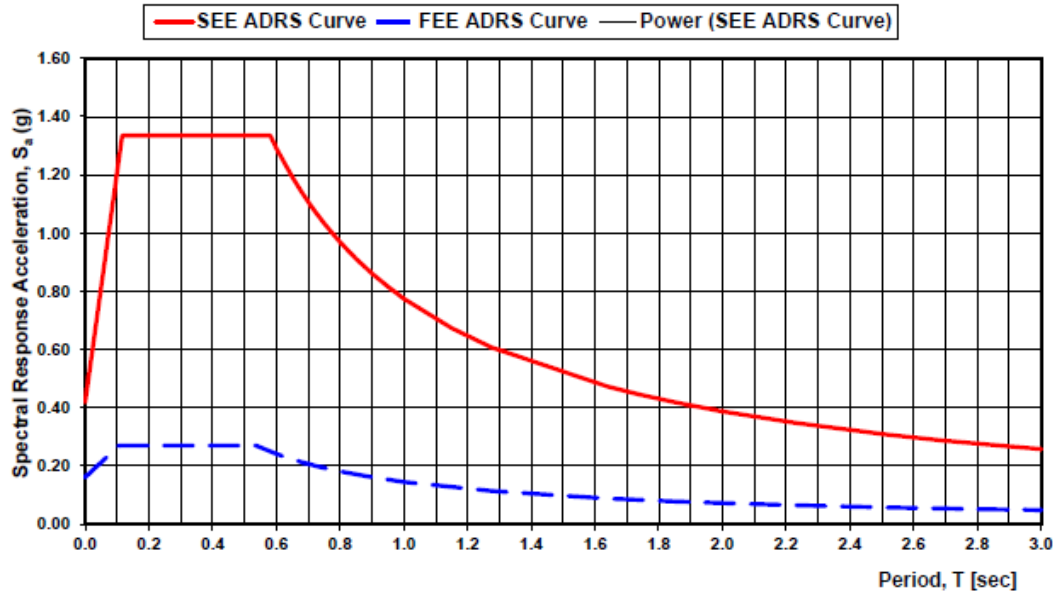

FEE ADRS Curve Site-Specific		SEE ADRS Curve Site-Specific	
T	$S_a$	T	$S_a$
0.00	0.162	0.00	0.420
0.01	0.172	0.01	0.498
0.02	0.182	0.02	0.577
0.03	0.192	0.03	0.656
To	0.11	To	0.12
	0.270		1.334
0.13	0.270	0.13	1.334
0.15	0.270	0.15	1.334
0.25	0.270	0.17	1.334
Ts	0.54	Ts	0.58
	0.270		1.334
0.60	0.242	0.60	1.291
0.62	0.234	0.65	1.192
0.64	0.226	0.68	1.139
0.66	0.220	0.70	1.107
0.68	0.213	0.72	1.076
0.70	0.207	0.75	1.033
0.72	0.201	0.78	0.993
0.74	0.196	0.80	0.968
0.76	0.191	0.85	0.911
0.78	0.186	0.90	0.861
0.80	0.181	0.95	0.815
0.90	0.161	1.00	0.775
1.00	0.145	1.15	0.674
1.27	0.114	1.27	0.608
1.64	0.088	1.64	0.472
1.74	0.083	1.74	0.445
1.85	0.078	1.85	0.419
2.00	0.072	2.00	0.387
2.23	0.065	2.23	0.347
2.52	0.058	2.52	0.307
2.69	0.054	2.69	0.288
2.86	0.051	2.86	0.271
3.00	0.048	3.00	0.258

### 3.0 DELIVERABLES

Geotechnical reports shall, at a minimum, contain all that is described in Chapter 21 of the SCDOT Geotechnical Design Manual and the latest design memorandums. The reports shall contain design details and plan notes along with data that are consistent with that shown in the preliminary and final bridge and road plans. In addition, the Contractor's designer shall prepare the required geotechnical bridge and roadway plan sheets that clearly detail any geotechnical requirements outlined in the reports. The reports and plans shall bear the legible seal, date, and signature of the responsible engineer registered as a Professional Engineer in the State of South Carolina. Submit each report to SCDOT along with the preliminary or final bridge or roadway plan submittal. The review of the reports and plans will be performed in accordance with the submittal plan review process.

All submittals to SCDOT shall be thoroughly QC reviewed by the Contractor prior to submittal and all final submittals shall be signed and sealed by the Engineer of Record who shall be licensed and registered as a Professional Engineer in the State of South Carolina.

#### 3.1 Preliminary Geotechnical Design Submittals

The Contractor shall submit to SCDOT:

- Electronic Copy of the Preliminary Subsurface Investigation Plan prior to performing the preliminary subsurface investigation.
- Electronic Copy of the Preliminary Bridge Geotechnical Engineering Report for each bridge structure.
- Electronic Copy of the Preliminary Roadway Geotechnical Engineering Report to include roadway embankments, retaining walls, culverts, and any other roadway structures.
- Preliminary Structural Plans with the Preliminary Bridge Geotechnical Engineering Report and Preliminary Roadway Plans with the Preliminary Geotechnical Roadway Engineering Report.

#### 3.2 Final Geotechnical Design Submittals

The Contractor shall submit to SCDOT:

- Electronic Copy of the Final Subsurface Investigation Plan prior to performing the final subsurface investigation.
- Electronic Copy of the Final Bridge Geotechnical Engineering Report for each bridge structure.
- Electronic Copy of the Final Roadway Geotechnical Engineering Report to include roadway embankments, retaining walls, culverts, and any other roadway structures.
- Final Structural Plans with the Final Bridge Geotechnical Engineering Report and Final Roadway Plans with the Final Geotechnical Roadway Engineering Report.

**3.3 Foundation Installation Plan Submittals**

Prepare Drilled Foundation Installation Plans (DFIP) and/or Pile Installation Plans (PIP) in accordance with the SCDOT Standard Specifications for Highway Construction, 2007 Edition. Submit all foundation installation plan submittals electronically. The Contractor's designer shall review and approve all DFIP and PIP (including pile driving criteria) prior to submitting the foundation installation plans to SCDOT for review and acceptance. SCDOT will review the foundation installation plans and provide either acceptance or comments. The Contractor's designer shall resolve all comments prior to re-submittal to SCDOT. SCDOT will review the DFIP and/or the PIP only to verify that the specifications have been addressed. The Contractor shall provide a supplement to the report containing the actual field conditions encountered and as-built foundation data and information after construction of the foundations is complete.

**3.4 Foundation Testing Submittals**

Submit to SCDOT an electronic copy of all applicable foundation testing reports for all bridge and roadway structures to include but not limited to Pile Driving Analyzer test reports.

# **EXHIBIT 4g**

## **ENVIRONMENTAL DESIGN CRITERIA**

**1.0 GENERAL COMMITMENTS**

The Agreement, Article X, includes details related to Environmental Compliance. The NEPA documents and other environmental information are provided in Attachment B. The Contractor shall avoid impacts to the environment to the maximum extent practicable. In cases where impacts cannot be avoided, the Contractor shall minimize impacts to the environment to the most practicable extent. As a minimum the Contractor shall include the following in the Project:

- 1) The Contractor is responsible for the preparation, revision, acquisition, and adherence to conditions of any permits required by federal, state, local laws or regulations.
- 2) The Contractor is responsible for any modifications or revisions to the environmental documents and permits that result from deviations in the project design and environmental impacts as stated in the environmental documents (including but not limited to mitigation plan revisions).
- 3) The Contractor shall provide an Environmental Compliance Plan for the Project. The plan shall be submitted to SCDOT for review and approval prior to any construction activity. The plan shall identify all specific measures that the Contractor will implement to assure compliance with all federal, state and local laws & regulations including, but not limited to, environmental documents, permits, and environmental commitments. The plan shall also designate specific personnel that are charged with carrying out monitoring and compliance activities included in the Environmental Compliance Plan.
- 4) Fines assessed by any agencies to the Permittee as the result of the Contractor’s non-compliance or violation of said permit provisions shall be paid by the Permittee and subsequently deducted from the Contractor’s monthly pay estimate.
- 5) The Contractor shall coordinate all permitting through SCDOT’s Environmental Services Office.
- 6) Contractor responsible for providing to SCDOT a summary report documenting how all commitments that fall within his responsibility have been satisfied. Prior to Final Completion, the Contractor shall prepare and submit to SCDOT an Environmental Commitment Summary Report that summarizes the Contractor’s compliance with the above listed commitments and includes all supporting documentation for that specific commitment. The Contractor shall provide two hard copies and one PDF copy of the document.

**2.0 ENVIRONMENTAL DOCUMENT COMMITMENTS**

The Contractor shall comply with all Environmental Commitments related to the Project. The following list of Environmental Commitments and instructions serves as a guideline for the relationship between SCDOT and the Contractor as it pertains to fulfilling the Environmental Commitments for the Project.



EXHIBIT 4g – ENVIRONMENTAL DESIGN CRITERIA

Commitment	Responsible Party	Source
<p><b>USACE MFR Environmental Assessment*Department of the Army Permit SAC-2015-0476-SIR</b></p>		
<p>That the permittee agrees to provide all contractors associated with construction of the authorized activity a copy of the permit and drawings. A copy of the permit will be available at the construction site at all times.</p>	<p><i>BERKELEY COUNTY/SCDOT/CONTRACTOR</i></p>	<p>USACE MFR/EA</p>
<p>That the permittee shall submit a signed compliance certification to the Corps within 60 days following completion of the authorized work and any required mitigation. The certification will include:</p> <ol style="list-style-type: none"> <li>1. A copy of this permit;</li> <li>2. A statement that the authorized work was done in accordance with the Corps authorization, including any general or specific conditions;</li> <li>3. A statement that any required mitigation was completed in accordance with the permit conditions;</li> <li>4. The signature of the permittee certifying the completion of the work and mitigation.</li> </ol>	<p><i>BERKELEY COUNTY/SCDOT/CONTRACTOR</i></p> <p><i>The contractor is responsible for the closeout of items under the contractor’s responsibility and the Summary Report described in Section 1.6. SCDOT will be responsible for coordination with Berkeley County and the Corps and final certification of the permit.</i></p>	<p>USACE MFR/EA</p>

<p>1. That as compensatory mitigation to offset impacts to aquatic resources, the permittee will implement and fully comply with the “Project Soter – Landscape Mitigation Plan” dated April 10, 2015 (revised July 8, 2015) (the Plan), including the provision to provide \$1.5 million into an escrow account to be held by Lord Berkeley Conservation Trust, and to also provide a Corps-approved performance bond as financial assurance for the mitigation activities proposed in the Plan. Your responsibility to complete the Plan as set forth in this Special Condition will not be considered fulfilled until you have demonstrated mitigation success and have received written verification from the U.S. Army Corps of Engineers (Corps).</p> <p>2. The permittee understands and agrees that a Corps-approved performance bond must be in place prior to commencement of the authorized work, and may not be terminated until the Corps verifies in writing that the compensatory mitigation requirement for the proposed project has been satisfied.</p> <p>3. That the permittee must submit evidence of execution and recording of the Corps-approved conservation easements and surveyed plat of the mitigation area to both the Corps and DHEC not later than 180 days from the effective date of this authorization, or prior to commencement of the authorized work, whichever is later.</p>	<p style="text-align: center;"><i>BERKELEY COUNTY</i></p>	<p style="text-align: center;">USACE MFR/EA</p>
--	---	---

EXHIBIT 4g – ENVIRONMENTAL DESIGN CRITERIA

<p>That the permittee agrees to utilize best management practices during construction and perform the work as proposed. The permittee must implement practices that will minimize erosion and migration of sediments on and off the project site during and after construction. These practices should include the use of appropriate grading and sloping techniques, mulches, silt fences, or other devices capable of preventing erosion, migration of sediments and bank failure. All disturbed land surfaces and sloped areas affected by the project must be stabilized.</p> <ol style="list-style-type: none"> <li>1. All necessary steps must be taken to prevent oil, tar, trash, debris, and other pollutants from entering the adjacent waters or wetlands.</li> <li>2. Land disturbing activities must avoid encroachment into any wetland areas outside the permitted impact area.</li> <li>3. Upon completion of construction activities, all disturbed areas, which are not paved, must be permanently stabilized with a vegetative cover. This may include sprigging trees, shrubs, vines or ground cover.</li> </ol>	<p style="text-align: center;"><i>CONTRACTOR</i></p>	<p style="text-align: center;">USACE MFR/EA</p>
<p>That the permittee agrees that the drainage/conveyance system shall be designed by a licensed Professional Engineer (PE) and constructed by the permittee (or his designated assignee) to provide for the proper drainage of surface water of the drainage area of which it is a part, to permit the flow of natural or manmade watercourses, and to maintain positive drainage for adjacent properties. In addition, the drainage/conveyance system shall be sufficient to prevent any appreciable increase in water surface elevations or expansion/increases of the flood hazard area.</p>	<p style="text-align: center;"><i>CONTRACTOR</i></p>	<p style="text-align: center;">USACE MFR/EA</p>

EXHIBIT 4g – ENVIRONMENTAL DESIGN CRITERIA

<p>That the permittee agrees to stop work and to notify this office immediately if any previously unknown historic or archaeological remains are discovered while accomplishing the activity authorized by this permit. The Corps will initiate the Federal, State, and/or Tribal coordination required to determine if the remains warrant a recovery effort or if the site is eligible for listing in the National Register of Historic Places.</p>	<p><i>SCDOT/CONTRACTOR</i></p> <p><i>SCDOT will be responsible for agency coordination and the evaluation/recovery of any unanticipated historic or archaeological remains. The contractor is responsible for stopping work and notifying the Resident Construction Engineer in the event of an unanticipated or late discovery. Compensation for work stoppage/delays will follow guidance described in Articles III and IV of the Agreement.</i></p>	<p>EA_FONSI</p>
<p><b>Final State 401 Certification</b></p>		
<p>Only clean earthen materials, free of all potential sources of pollution must be used as fill</p>	<p><i>CONTRACTOR</i></p>	<p>401 Certification</p>
<p>A revised mitigation plan to supplement the Landscape Mitigation Plan must be submitted to and approved by SCDHEC within 180 days of issuance of a Department of the Army permit by USACE</p>	<p><i>BERKELEY COUNTY/CONTRACTOR</i></p> <p><i>See Section 1.2.</i></p>	<p>401 Certification</p>
<p>All enhancement and restoration activities described in the Landscape Mitigation Plan must be completed within five years of the issuance of a Department of the Army permit</p>	<p><i>BERKELEY COUNTY</i></p>	<p>401 Certification</p>
<p>Copies of the signed recorded plats and conservation easements (or other restrictions acceptable to the SCDHEC and the USACE) for the Bannister, Mimms, Dean Swamp, Singletary, Long and Salisbury Tracts as identified in the Landscape Mitigation Plan must be submitted to SCDHEC within 180 days of issuance of a Department of the Army permit by the USACE</p>	<p><i>BERKELEY COUNTY</i></p>	<p>401 Certification</p>
<p>Annual monitoring reports must be submitted to SCDHEC and the USACE for a period of five years after issuance of a Department of the Army permit until performance standards are met.</p>	<p><i>BERKELEY COUNTY</i></p>	<p>401 Certification</p>

EXHIBIT 4g – ENVIRONMENTAL DESIGN CRITERIA

<p>Financial assurances, such as a performance bond, letter of credit or other mechanism as approved by SCDHEC must be provided for the mitigation activities. The amount of the financial assurance shall be an amount that is reasonably estimated to cover the cost of the proposed mitigation activities ( restoration, enhancement, and monitoring costs) and must be submitted to SCDHEC within 90 days of issuance of a Department of the Army permit by the USACE.</p>	<p align="center"><i>BERKELEY COUNTY</i></p>	<p align="center">401 Certification</p>
<p>Final storm water management plan(s) submitted to the Department for NPDES coverage must comply with the applicable Storm water Management Guidelines as set forth in the SCCZMP Program Refinements</p>	<p align="center"><i>CONTRACTOR</i></p>	<p align="center">401 Certification</p>
<p><b>SCDOT/FHWA NEPA ENVIRONMENTAL COMMITMENTS</b></p>		
<p>The selected contractor will send a set of final plans and request of floodplain management compliance to the local County Floodplain Administrator</p>	<p align="center"><i>CONTRACTOR</i></p>	<p align="center">Project Soter Commitments</p>
<p>If avoidance of hazardous materials is not a viable alternative and the soils that appear to be contaminated are encountered during construction, SCDHEC will be informed. Hazardous materials will be tested and removed and/or treated in accordance with the USEPA and SCDHEC requirements if necessary.</p>	<p align="center"><i>CONTRACTOR</i></p> <p align="center"><i>Contractor's responsibility in accordance with Agreement Article XI.</i></p>	<p align="center">Project Soter Commitments</p>
<p>The contractor will be required to minimize possible water quality impacts through implementation of construction BMPs, reflecting policies contained in 23 CFR 650B and the Department's Supplemental Specifications on Seeding and Erosion Control Measures ( Latest Edition ). Other measures including seeding, silt fences, sediment basins, etc.. as appropriate will be implemented during construction to minimize impacts to Water Quality.</p>	<p align="center"><i>CONTRACTOR</i></p>	<p align="center">Project Soter Commitments</p>

EXHIBIT 4g – ENVIRONMENTAL DESIGN CRITERIA

<p>Storm water control measures, both during construction and post-construction, are required for SCDOT projects with land disturbances and/or constructed in the vicinity of 303(d), TMDL, ORW, tidal, and other sensitive waters in accordance with the SCDOT's MS4 Permit. The selected contractor would be required to minimize potential storm water impacts through implementation of construction best management practices, reflecting policies contained in 23 CFR 650 B and SCDOT's Supplemental Specifications on Seed and Erosion Control Measures(latest edition).</p>	<p><i>CONTRACTOR</i></p>	<p>Project Soter Commitments</p>
<p>That as compensatory mitigation to offset impacts to aquatic resources, the permittee will implement and fully comply with the "Project Soter -- Landscape Mitigation Plan" dated April 10, 2015 (revised July 8, 2015) ( the Plan), including the provision to provide 1.5 million into an escrow account to be help by Lord Berkeley Conservation Trust, and to also provide a Corps-approved performance bond as financial assurance for the mitigation activities proposed in the Plan. Your responsibility to complete the Plan as set forth in this Special Condition will not be considered fulfilled until you have demonstrated mitigation success and have received written verification from the US Army Corps of Engineers</p>	<p><i>BERKELEY COUNTY</i></p>	<p>Project Soter Commitments</p>
<p>The permittee understands and agrees that a Corps-approved performance bond must be in place prior to commencement of the authorized work, and may not be terminated until the Corps verifies in writing the compensatory.</p>	<p><i>BERKELEY COUNTY</i></p>	<p>Project Soter Commitments</p>

**3.0 ENVIRONMENTAL COMMITMENTS SUMMARY REPORT**

Prior to Final Completion, the Contractor shall prepare and submit to SCDOT an Environmental Commitment Summary Report that summarizes the Contractor's compliance with the above listed commitments and includes all supporting documentation for that specific commitment. The Contractor shall provide two hard copies and one PDF copy of the document.

## **EXHIBIT 5**

# **SPECIAL PROVISIONS AND CONTRACT REQUIREMENTS**



## Table of Contents

<b>SPECIAL PROVISIONS .....</b>	<b>3</b>
(1) SECTION 101: STANDARD DRAWINGS: .....	3
(2) SECTION 102: IMMINENT STANDARD DRAWINGS .....	3
(3) SECTION 103: STANDARD DRAWING ERRATA:.....	3
(4) SECTION 103: BONDS AND INSURANCE: .....	4
(5) SECTION 103: MOBILIZATION – SUBCONTRACTOR:.....	5
(6) SECTION 105: AUTOMATED MACHINE GUIDANCE: .....	5
(7) SECTION 106: PLANT/FABRICATOR INSPECTION: .....	7
(8) SECTION 106: QUALIFIED PRODUCT LISTINGS: .....	8
(9) SECTION 106: SOUTH CAROLINA MINING ACT:.....	8
(10) SECTION 107: FAIR LABOR STANDARDS ACT OF 1938, AS AMENDED: .....	8
(11) SECTION 107: CONTRACT PROVISION TO REQUIRE CERTIFICATION AND COMPLIANCE CONCERNING ILLEGAL ALIENS:.....	8
(12) SECTION 107: IRAN DIVESTMENT ACT: .....	8
(13) SECTION 107: MONITORING OF CONSTR.-RELATED EARTHBORNE VIBRATIONS:.....	9
(14) SECTION 107: COMMUNITY AND PUBLIC RELATIONS PLAN:.....	11
(15) SECTION 108: PARTNERING: .....	13
(16) SECTION 109: REFERENCES TO UNIT PRICING:.....	13
(17) SECTION 109: FUEL ADJUSTMENT INDEXES: .....	13
(18) SECTION 202: RECLAIMING EXISTING ROADWAY: .....	14
(19) SECTION 202: REMOVAL OF EXISTING GUARDRAIL:.....	14
(20) SECTION 203: MUCK EXCAVATION: .....	15
(21) SECTION 203: BORROW EXCAVATION: .....	16
(22) SECTION 203: BORROW EXCAVATION (FOR SHOULDERS): .....	17
(23) SECTION 203: BORROW PITS:.....	17
(24) SECTION 204: TEMPORARY SHORING WALL: .....	18
(25) SECTION 205: LIGHTWEIGHT AGGREGATES:.....	19
(26) SECTION 205: HIGH-STRENGTH GEOTEXTILE FOR EMBANKMENT REINFORCEMENT: .....	20
(27) SECTION 205: MONITORING DEVICES – PIEZOMETER:.....	28
(28) SECTION 205: SETTLEMENT PLATES: .....	29
(29) SECTION 205: SETTLEMENT SENSORS:.....	34
(30) SECTION 205: VIBRATING WIRE ROD EXTENSOMETER: .....	38
(31) SECTION 205: VIBRATING WIRE DATA COLLECTION CENTERS: .....	41
(32) SECTION 205: VIBRO COMPACTION:.....	43
(33) SECTION 205: DEEP SOIL MIXING (DSM): .....	46
(34) SECTION 205: GROUND MODIFICATION – COMPACTION GROUTING COLUMNS: .....	69
(35) SECTION 205: GROUND MODIFICATION – VIBRO-STONE COLUMN (VIBRO-DISPL.): .....	75
(36) SECTION 305: MAINTENANCE STONE: .....	79
(37) SECTION 401: DRESSING OF SHOULDERS:.....	79
(38) SECTION 401: HOT MIXED ASPHALT (HMA) PAVEMENT: .....	79
(39) SECTION 401: HOT MIX ASPHALT (HMA) QUALITY ASSURANCE:.....	79
(40) SECTION 401: HOT-MIX ASPHALT RIDEABILITY: .....	79
(41) SECTION 401: ASPHALT BINDER ADJUSTMENT INDEX: .....	80
(42) SECTION 401: SURFACE PLANING OF ASPHALT PAVEMENT:.....	80
(43) SECTION 401: FULL DEPTH ASPHALT PAVEMENT PATCHING: .....	82
(44) SECTION 403: PAVING UNDER GUARDRAIL:.....	83
(45) DIVISION 400 & 500: CROSS SLOPE VERIFICATION:.....	87
(46) DIVISION 600: EVALUATION OF RETROREFLECTIVITY: .....	91
(47) DIVISION 600: MANUAL ON UNIFORM TRAFFIC CONTROL DEVICES:.....	91

**EXHIBIT 5 – SPECIAL PROVISIONS AND CONTRACT REQUIREMENTS**

(48) SECTION 601: PENALTY FOR VIOLATING LANE CLOSURE RESTRICTIONS:.....92  
(49) SECTION 605: PERMANENT CONSTRUCTION SIGNS: .....92  
(50) SECTION 610: WORK ZONE TRAFFIC CONTROL PROCEDURES:.....92  
(51) SECTION 653: RETROREFLECTIVE SIGN POST PANELS: .....92  
(52) DIVISION 700: ANTI-GRAFFITI COATING: .....93  
(53) SECTION 701: SAND LIGHTWEIGHT CONCRETE: .....95  
(54) SECTION 701: NON-CONFORMING CONCRETE: .....96  
(55) SECTION 711: PILE AND DRIVING EQUIPMENT DATA FORM: .....97  
(56) SECTION 711: GALVANIZED STEEL H PILING AND SWAY BRACES: .....97  
(57) SECTION 712: DRILLED SHAFT FORMS: .....98  
(58) SECTION 714: SMOOTH WALL PIPE:.....98  
(59) SECTION 714: PIPE END TREATMENTS (2/5/2010):.....100  
(60) SECTION 719: CAST IN PLACE CONCRETE PIPE COLLAR: .....103  
(61) SECTION 727: CROSSHOLE SONIC LOGGING OF DRILLED SHAFT FOUNDATIONS: .....103  
(62) DIVISION 800: GEOTEXTILE FOR DRAINAGE FILTRATION: .....103  
(63) DIVISION 800: GEOCOMPOSITE WALL DRAIN: .....105  
(64) SECTION 805: THREAD LOCKING GUARDRAIL HARDWARE: .....108  
(65) SECTION 805: TL3 TYPE T TANGENT END TERMINALS: .....108  
(66) SECTION 806: REPAIR EXISTING CONTROL OF ACCESS FENCE: .....108  
(67) SECTION 815: EROSION CONTROL MEASURES:.....109  
(68) SECTION 815: ANIONIC POLYACRYLAMIDE FOR EROSION CONTROL:.....111

**SPECIAL PROVISIONS**

**(1) SECTION 101: STANDARD DRAWINGS:**

The Bidders are hereby advised that this project shall be constructed using the 2013 Standard Drawings with all updates effective at the time of this letting. For this design-build project, the time of the letting is the most recent Standard Highway Letting that occurred on or before the Final RFP release date. The Standard Drawings are available for download at [http://www.scdot.org/doing/sd\\_Disclaimer.aspx](http://www.scdot.org/doing/sd_Disclaimer.aspx). All drawings that are updated are labeled with their effective letting date in red.

The Standard Drawings are available to purchase through the SCDOT Engineering Publications Sales Center. The Engineering Publication Sales Center is located in Room G-19 (basement level) of the SCDOT Headquarters Building, 955 Park Street, Columbia, South Carolina.

All references in the plans, standard specifications, supplemental specifications, supplemental technical specifications or special provisions to drawings under the previous numbering system are hereby updated to the new drawing numbers. Refer to sheets 000-205-01 through 000-205-07 to find new drawing numbers when looking for references to older drawing numbers.

**(2) SECTION 102: IMMINENT STANDARD DRAWINGS**

When referenced here, any Imminent drawing indicated is the required contract document for the respective items.

*[There are currently no imminent drawings that apply on this contract]*

**(3) SECTION 103: STANDARD DRAWING ERRATA:**

The Bidders are hereby advised that the following note changes apply to the published Standard Drawings.

On sheet 000-205-05, add the following information under the columns below:

OLD DRAWING NAME	NEW DRAWING NAME
720-905-01 to 720-905-05	720-901-01 to 720-993-32

On sheet 605-005-05, replace entire text of General Note #4 with the following text:

4. The square footage of sign panels attached to 2½” x 2½” 12 gauge sign support secured to a 3” x 3” 7 gauge breakaway anchor shall not exceed 20 square feet.

On sheet 720-305-00, delete the entire note directly above main detail:

~~If sidewalk exists, the driveway opening should...~~

On sheet 720-405-00 Detail 2 replace dimension 2’-6” maximum with:

2’-6” minimum

On sheet 720-901-01 replace note 5.04 with:

5.04 When a mid-block crossing is required, consider mid-block staggered crossing (720-955-41) to encourage eye contact between the pedestrian and the oncoming traffic. Always angle the stagger so that the pedestrian travels through the refuge facing the oncoming traffic.

On sheet 722-305-00 Detail 4 replace note “French Drain see note 21” with:

French Drain see note 4.5.

## EXHIBIT 5 – SPECIAL PROVISIONS AND CONTRACT REQUIREMENTS

On sheet 722-305-00 table 722-305A, 4<sup>th</sup> column, change the following:

Delete (SF)

Replace text “up to 36” with “up to 3’X3’ ”

Replace text “larger than 36” with “larger than 3’X3’ ”

On sheet 804-105-00 Title Block replace text “Rirap (Bridge End)” with:

Riprap (Bridge End)

On sheet 805-325-00 detail 2 replace text “rectangular washers (FWR03) See 805-005-00” with:

“rectangular washers (FWR03) See 805-090-00”

On sheet 805-325-00 change text of note 5 to the following:

5. For project specific requirements such as additional offset blocks, extra length posts, and post attachment details, see Project Plans. Include all costs of project specific requirements in the Guardrail Thrie-Beam Bridge Connector pay item.

On sheet 805-330-00 detail 2 replace text “rectangular washers (FWR03) See 805-005-00” with:

“rectangular washers (FWR03) See 805-090-00”

On sheet 805-330-00 change text of note 4 to the following:

4. For project specific requirements such as additional offset blocks, extra length posts, and post attachment details, see Project Plans. Include all costs of project specific requirements in the Guardrail Thrie-Beam Bridge Connector pay item.

On sheet 805-510-00 detail 3 replace guardrail base plate note with the following:

See standard drawings 805-655-xx for guardrail base plate options.

On sheet 805-655-M1 replace note 30.4 with the following:

30.4 Install adhesive anchors to a depth sufficient to develop a minimum factored (reduced) ultimate tensile capacity of 21 kips per anchor bolt. Increase minimum embedment shown in detail 4 as required by adhesive manufacturer’s recommendations for the existing material properties, anchor bolt pattern, edge conditions, and any other design reduction.

On sheet 815-002-00 Type B, D1, & D2 Inlet Structure Filters, revise as follows:

Replace all references to #5 stone with #5 or #57 stone.

On sheet 815-305-00 Sediment Control Structure and Basin, revise as follows:

Replace all references of #5 stone with #5 or #57 stone.

On sheet 815-405-00 Sediment Dams, revise as follows:

Replace all references of #5 stone with #5 or #57 stone.

Payment for either #5 or #57 stone will be made under the pay item for **Aggregate No. 5 for Erosion Control (6 “ Uniform)**

### (4) SECTION 103: BONDS AND INSURANCE:

Bonds and Insurance consists of all Bonds and Insurance required of the contractor. A maximum allowable amount of 2.0% of the total contract amount will be paid on the first pay estimate after work begins. If there is a remaining amount of the lump sum price for Bonds and Insurance after

**EXHIBIT 5 – SPECIAL PROVISIONS AND CONTRACT REQUIREMENTS**

payments are made according to the limit above, then the remaining amount will be paid on the final estimate.

- A. If special insurance is required by the contract provisions, such as railroad or coastal insurance, no maximum limit will apply to this bid item.

<b>Item No.</b>	<b>Pay Item</b>	<b>Unit</b>
1032010	BONDS AND INSURANCE	LS

**(5) SECTION 103: MOBILIZATION – SUBCONTRACTOR:**

Mobilization – Subcontractor consists of the preparatory operations for subcontractors including: moving personnel and equipment to the project site; paying bond and insurance premiums; establishing offices, buildings, and other facilities necessary for work on the project; and all other preparatory work or costs incurred before beginning work on the project.

Mobilization - Subcontractor is paid at the lump sum price bid, which price and payment is full compensation for organizing and moving all subcontractor forces, supplies, equipment and incidentals to the project site, regardless of the number of times such moves are made. The price and payment also includes costs for demobilization.

When the item Mobilization – Subcontractor is included in the bid items, payment will be made on the first four construction estimates. Each payment is for 25% of the lump sum price for Mobilization - Subcontractor, subject to the maximum total limit of 5.0% of the total contract amount.

If there is a remaining amount of the lump sum price for Mobilization after payments are made according to the limit above, then the remaining amount is paid after all work on the project has been completed and accepted.

Partial payment for this item in no way acts to preclude or limit any of the provisions of partial payments otherwise provided for by the Contract or these specifications.

Payment for this item includes all direct and indirect costs and expenses required to complete the work.

Pay items under this section include the following:

<b>Item No.</b>	<b>Pay Item</b>	<b>Unit</b>
1031100	MOBILIZATION – SUBCONTRACTOR	LS

**(6) SECTION 105: AUTOMATED MACHINE GUIDANCE:**

**A. GENERAL**

The use of Automated Machine Guidance (AMG) is required for the rough grading for this contract; however, the contractor may choose to use AMG on any operations (paving, fine grading, curb and gutter, etc.). This special provision describes the process required to ensure that the end results generated by equipment using AMG are in conformance with the tolerances required for conventional stakeout. This special provision is supplemental to Subsection 105.8 of the Standard Specifications.

Those areas not covered by this special provision are subject to the requirements of Subsection 105.8.

The Contractor is responsible for all errors resulting from the use of AMG. Correct all deficiencies to the satisfaction of the RCE at no additional cost to the Department.

**B. EQUIPMENT**

## EXHIBIT 5 – SPECIAL PROVISIONS AND CONTRACT REQUIREMENTS

Provide all equipment required to accomplish AMG. Use equipment that generates end results meeting the current Standard Specification for Highway Construction and all applicable supplemental specifications and special provisions.

### C. CONSTRUCTION

1. The Contractor shall provide electronic engineering data (EED) files to SCDOT prior to beginning construction. The files shall be generated with the computer software applications MicroStation (CADD software) and GEOPAK (civil engineering software). The EED files shall contain the following information and be in the native formats and other software formats as described below. The contractor will perform necessary conversion of the data files for the selected grade control equipment.

a. Survey Controls:

- 1) Control points
- 2) Bench marks
- 3) Project datum and scale factors

b. CADD Files:

- 1) MicroStation design file for plans, profiles, and other 2D linear features
- 2) MicroStation design files for cross sections
- 3) GEOPAK GPK file

c. Data Files:

- 1) Alignment Report
- 2) Cross Section Report
- 3) Horizontal Alignments in LandXML format
- 4) Vertical Alignments in LandXML format
- 5) Existing DTM in LandXML format
- 6) Proposed 3D surface model DTM files in in LandXML format
- 7) Proposed 3D break lines in DGN or DXF format

The Department assumes no risk or responsibility for any use of the EED files.

2. Where electing to use AMG, use the EED files to import and develop a 3D AMG model of the finish grade surface and break lines. Submit the 3D AMG surface in LandXML format and break lines in DGN or DXF format to the RCE. Submit a centerline and profile verification report that records differences between the developed 3D model and provided EED to the RCE. Provide the DOT representatives and RCE with a minimum of three hours of information exchange meeting and demonstrations about the 3D model builder software, work flow, data exchange, and quality control process. If the 3D AMG model is revised during construction, also submit the revised model to the RCE.

3. At least 14 days prior to use AMG, submit to the RCE a written AMG work plan which includes:

- a. Location and scope of work to be completed using AMG
- b. A description of the manufacturer, model, and control software version of the AMG equipment
- c. A description of how the proposed additional (new) project control points will be established and a map showing their locations
- d. Completed SCDOT Survey Control Plan Form
- e. Project site calibration procedures, including equipment calibration and calibration frequency
- f. A description of the setup of the GPS system, laser system, sonic systems, and/or robotic total stations to be used

## EXHIBIT 5 – SPECIAL PROVISIONS AND CONTRACT REQUIREMENTS

- g. Designation of a single staff person as the primary contact for GPS technology issues
  - h. PE or PLS seal and signature
4. Prior to use of AMG, construct a test section for work to be completed (in the final footprint of the roadway) with AMG to demonstrate to the RCE that the system has the capability to achieve acceptable results. Make the test section at least 500 feet in length. If acceptable results are not achieved, make necessary adjustments and rework the test section to the satisfaction of the RCE.
  5. Provide a GPS rover, including a data collector loaded with 3D models including surfaces, break lines, and alignments, with the same capabilities as units used by the Contractor for the RCE's use for the duration of the contract. The GPS rover unit will remain property of the Contractor. Provide the RCE and/or RCE's representatives with a minimum of eight hours of formal training on the use of the GPS rover unit and Contractor's AMG systems. Formal training will be provided by a manufacturer certified trainer and will include, but not be limited to, hardware, software, GPS localization/calibration, and operation of the rover unit.
  6. The RCE may perform spot checks of the machine control grading results, surveying calculations, records, field procedures, and actual staking as the RCE deems necessary. If the RCE determines the work is not being performed in a manner that will assure accurate results, the RCE may order such work to be redone to the requirements of the contract documents at no additional cost to the Department. At minimum, check, and if necessary, recalibrate the AMG system at the beginning of each work day and any time the results are suspected of being out of conformance with the specifications. Calibration results and out of tolerance checks will be provided to the RCE.
  7. Establish supplemental project control as needed for AMG operations. At minimum, establish secondary control points at appropriate intervals along the length of the project at intervals not to exceed 1000 feet. Establish the horizontal position of these points using methods where the relative horizontal accuracy meets the Class A Urban Survey accuracy standard (Standards of Practice Manual for Surveying in South Carolina). Establish the elevation of these control points using differential or trigonometric leveling from the project benchmarks with maximum allowable error of  $0.05\sqrt{L}$ , where L is the length of level run in miles. Provide a digital copy of all new control point information to the RCE. Department review of control point information in no way relieves the Contractor for responsibility for any and all errors resulting from their efforts. Correct all deficiencies to the satisfaction of the RCE at no additional cost to the Department.
  8. If the Contractor elects to use AMG for fine grading and placement of base or other roadway materials, use laser systems, sonic systems or robotic total stations-based AMG systems.
  9. Provide a clearly marked station stake at a minimum of every 500 feet on an offset from the edge of pavement as specified by the RCE.

### D. METHOD OF MEASUREMENT

The Contractor bears all costs, including but not limited to the cost of actual reconstruction of work, that may be incurred due to errors in application of AMG. Correction of grade elevation errors and associated quantity adjustments resulting from the Contractor's activities will be made at no cost to the Department.

### E. PAYMENT

The use of AMG is incidental to other project costs. No additional payment will be made for the use of AMG.

### (7) SECTION 106: PLANT/FABRICATOR INSPECTION:

Subsection 106.4, **Plant Inspection**, of the Standard Specifications shall be amended with the following:

**EXHIBIT 5 – SPECIAL PROVISIONS AND CONTRACT REQUIREMENTS**

Change the subsection title to **Plant/Fabricator Inspection** and add the following sentence after the first sentence:

“Provide 14 calendar days written notice to the Materials and Research Engineer prior to beginning fabrication work for Department projects.”

**(8) SECTION 106: QUALIFIED PRODUCT LISTINGS:**

All references to “Approval Sheet” or “Approval Policy” are to be replaced with “Qualified Products Listings (QPL)” and “Qualified Products Policies (QPP)” respectively. This change includes all references in the SCDOT Standard Drawings, SCDOT Standard Specifications, SCDOT Supplemental Specifications, SCDOT Special Provisions, SCDOT Supplemental Technical Specifications, SCDOT Internet and Intranet websites, and all other documents produced by SCDOT.

**(9) SECTION 106: SOUTH CAROLINA MINING ACT:**

The South Carolina Mining Act Supplemental Specification dated March 20, 2003 is hereby modified as follows:

Paragraph 9 is hereby deleted and replaced with the following:

The deputy secretary for engineering, or his duly appointed representative, will make a final inspection of the reclaimed area and keep a permanent record of his approval thereof. A map or sketch providing the location and approximate acreage of each pit used on the project will be provided to the resident construction engineer for inclusion in the final plans.

The last paragraph is hereby deleted and replaced with the following:

The contractor shall comply with the provisions of the plan that are applicable to the project as determined by the engineer. Seeding or other work necessary to comply with the plan on pits furnished by the contractor shall be at the expense of the contractor. Seeding shall be in accordance with SC-M-810 (latest version) which can be found at [http://www.scdot.org/doing/road\\_SupTechSpec.aspx](http://www.scdot.org/doing/road_SupTechSpec.aspx).

**(10) SECTION 107: FAIR LABOR STANDARDS ACT OF 1938, AS AMENDED:**

Attention is directed to this Federal Legislation, which has been enacted into law. The contractor will be responsible for carrying out all of the provisions of this legislation, which may affect this contract.

**(11) SECTION 107: CONTRACT PROVISION TO REQUIRE CERTIFICATION AND COMPLIANCE CONCERNING ILLEGAL ALIENS:**

By submission of this bid, the bidder as the prime contractor does hereby agree:

- A. to certify its compliance with the requirements of Chapter 14 of Title 8 of the S.C. Code of Laws regarding Unauthorized Aliens and Public Employment;
- B. to provide SCDOT with any documents required to establish such compliance upon request; and
- C. to register and participate and require agreement from subcontractors and sub-subcontractors to register and participate in the federal work authorization program to verify the employment authorization of all new employees, or to employ only workers who supply the documents required pursuant to S.C. Code 8-14-20(B)(2).

**(12) SECTION 107: IRAN DIVESTMENT ACT:**

By submission of this bid/proposal, the bidder/proposer as the prime contractor/consultant/vendor does hereby certify his compliance to the following:

- A. CERTIFICATION: (a) The Iran Divestment Act List is a list published pursuant to Section 11-57-310 that identifies persons engaged in investment activities in Iran. Currently, the list is available



at the following URL: <http://procurement.sc.gov/PS/PS-iran-divestment.phtm>. Section 11-57-310 requires the government to provide a person ninety days (90) written notice before he is included on the list. The following representation, which is required by Section 11-57-330(A), is a material inducement for the SCDOT to award a contract to you. (b) By signing your Offer, you certify that, as of the date you sign, you are not on the then-current version of the Iran Divestment Act List. (c) You must notify the SCDOT immediately if, at any time before posting of a final statement of award. You are added to the Iran Divestment Act List.

- B. ONGOING OBLIGATIONS: (a) You must notify SCDOT immediately if, at any time during the contract term, you are added to the Iran Divestment Act List. (b) Consistent with Section 11-57-330(B), you shall not contract with any person to perform a part of the Work, if, at the time you enter into the subcontract, that person is on the then-current version of the Iran Divestment Act List.
- C. OPTION TO RENEW RESTRICTION: Contractor acknowledges that, unless excused by Section 11-57-320, if the contractor is on the then-current Iran Divestment Act List as of the date of any contract renewal, the renewal will be void ab initio.

**(13) SECTION 107: MONITORING OF CONSTR.-RELATED EARTHBORNE VIBRATIONS:**

July 8, 2015

**A. DESCRIPTION**

The project construction will generate vibrations that will travel through the earth, which will subsequently be received or “sensed” by nearby structures and inhabitants. Specific procedures that will generate earthborne vibrations during bridge and roadway construction include (but are not limited to) the installation of piles, earthquake drains, shoring walls, general foundation construction, and vibratory compaction of unclassified or borrow excavation. To mitigate the risk of vibration-related damage to nearby structures, this specification outlines the Contractor’s responsibility for performing a program of pre-construction condition assessment and vibration monitoring during construction.

This specification is based, in part, on AASHTO R 8-96 (2004) *Standard Recommended Practice for Evaluation of Transportation-Related Earthborne Vibrations*. As discussed in AASHTO R 8-96 (2004), humans respond to a much broader range of vibration frequencies and intensities than structures. Intrusive vibration levels can annoy humans at much lower intensities than levels considered critical for structures. Thus, occupants of adjacent properties may perceive that the construction-induced vibrations may present risk to their structures. The recommended safe vibration limits are intended to mitigate the risk of structure damage, and more specifically, reduce the development of “threshold cracks” or cosmetic cracking. Such cracks may appear at lower vibration levels than the level at which architectural or minor structural damage would be expected to occur.

**B. PRE-CONSTRUCTION CONDITION ASSESSMENT**

The Contractor shall retain a geotechnical engineering firm to perform a pre-construction condition assessment to document the conditions of nearby buildings and other sensitive nearby structures prior to the beginning of construction. The assessment shall be performed on all properties adjacent to the project site and any other properties as directed by the Engineer. The assessment shall include any structures within 300 feet of any vibration inducing construction activity. The assessment should include video and photographic documentation of all exteriors and interiors, and installation of crack monitors on cracks that might propagate due to construction vibrations. All documentation of existing building conditions and information concerning the type and location of crack monitors shall be presented to the Engineer in a report prior to construction.

**C. CRACK MONITORING DURING CONSTRUCTION**

During all construction, the Contractor shall perform periodic readings of the crack monitors that were installed during the pre-construction condition assessment. All readings shall be provided to the Engineer within 48 hours of taking the reading. Provided that the crack readings confirm that vibrations are not contributing to increasing the crack width, the crack monitors may be read

once per week. More frequent readings may be directed by the Engineer during activities that are expected to have greater earthborne vibrations (e.g., pile driving). If the crack readings suggest that vibrations from the project site are contributing to crack width, then the Contractor shall immediately notify the Engineer and review those activities that are generating the earthborne vibrations. The Contractor and his or her geotechnical firm shall then submit a detailed plan for repair, perform the repair at no cost to the Department and develop and submit for review a revised construction plan to address the vibration problems and minimize further damage and complaints.

**D. VIBRATION MONITORING DURING CONSTRUCTION**

1. Procedure - The Contractor shall monitor vibrations at no less than four locations at each specific site of construction activity along the perimeter of the project during all foundation and embankment construction activities. The locations shall be selected by the Contractor based on the location of the construction activities and their relative position to nearby offsite structures. Prior to construction, a plan of the monitoring locations shall be submitted to the Engineer for acceptance. The locations of the vibration monitors shall be adjusted during construction with acceptance by the Engineer. The vibration monitors shall be established at the site so that background vibrations may be determined prior to beginning foundation or embankment construction. The sensitivity range of the seismograph shall be selected so that the recording is initiated below the maximum allowable particle velocity shown in Figure 1 and extends above the highest expected intensity. Specific activities of the vibration source shall be indexed in time to allow correlation with the arrivals on the vibration
2. Project Vibration Criteria - The maximum allowable particle velocity is shown in Figure 1. If the data from the monitors indicate that vibrations are exceeding the established criteria, then the Contractor shall immediately notify the Engineer and suspend those activities which are generating the earthborne vibrations, until the Contractor and his or her geotechnical firm have developed a revised construction plan to resolve the problem. The problem shall be resolved at no additional cost to the Department.
3. Instrumentation – The vibration monitors shall consist of digital seismographs that display the particle velocities and associated frequencies plotted against the criteria for this project (i.e., Figure 1). Each seismograph shall contain geophones with response capability in three mutually perpendicular axes or components: one vertical and two horizontal (radial and transverse). The frequency response of the geophones shall be linear from at least 4 Hz to more than 200 Hz. The sensitivity shall range from less than 0.02 in/sec to more than 5.0 in/sec. The BlastMate III by InstanTel is one type of seismograph that is suitable for this project.
4. Calibration and Instrument Use - The Contractor shall field calibrate the vibration monitors before the start of each recording period. The transducer shall be positioned with the longitudinal axis toward the vibration source. Transducers must be adequately coupled with the ground. Operation of all vibration monitors shall be in accordance with the instrument manufacturer's instructions and recommendations. Vibration records shall be collected in waveform plot or strip chart plot. The peak vector sum of the particle velocity in longitudinal, transverse, and vertical planes shall be shown along with the respective dominant or principle frequencies. The highest recorded particle velocity (i.e., the vector sum of the three orthogonal directions), when indexed to a particle vibration event, shall be reported as the peak particle velocity. The recorded peak particle velocity shall be compared to criteria appropriate for the subject of concern.
5. Complaints - In the event of a complaint, the Contractor shall immediately contact the Engineer and review those construction activities that are inducing vibrations into the earth. The Contractor shall prepare a report documenting all relevant data such as the time and date presented in the complaint, a description of the construction activities during the subject time/date, data from the monitoring instruments for the subject time/date, complaint information and a description (including photographs, if possible) of the alleged damage. The Contractor and his or her geotechnical firm shall then submit a detailed plan for repair, perform the repair at no cost to the Department and develop and submit for review a revised

**EXHIBIT 5 – SPECIAL PROVISIONS AND CONTRACT REQUIREMENTS**

construction plan to address the vibration problems and minimize further damage and complaints.

**E. METHOD OF MEASUREMENT**

In addition to the pre-construction condition assessment report, the Contractor shall also provide monthly reports containing the results of the crack monitors and vibration monitors during those activities that generate earthborne vibrations, including (but not limited to) ground improvement and foundation construction. The reports shall document that the Contractor is providing the work described by this specification.

**F. BASIS OF PAYMENT**

Payment shall be made in proportion with the percent of the project that is complete. Final payment of the remaining lump sum balance shall be made when vibration monitoring is complete as approved by the Engineer. Payments shall be made under:

Item No.	Pay Item	Pay Unit
1075001	MONITORING OF CONSTRUCTION-RELATED EARTHBORNE VIBRATIONS	LS

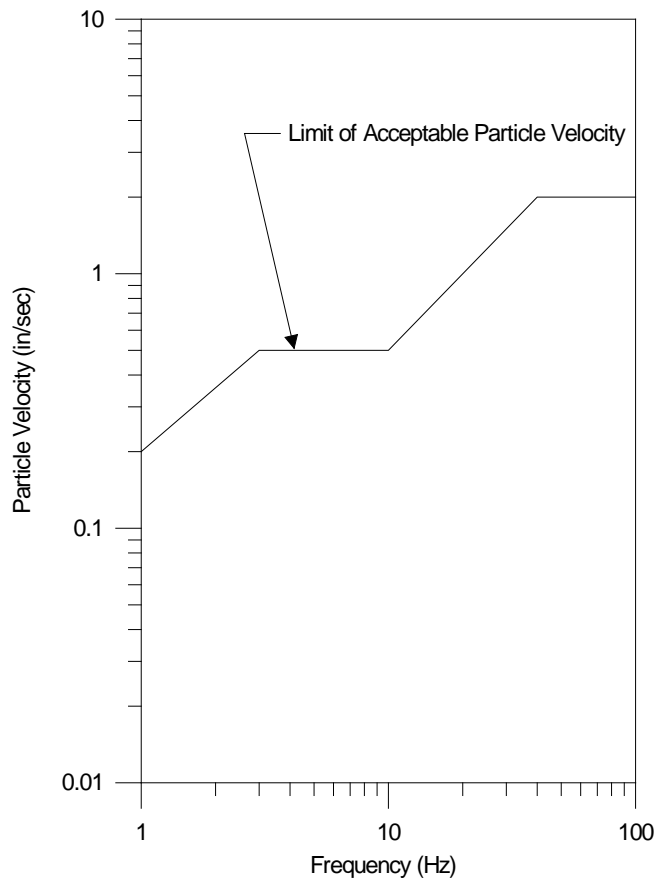

Figure 1 - Vibration Criteria (adapted from AASHTO R8-96)

**(14) SECTION 107: COMMUNITY AND PUBLIC RELATIONS PLAN:**

SCDOT will take the lead role on this project and be responsible for a portion of the public information efforts. Unless noted otherwise elsewhere in this RFP, the SCDOT responsibilities include:

## EXHIBIT 5 – SPECIAL PROVISIONS AND CONTRACT REQUIREMENTS

- A. Developing and maintaining the project website
- B. Soliciting and administering advertisements and media announcements, as deemed necessary

The Contractor shall coordinate with the Department to promote public awareness for this project. The amount of public involvement required for this project is directly based on the Contractor's Transportation Management Plan and construction details. The Design- Build Team's responsibilities shall include:

- A. Providing details surrounding the impacts to the public
- B. Providing advance notice to the Department of upcoming project impacts
- C. Assisting the Department in the development of the target audience list
- D. Attending and/or speaking at public meetings
- E. Hand delivery of time sensitive informational materials
- F. Preparing advertisements and media announcements
- G. Preparing and forwarding direct mailers, flyers, and other promotional materials as necessary
- H. If required, organizing public meetings, including venue selection, reservation and fee

The Contractor shall hold an initial project coordination meeting with SCDOT at least one month prior to start of construction to discuss project impacts to the public. This information will be used by the Contractor to create a Public Information Plan.

The Contractor shall inform the Department at least twenty-one (21) calendar days in advance of any construction activity that will have significant impact on the public, including, but not limited to, the start of construction, major traffic shifts, road closures, ramp closures, detours, night work and project completion.

The Contractor will develop, with the assistance of SCDOT, the specific list of target audiences for this project. The following groups are identified as typical target audiences to receive informational materials:

- A. State Senator(s) and Representative(s)
- B. Chairman of the County Council
- C. County Administrator/Manager
- D. County Planner
- E. City Mayor (as appropriate)
- F. City Manager (as appropriate)
- G. Transportation services
- H. Emergency services
- I. Neighborhood groups and private homes
- J. Industry and businesses
- K. Chamber(s) of Commerce
- L. Individual schools effected by the project
- M. Public School District(s) and Transportation Office(s)
- N. Post Office
- O. Any other organization as deemed necessary by the Department

The minimum public information requirements solely associated with the Transportation Management Plans shall include, but not be limited to the following:

Public Meetings - If Beginning of Construction meeting for area businesses and residents is held, attending and I or speaking at this event.

Distribution of Informational Materials - For beginning of construction and for all road closures with detour routes, the Contractor shall be responsible for delivering time sensitive informational material provided by the SCDOT directly to portions of the target audience. If the Contractor informs the Department of the aforementioned activities less than twenty-one (21) calendar days in advance, the Contractor shall hand deliver the informational materials to the impacted target audiences.

**EXHIBIT 5 – SPECIAL PROVISIONS AND CONTRACT REQUIREMENTS**

The Department will be responsible for establishing, creating, maintaining and updating the project website for this project. However, throughout the project duration, the Contractor shall coordinate with the RCE to ensure the accuracy of the aforementioned project website. At a minimum, the Contractor shall designate a contact for public information inquiries and coordination. Throughout construction, at a minimum, this contact shall provide bi-weekly updates to the RCE, including, but not limited to, traffic control phasing, graphic illustrations, project pictures, etc.

The Contractor shall include in their Total Cost to Complete, all costs associated with their involvement in the Community and Public Relations Plan.

**(15) SECTION 108: PARTNERING:**

**A. COVENANT OF GOOD FAITH AND FAIR DEALING**

This Contract imposes an obligation of good faith and fair dealing in its performance and enforcement. The CONTRACTOR and Department, with a positive commitment to honesty and integrity, agree to the following mutual duties:

1. Each will function within the laws and statutes applicable to their duties and responsibilities.
2. Each will avoid hindering the other's performance.
3. Each will proceed to fulfill its obligations diligently.
4. Each will cooperate in the common endeavor of the Contract.

**B. PARTNERING**

The Department encourages the foundation of cohesive partnering with the CONTRACTOR and its principle subcontractors and suppliers. This partnering is not a legal partnership as defined by South Carolina law. Partnering will be structured to draw on the strengths of each organization to identify and achieve reciprocal goals. The objectives are effective and efficient contract performance and completion within budget, on schedule, and in accordance with the Contract.

The establishment of a partnering charter will not change the legal relationship of the parties to the contract nor relieve either party from any of the terms of the Contract. Any cost associated with effectuating partnering will be agreed to by the Department and the CONTRACTOR and will be shared equally between them.

**(16) SECTION 109: REFERENCES TO UNIT PRICING:**

Any references in the contract documents to unit price, measurement, and payment, are typical references for design-bid-build contracts and are not applicable to the extent they effect payment on Design-Build contracts. The Design-Build contractor's schedule of values shall provide sufficient detail to compare work progress to the contractor's schedule and determine appropriate periodic payments.

**(17) SECTION 109: FUEL ADJUSTMENT INDEXES:**

The Fuel Adjustment Indexes Supplemental Specification dated December 1, 2009 applies to this project. For this project the diesel fuel and unleaded gasoline indexes will be determined on the first calendar day of the month in which this project is let. The indexes and price adjustment tables will be available on the internet at [http://www.scdot.org/doing/constructionLetting\\_MonthlyIndex.aspx](http://www.scdot.org/doing/constructionLetting_MonthlyIndex.aspx), or from the office of the Contracts' Administrator.

The following items are hereby included in the table entitled "Items of Work Eligible for Fuel Adjustments" in the Supplemental Specification:

Smooth Wall Pipe (24" or less)	Gallons/LF	0.50	0.15
Smooth Wall Pipe (greater than 24")	Gallons/LF	0.75	0.15
Corrugated Wall Pipe (24" or less)	Gallons/LF	0.50	0.15

<b>EXHIBIT 5 – SPECIAL PROVISIONS AND CONTRACT REQUIREMENTS</b>			
---	--	--	--

Corrugated Wall Pipe (greater than 24")	Gallons/LF	0.75	0.15
---	------------	------	------

The following Section of the Supplemental Specification is hereby modified:

Additional Provisions:

The Department will calculate and apply fuel adjustments to estimates based on index values set at the beginning of the estimate period.

Estimate period begins on the 1st of the month and ends on the last day of the month. The 1st of the month Index will be compared to the contract Base Index to determine index adjustments for the estimate period.

**(18) SECTION 202: RECLAIMING EXISTING ROADWAY:**

**A. DESCRIPTION**

This work consists of the restoration of paved areas. These areas are typically shown as hatched areas on the plans when outside the construction limits.

**B. MATERIALS**

None

**C. CONSTRUCTION REQUIREMENTS**

1. Asphalt Pavement with Earth Base: Remove and dispose of areas of pavement shown as hatched areas on the plans. Grade the area to properly drain. Seed the area in accordance with Section 810.
2. Asphalt Pavement with Stone Base: Remove and dispose of areas of pavement and base shown as hatched areas on the plans. Grade the area to properly drain. Seed the area in accordance with Section 810.
3. Earth roadway or Bituminous Surfacing with Earth Base: Scarify existing areas of roadway. Grade the area to properly drain. Seed the area in accordance with Section 810.
4. Bituminous Surfacing with Stone Base: Remove and dispose of areas of pavement and base shown as hatched areas on the plans. Grade the area to properly drain. Seed the area in accordance with Section 810.

Suitable materials may be used for embankment construction on the project. In the event that removed materials are used for embankment construction a corresponding deduction in Unclassified Excavation will be made by the Resident Construction Engineer.

**D. MEASUREMENT**

Removed asphalt pavement greater than 2 inches in depth will be measured by the square yard. Removed bituminous surfacing with stone base will be measured by the cubic yard. Removed stone base will be measured by the cubic yard. Scarified areas will not be measured for payment.

**E. PAYMENT**

Removed asphalt pavement which is greater than 2 inches in depth will be paid at the unit price bid for Removal and Disposal of Existing Asphalt Pavement. Removed bituminous surfacing with stone base will be paid for at the unit price bid for Unclassified Excavation. Removed stone base will be paid for at the unit bid price for Unclassified Excavation. No payment will be made for scarifying earth roadway or bituminous surfacing with earth base. No separate or additional payment will be made for grading necessary to obtain proper drainage.

**(19) SECTION 202: REMOVAL OF EXISTING GUARDRAIL:**

Section 202.4.4.3 applies on this project.

**(20) SECTION 203: MUCK EXCAVATION:**

September 19, 2011

Section 203.2.1.3 is amended as follows:

Any areas identified on the plans and any additional areas defined by the RCE that are discovered to deflect or settle may require corrective action by the Contractor. This may include undercutting, placing granular aggregate, placing stone aggregate that is separated from other fine aggregate materials by a geotextile for separation of sub-grade and sub-base, and/or additional compacting to the approval of the Engineer.

In areas that require mucking or undercutting, borrow excavation soil may be placed as a bridge lift as long as the grade on which the material is being placed is at least 2 feet above ground water level. In the event that groundwater does not allow backfilling with a borrow excavation soil, a stone or granular material shall be used as the bridge lift material. This stone or granular material shall be in accordance with the Bridge Lift Materials Special Provision. Stone bridge lift materials shall have a thickness of 2 feet and shall extend a minimum of 6 inches above the ground/surface water level. Granular lift materials shall also have a thickness of 2 feet, but shall extend a minimum of 2 feet above ground/surface water level. Individual granular bridge lifts shall not exceed a 2-foot thickness without some type of limited compactive/tamping effort. The depth at which mucking or undercutting shall take place is dependent upon encountering a suitable bearing material within the excavation or a predetermined elevation or depth. In most cases, undercutting shall not exceed 3 to 5 feet in depth, but the final mucking or undercutting thickness shall be based on the decision of the RCE, unless otherwise specified in the project plans and/or specifications. If a suitable bearing soil is not encountered within this depth range or unless otherwise specified in the plans and/or specifications, a P1 biaxial geogrid with an aperture size of less than or equal to 1 inch shall be placed beneath the stone or granular bridge lift material. The geogrid shall be placed in the bottom of the excavation and up the excavation side slopes. If additional compacted borrow excavation soil is needed to reach grade, a geotextile for separation of sub-grade and sub-base shall be placed between any stone bridge lift material and the overlying compacted soil. A bridge lift, consisting of borrow excavation soil or granular bridge lift material, should not be placed within 3 feet of the base of the pavement section. Only compacted borrow excavation soil or stone bridge lift material shall be placed within this zone. The biaxial geogrid shall be in accordance with the Special Provision provided in the project documents.

The quantities associated with mucking and undercutting, i.e. mucking, stone and granular bridge lift materials, geogrid, and geotextile for separation of sub-grade and sub-base, are for bid estimation purposes only. These bid items shall not be purchased and stockpiled on site without written approval from the RCE unless specific areas and details are defined in the plans

## EXHIBIT 5 – SPECIAL PROVISIONS AND CONTRACT REQUIREMENTS

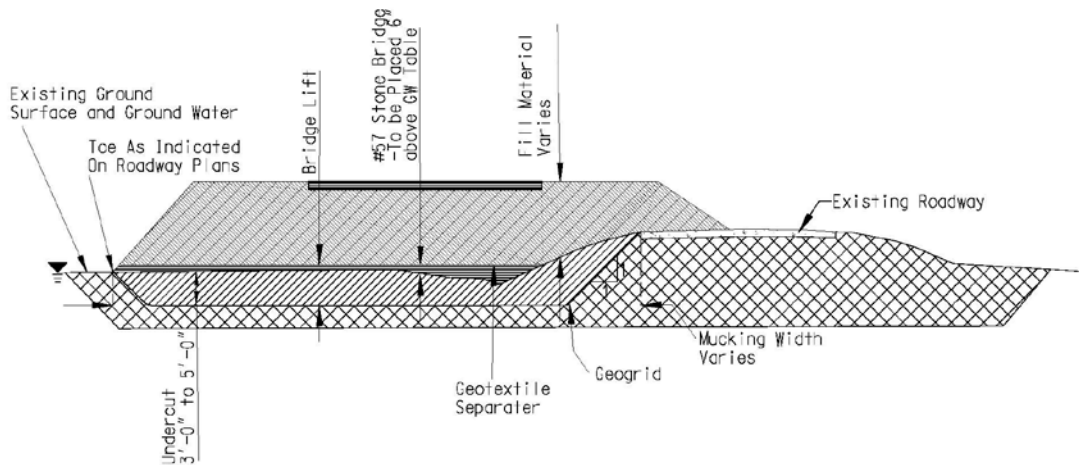

**UNDERCUT, GEOGRID, AND STONE BRIDGE LIFT**

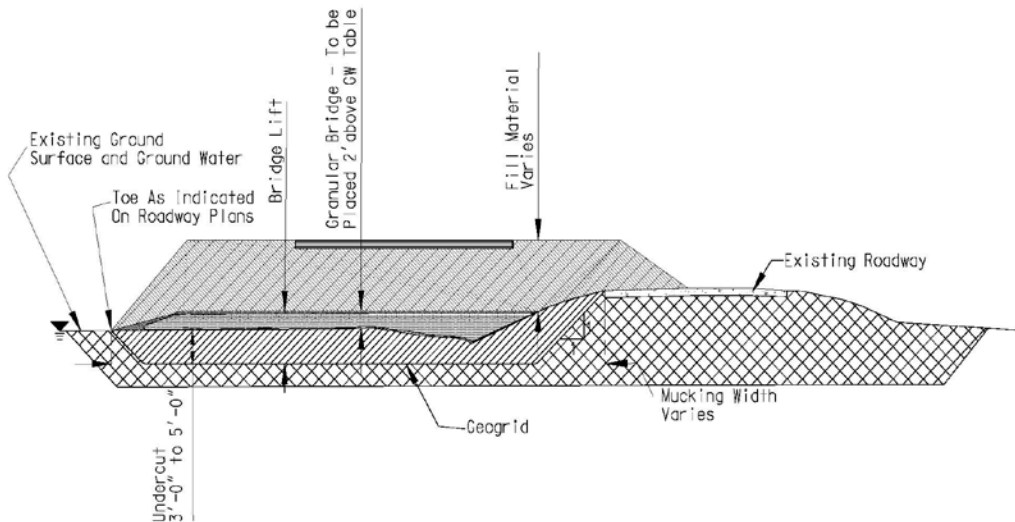

**UNDERCUT, GEOGRID, AND GRANULAR BRIDGE LIFT**

### (21) SECTION 203: BORROW EXCAVATION:

March 6, 2013

Section 203.2.1.8 of the Standard Specifications is amended as follows:

Ensure that all borrow material placed on embankments meet or exceed the requirements for total and effective internal friction angle, cohesion, and total moist unit weight as specified by the geotechnical design engineer of record. These requirements shall be determined by the following tests:

- Internal friction angle determined from either direct shear (AASHTO T236) or triaxial (AASHTO T297) testing on remolded specimens performed by the Contractor.
- Cohesion determined by triaxial (AASHTO T297) testing on remolded specimens performed by the Contractor.
- Total moist unit weight determined by standard proctor test (AASHTO T99) on remolded specimens performed by the Contractor.



## EXHIBIT 5 – SPECIAL PROVISIONS AND CONTRACT REQUIREMENTS

Remold all samples to 95 percent of the maximum dry density as determined by the Standard Proctor test (AASHTO T99) and test at normal/consolidation stresses specified by the geotechnical design engineer of record. Conduct shear strength and soil classification testing (AASHTO M145) at the initial selection of the borrow pit, any subsequent changes in borrow pits, and for every 50,000 cubic yards of materials placed. This testing is in addition to the normal embankment and borrow sampling and testing requirements for classification and compaction in accordance with Section 205 of the SCDOT Standard Specifications for Highway Construction that are used for daily acceptance.

Perform additional shear strength testing and/or soil classification testing at no additional cost to the Department when the Department deems that the materials being placed appear to be different from those originally tested. Submit all test results to the RCE for approval prior to use in embankment construction. The RCE will also submit copies of the test reports to the Quality Assurance Engineer at the Office of Materials and Research. Use only qualified laboratories that are appropriately accredited by AASHTO to perform the test procedures required by this specification.

Do not use material derived from Unclassified Excavation to construct embankments unless that material meets the requirements for Borrow Material as stated above.

### **(22) SECTION 203: BORROW EXCAVATION (FOR SHOULDERS):**

This work shall consist of satisfactory placement of all materials necessary to bring the shoulder grade to within 2 inches of the final pavement edge grade. The Contractor shall furnish all earth material necessary to eliminate any edge of final pavement to shoulder gradient differential that exceeds 2 inches. The quantities shown on the plans are the Engineering estimate of the number of units that will be necessary for this project, actual field measurements may cause these quantities to vary.

Selected materials shall be used for this operation. The selected material shall consist of a friable material such as topsoil, etc., containing grass roots and having the properties of being comparatively porous, capable of growing grass and of a stable nature in that when compacted it will resist erosion and be capable of supporting vehicles when relatively wet. When the area where material is to be placed, is greater than 4 feet in width, it shall be scarified and/or disked to a minimum depth of 3 inches prior to placing any material. Scarifying or disking is not required for areas less than 4 feet in width. Borrow shall be mixed with the existing scarified and/or disked shoulder material in such a manner as to provide a seed bed in accord with Section 810.15 of the Standard Specifications. The Contractor has the option of placing the borrow material (a) Prior to placing final surface course or (b) Following the placing of the finished surface course.

The method of measurement will be the volume in cubic yards, determined in accordance with Section 203 of the Standard Specifications. The Contractor, at his option, may elect to base the quantity measured on the loose volume at the point of delivery by scaling and counting the loads, with a deduction of 35 percent made for shrinkage. All cost for borrow material including obtaining, hauling, and placing shall be included in the unit price.

### **(23) SECTION 203: BORROW PITS:**

#### **A. PERMITTING OF BORROW PITS**

Prior to using borrow material from commercial or other borrow pits located wholly or in part in wetland areas, the contractor shall submit written evidence that operations to obtain fill material from the borrow pit(s) have received all appropriate and necessary authorizations from federal, state, and/or local authorities.

Permitted Borrow Pits

If the appropriate federal, state, and local authorities have issued permits, the contractor shall provide to SCDOT copies of all permits issued for such borrow pit sites.

#### **B. BORROW PITS WITHOUT SECTION 404 PERMIT**

## EXHIBIT 5 – SPECIAL PROVISIONS AND CONTRACT REQUIREMENTS

For borrow pit sites for which a Section 404 permit under the Clean Water Act has not been issued, the contractor shall provide SCDOT with copies of documentation provided by the contractor or its subcontractor(s) to the U.S. Army Corps of Engineers, which shall, at a minimum, clearly define the location of the borrow pits and any wetlands on the borrow pit site; describe the proposed activities and processes that will be used to prepare the site, obtain fill material from the site, and store material at the site; and request the U.S. Army Corps of Engineers to confirm in writing that no Section 404 permit is required for those operations. No operations shall take place at the borrow sites for at least thirty days from the date of the submission of confirmation request to the U.S. Army Corps of Engineers. After thirty-one days the contractor may begin work. The contractor shall also provide copies to SCDOT of any response(s) provided by the U.S. Army Corps of Engineers to its documentation.

### **C. RESPONSIBILITY**

SCDOT has no obligation or duty to review, assess, evaluate, or act upon such documentation and maintains no authority or responsibility to alter, amend, reject, accept, or otherwise exercise any control over the contractor or subcontractor regarding compliance with Clean Water Act Section 404 and the implementing regulations for Section 404. Documentation submitted to SCDOT is for public information and coordination purposes only. The contractor is responsible for all costs related to the selection, operation, and/or activities at any borrow pit site in wetlands including fines, additional mitigation, and impact delays related to failure to obtain any and all necessary federal, state, and local permits and approvals for borrow pits and operations. Nothing herein shall affect in any way SCDOT's right to accept or reject any fill material not meeting the required technical specifications.

### **(24) SECTION 204: TEMPORARY SHORING WALL:**

Subsection 204.4.5.2 of the Standard Specifications is amended to include the addition of the following section:

"The retaining wall system shall be designed to limit deformations (vertical and lateral displacements) that would affect the stability or performance of any adjacent structures (MSE walls, Bridge foundations, Pavement Structure, Approach Slabs, Embankment (stage construction), etc.). Deformations that must be limited shall include, but not be limited to, vertical settlement, sliding, bulging, bowing, bending, and buckling. Design criteria for allowable deformations shall be dependent on the type of structure that will be influenced by any deformation of the temporary shoring wall. Regardless of the type of structure being retained, the deformation criteria shall not exceed 3 inches without acceptance from the Geotechnical Design Support Engineer. An instrumentation plan for monitoring deformations of the temporary shoring and any adjacent structure shall be submitted along with the shop drawings. The instrumentation plan shall indicate the maximum allowable deformations of the temporary shoring and adjacent structures. Typical instrumentation used for monitoring deformations are survey targets, settlement monuments, crack gages, inclinometers, and tilt monitors. The monitoring locations shall be established in a manner that they can be monitored consistently and obtain repeatable measurements for the entire construction period. A monitoring schedule that the Contractor will use during construction will also be included with the instrumentation plan. The Contractor shall submit periodic monitoring reports to the RCE in accordance with the approved instrumentation plan. Any changes in frequency of monitoring or report submittal must be sent to the Geotechnical Design Support Engineer for acceptance. If the initial instrumentation plan is found not to be documenting adequately the movements of the temporary shoring or adjacent structures, the Contractor will revise the instrumentation plan and resubmit the revised plan for review and acceptance. If the measured deformations exceed the maximum allowable deformations shown in the instrumentation plan, the Contractor will be required to stop work immediately, and at his own expense, correct the situation to the satisfaction of the Department prior to resumption of construction activities. Extended monitoring after construction may be required if adjacent structures have been affected by the construction. The extended monitoring of the adjacent structures shall continue until the structures have stabilized and the Department concurs with the results and conclusions of the monitoring report. All costs associated with developing the instrumentation plan, purchasing instrumentation, installing

**EXHIBIT 5 – SPECIAL PROVISIONS AND CONTRACT REQUIREMENTS**

instrumentation, and monitoring of the instrumentation shall be included in the unit cost of the temporary shoring item.”

**(25) SECTION 205: LIGHTWEIGHT AGGREGATES:**

July 23, 2010

**A. DESCRIPTION**

This work shall consist of furnishing, loading, hauling, placing and compacting lightweight aggregates (either man-made or natural) for use as fill materials in accordance with these specifications. The lightweight aggregate must be manufactured by expanding shale, clay, or slate in a rotary kiln operation or be naturally made. Wood fiber, blast furnace slag, fly ash, shredded tires, or boiler slag will not be allowed. The material must be sub angular to angular conforming to ASTM C 330 (latest edition). The material requirements presented in this specification are appropriate for borrow materials placed in embankments or placed as retained materials. If lightweight aggregates are used as reinforced backfill materials for the construction of Mechanically Stabilized Earth (MSE) walls or other reinforced soil structures, additional material properties, construction, and testing frequency requirements may be required based on the appropriate specifications.

**B. MATERIAL**

The Lightweight aggregate must have a proven record of durability, be non-corrosive, and conform to the following requirements:

1. pH (AASHTO T-289): pH values shall range between 5 and 10.
2. Organic Content (AASHTO T-267): Organic content shall be less than 0.1 percent (weight of organic material to weight of total sample).
3. Soundness Loss (AASHTO T104): Soundness loss shall be less than 15% when subjected to 5 cycles of Sodium Sulfate.
4. Los Angeles Abrasion (AASHTO T96): Abrasion loss shall be less than 45%.
5. Chloride Content (AASHTO T291): Chloride content shall be less than 100 ppm.
6. Sulfate (AASHTO T-290): Sulfate content shall be less than 200 ppm.
7. Resistivity (ASTM D1125): Resistivity must be greater than 3000-ohm-cm. If resistivity is greater than 5000-ohm-cm, chloride and sulfate requirements and testing are waived.
8. Absorption (AASHTO T19): Absorption must be less than 6%.
9. Gradation (ASTM 136): The gradation will be as shown in the following Table. Other gradations may be acceptable upon approval by the Engineer.

Table – Lightweight Aggregate Gradation

Sieve Size or Number	Percent Passing
¾ inch	100
½ inch	90 – 100
3/8 inch	50 – 90
No. 4	0 – 50
No. 8	0 – 20
No. 16	Less than 10
No. 30	Less than 10
No. 50	Less than 5
No. 100	Less than 5

10. The coefficient of uniformity,  $C_u$ , shall be 4 or greater. The coefficient of uniformity,  $C_u$ , shall be computed as follows:

**EXHIBIT 5 – SPECIAL PROVISIONS AND CONTRACT REQUIREMENTS**

$$C_u = \frac{D_{60}}{D_{10}}$$

Where  $D_{60}$  is the particle diameter at 60% passing and  $D_{10}$  is the particle diameter at 10% passing. Written approval from the DOC will be required to use soils with a coefficient of uniformity,  $C_u$ , less than 4.

11. Aggregate loose unit weight (ASTM C29): The loose unit weight must be less than 45 lbs/ft<sup>3</sup>.
12. In-place density: (ASTM D4253, and D4254): The in-place compacted dry unit weight must be between 55 and 60 lbs/ft<sup>3</sup>. Material must be compacted to a minimum 65% relative density as determined by ASTM D4253 and D4254. Use a vibratory table when determining the maximum index density and unit weight in accordance with ASTM D4253. Determine the minimum index density and unit weight in accordance with ASTM D4254.
13. Angle of Internal Friction (AASHTO T 236): The minimum angle of internal friction must be 40 degrees. Test a saturated representative sample (with particles larger than 0.75 inch removed) in a round or square shear box that is a minimum of 12 inches across. Test sample shall be compacted to a minimum 65% relative density as determined by ASTM D4253 and D4254.

**C. CONSTRUCTION**

Place the lightweight fill in uniform layers. When required by the Engineer, compact each layer using vibratory compaction equipment weighing no more than 10 tons. Place layers no more than 12 inches in depth loose thickness and compact. Compact with three passes of an 8 – 10 ton vibratory roller in the vibratory mode if necessary, or as directed by the Engineer. In confined areas use vibratory plate compaction equipment (5 hp to 20 hp) with a minimum of two passes in 6" lifts for a 5 hp plate and 12" lifts for a 20 hp plate. The contractor must take all necessary precautions when working on or near the lightweight fill to ensure that the material is not over compacted. Construction equipment, other than for placement and compaction, must not operate on the exposed lightweight fill. Low ground pressure equipment (D6 LGP or lighter) is recommended for spreading and placing the lightweight aggregate.

**D. TESTING FREQUENCY**

All soil property requirements shall be tested during initial source evaluation or if a change in source is requested. Lightweight aggregate material shall be sampled once every 2,000 cubic yards and tested for gradation and pH. Lightweight aggregate material shall be sampled once every 5,000 cubic yards and tested for internal friction angle, organic content, resistivity, chloride content, and sulfate content. Chloride and sulfate content testing will not be required if resistivity test results indicate 5000 ohm-cm or greater. The internal friction angle shall be tested every 2,000 cubic yards if the gradation indicates that the coefficient of uniformity,  $C_u$ , is less than 4. A variation in testing frequency may be required if a variation in material gradation or composition is observed.

**E. MEASUREMENT AND PAYMENT**

Measurement of lightweight aggregate shall be the actual volume in-place at the project site. All costs for furnishing, loading, hauling, placing and compacting lightweight aggregates (either man-made or natural) shall be included in the unit price of the lightweight aggregates.

Payment will be made under:

Item No.	Pay Item	Pay Unit
2033020	BORROW EXCAVATION (LIGHTWEIGHT)	CY

**(26) SECTION 205: HIGH-STRENGTH GEOTEXTILE FOR EMBANKMENT REINFORCEMENT:**

April 21, 2015

**A. DESCRIPTION**

Project ID P028843	Page 20
--------------------	---------

## EXHIBIT 5 – SPECIAL PROVISIONS AND CONTRACT REQUIREMENTS

This work shall consist of furnishing and installing construction geotextiles in accordance with the details shown in the plans, specifications, or as directed by the RCE.

### B. MATERIALS

A geotextile is defined as any permeable polymeric textile used with foundation, soil, rock, earth, or any other geotechnical engineering related material, as an integral part of a civil engineering project, structure, or system. Use geotextiles and thread used in joining geotextiles manufactured from fibers consisting of long-chain polymers, composed of at least 95 percent by weight of polyolefins or polyesters. Use geotextiles with fibers formed into a stable network such that the fibers or yarns retain their dimensional stability relative to each other, including selvages (edges) during shipping, handling, placement, and in service. Use geotextile free from defects or tears.

1. **Minimum Average Roll Values:** All property values, with the exception of Apparent Opening Size (AOS), represent Minimum Average Roll Values (MARV) in the weakest principal direction. Provide geotextiles whose average test results from any roll sampled in a lot for conformance or quality assurance testing meets or exceeds minimum values provided in this Section.
2. **Apparent Opening Size:** Values for Apparent Opening Size (AOS) represent maximum average roll values. Acceptance will be based on ASTM D 4759.
3. **Reinforcement Geotextile:** Use reinforcement geotextile within existing and/or proposed fills for slope reinforcement.

Furnish geotextiles meeting the property requirements outlined in Table 1.

Table 1: High Strength Geotextile Properties (Design Requirements)<sup>1,2</sup>

Property	Test Method	Geotextile Property Requirements
Long-Term Design Strength, $T_{al}$ , MD		22,800 lb/ft
Long-Term Design Strength, $T_{al}$ , XD		2,280 lb/ft
Sewn Seam Breaking Strength <sup>3</sup>	ASTM D4884	900 lbs/ft
AOS	ASTM D4751	$\leq (1.0 \text{ to } 2.0)D_{85(\text{soil})}$
Permeability	ASTM D4491	$\geq 10k_{\text{soil}}$
Default Pullout Friction Factor, $F^*$	ASTM D6706	$0.6 \tan \Phi$
Default Alpha, $\alpha$	ASTM D6706	0.6
Ultraviolet Stability	ASTM D4355	$\geq 50\%$ after 500 hrs of exposure

- Notes:
1. The test procedures shall conform to the most recently approved ATSM geotextile test procedures.
  2. All numeric values represent Minimum Average Roll Value (MARV).
  3. Applies to factory or field sewn seams.

#### 4. Source Approval and Certification

Prior to construction, the Contractor shall submit to the Resident Construction Engineer (RCE) a Certification Package prepared by the geotextile reinforcement manufacturer. The Contractor shall allow 21 calendar days from the day the submittals are received by the RCE for review and acceptance. Submit the following information regarding each geotextile proposed for use:

- a. Manufacturer's name and current address;
- b. Full product name/number, including roll number;
- c. Geosynthetic material (i.e. polymer type) and structure (including fiber/yarn type);
- d. Proposed geotextile use(s); and
- e. Certified test results for the properties outlined in Table 1 and below in Section 4.

## EXHIBIT 5 – SPECIAL PROVISIONS AND CONTRACT REQUIREMENTS

The Certification shall state that the furnished geotextile soil reinforcement is in full compliance with the design requirements as stated in this specification and the design drawings and is fit for use in long-term critical soil reinforcement applications. In addition to the minimum required properties in Table 1, the submittal shall also certify the following values for each geotextile soil reinforcement used on the project:

- a. The ultimate tensile strength,  $T_{ULT}$ , (MARV) for geogrid soil reinforcements, MD/XD
- b. The tensile strength at 5% strain, MD
- c. The creep reduced tensile strength, MD
- d. The geotextile's pullout coefficients ( $F^*$ ,  $\alpha$ )

The Contractor's submittal package shall include, but not be limited to, actual test results for tension, creep, durability, construction damage, joint/seam strength, pullout and quality control. A person having the legal authority to bond the manufacturer shall attest to the certificate. Any tests required shall be performed at no additional cost to the Department. If in the opinion of the RCE, the required documentation is not provided for individual reduction factors (RF) or pullout coefficients ( $F^*$ ,  $\alpha$ ), default values for these design parameters shall be used in accordance with this specification.

**a. Ultimate Tensile Strength ( $T_{ult}$ ):**

The ultimate tensile strength,  $T_{ult}$ , shall be determined from wide width tensile tests (ASTM D 4595). Geotextile samples tested in accordance with ASTM D 4595 shall be with an 8-inch width specimen, or a 4-inch specimen width with correlation to an 8-inch width. Correlation methodology shall be submitted to, and is subject to acceptance by the RCE. All geotextile strength tests (ASTM D 4595 and ASTM D 6637) shall be conducted at a strain rate of 10% per minute based on actual gage length necessary to meet the testing sample dimension requirements. Laboratory test results documenting the ultimate tensile strength,  $T_{ult}$ , in the reinforcement direction shall be based on the minimum average roll values (MARV) for the product.

**b. Long-Term (Allowable) Design Tensile Strength ( $T_{al}$ ):**

The allowable tensile load per unit width of geotextile soil reinforcement,  $T_{al}$ , in accordance to the backfill type used shall be computed as follows:

$$T_{al} = \frac{T_{ult}}{RF}$$

**c. Reduction Factor (RF):**

The total reduction factor, RF, is the combined reduction factor for long-term degradation due to installation damage, creep, and durability. The total reduction factor, RF, shall be defined as follows:

$$RF = RF_{ID} \times RF_{CR} \times RF_D \geq 3.0$$

The individual reduction factors shall be documented in accordance with the site conditions, design calculations, and specifications. When sufficient documentation is not provided for individual reduction factors,  $RF_{ID}$ ,  $RF_{CR}$ , and  $RF_D$ , a reduction factor RF of 7.0 shall be used. The reinforcement manufacturer shall certify and document the individual reduction factors as follows:

**d. Installation Damage Reduction Factor ( $RF_{ID}$ ):**

The reduction factor for installation damage,  $RF_{ID}$ , shall be documented by field and laboratory test results and literature review, as described in ASTM D 5818 for the

reinforced backfill specified or for more severe soils. Samples subjected to installation damage shall be tested for tensile strength and deformation characteristics in accordance with ASTM D 4595. Recommended values for reduction factors for installation damage ( $RF_{ID}$ ) for various soils shall also be documented. The minimum installation damage reduction factor,  $RF_{ID}$ , shall be 1.1, regardless of product specific test results.

**e. Creep Reduction Factor ( $RF_{CR}$ ):**

Laboratory test results documenting creep performance over a range of load levels, for a minimum duration of 10,000 hours based on tension creep test (ASTM D 5262) shall be required. Creep test samples shall be of sufficient width to be representative of overall product creep response (fiber creep testing will not be accepted).

The creep-limiting strength,  $T_1$ , shall be based on extrapolating the 10,000 hours (or longer duration) tension creep tests to a 75-year design life, unless a 100-year design life is specified in the plans. The creep extrapolation method shall be based on methods described in FHWA NHI-10-025, *"Design and Construction of Mechanically Stabilized Earth Walls and Reinforced Soil Slopes"* - Appendix "D". Laboratory test results and extrapolation methodology shall be documented.

The reduction factor for creep,  $RF_{CR}$ , is defined as the ratio of the average lot specific ultimate tensile strength,  $T_{ULTLOT}$ , to the creep-limiting strength,  $T_1$ . The average lot specific ultimate tensile strength,  $T_{ULTLOT}$ , for the lot of material used for creep testing,  $T_{ULTLOT}$ , shall be determined from wide width tensile test, ASTM D 4595.

**f. Durability Reduction Factor ( $RF_D$ ):**

The total reduction factor for durability,  $RF_D$ , shall be defined as the combined effects of chemical and biological degradation. Laboratory test results, extrapolation techniques, and a comprehensive literature review shall document the reduction factor for durability for all material components in accordance with FHWA NHI-09-087, *"Corrosion / Degradation of Soil Reinforcements for Mechanically Stabilized Earth Walls and Reinforced Soil Slopes"*. The minimum durability reduction factor,  $RF_D$ , shall be 1.1, regardless of product specific test results.

**g. Soil Reinforcement Pullout Coefficients ( $F^*$ ,  $\alpha$ ):**

The Certification Package shall document the pullout coefficients ( $F^*$ ,  $\alpha$ ) meet or exceed the required coefficients necessary to obtain the  $T_{al}$  provided above where,

$$F^* = \text{Minimum pullout friction factor} = C_i \tan \Phi,$$

$$C_i = \text{Soil interaction coefficient} \geq 0.6$$

$$\Phi = \text{Soil Angle of Internal Friction}$$

The pullout friction factor,  $F^*$ , and the scale effect correction factor,  $\alpha$ , shall be documented by laboratory testing from pullout tests. Pullout testing shall be conducted for site-specific materials or for materials representative of the reinforced backfill at confining pressures specified by the Engineer. When laboratory tests are used from representative soils, the representative soils shall be documented by providing the soil's angle of internal friction, gradation, and coefficient of uniformity ( $C_u = D_{60}/D_{10}$ ). Recommended pullout coefficients for various soil types shall also be documented. The pullout coefficients shall be determined by using the quick effective stress pullout tests ("Measuring Geosynthetic Pullout Resistance in Soil" per ASTM D 6706). The soil interaction coefficient,  $C_i$ , shall be documented when computing the pullout friction factor,  $F^*$ . When sufficient documentation is not provided for pullout coefficients,  $F^*$  and  $\alpha$ , and the coefficient of uniformity,  $C_u$ , is greater or equal to 4, the default values indicated in this specification can be used. If the coefficient of uniformity of the reinforced backfill is less than 4,

laboratory pullout test shall be required to determine pullout friction factor,  $F^*$ , and the default scale effect factor,  $\alpha$ .

**5. Sample Approval.**

To confirm that the on-site geotextile meets the property values specified, random samples shall be submitted to the RCE for evaluation. The machine direction shall be marked clearly on each sample submitted for evaluation. The machine direction is defined as the direction perpendicular to the axis of the roll.

Cut a sample from the geotextile roll with the minimum dimensions of 4 feet by the full width of the roll beyond the first wrap. The geotextile samples shall be cut from the roll with scissors, sharp knife, or other suitable method that produces a smooth edge and does not cause geotextile ripping or tearing. Submit a manufacturer's certificate of compliance signed by an authorized manufacturer's official. The certificate must attest that the geotextile meets all the Minimum Average Roll Value (MARV) requirements specified in Table 1 as evaluated under the manufacturer's quality control program. Geotextiles supplied for construction of the project shall be certified in accordance with the following criteria. The tests described in the specification shall be conducted by the manufacturer or by an approved independent testing laboratory on samples taken from the same lot number as the material actually shipped to the project and at the specified frequency. The manufacturer or independent testing laboratory shall maintain the appropriate accreditations and must be preapproved by the Department. All rolls shall be marked with individual and distinct roll numbers. All roll numbers shall have traceable certified mill test reports from the given lot that they were manufactured. These test reports must be supplied to the Department prior to installation of any geotextile materials. After the sample and the required information have been submitted to the RCE, allow 30 calendar days for evaluation.

Product acceptance is determined by comparing the average test results of all specimens within a given sample to the Minimum Average Roll Values (MARV) listed in Table 1. Install geotextiles only after the material has been tested and/or evaluated and accepted. Replace all geotextiles installed prior to acceptance that do not meet specifications at Contractor's expense.

**a. Sewn Seam Approval**

If the geotextile seams are to be sewn in the field, the Contractor shall provide a section of sewn seam that can be sampled by the RCE before the geotextile is installed. The sewn seam shall be in accordance with ASTM 6193.

The seam sewn for sampling shall be sewn using the same equipment and procedures as will be used to sew the production seams. The seam sewn for sampling must be at least 6 feet in length. If the seams are sewn in the factory, the Contractor shall provide samples of the factory seam at random from any of the rolls to be used. Regardless of whether the seam is to be sewn in the factory or the field, the manufacturer and/or Contractor shall certify that the strength meets the requirement set forth in Table 1. If seams are to be sewn in both the machine and cross-machine direction, provide samples of seams from both directions. The seam assembly description shall be submitted by the Contractor to the Engineer and will be included with the seam sample obtained for testing. This description shall include the seam type, stitch type, sewing thread type(s), and stitch density.

If sewn seams are used for seaming the geotextile, use thread that consists of high strength polypropylene or polyester. Do not use nylon thread. Use thread that is of contrasting color to that of the geotextile itself.



## EXHIBIT 5 – SPECIAL PROVISIONS AND CONTRACT REQUIREMENTS

If the manufacturer can provide a  $T_{al}$  MD that is greater than the sum of the required  $T_{al}$  MD and sewn seam breaking strength (for each specified in the project plans), the sewn seams may be eliminated and a minimum overlap of 1 foot may be used.

### 6. Identification, Shipment and Storage

Conform to ASTM D 4873, *Standard Guide for Identification, Storage, and Handling of Geotextiles*. Clearly label each roll of geotextile shipped to the project with the name and address of the manufacturer, full product name/number, quantity, and roll number.

The RCE will reject materials that are mislabeled or misrepresented. Wrap each roll with a material that protects the geotextile, including ends of the roll, from damage due to shipment, water, sunlight, and contaminants. Maintain the protective wrapping during periods of shipment and storage. Do not damage the geotextile or wrapping when unloading or transferring from one location to another. Do not drag the rolls.

During storage, elevate geotextile rolls off the ground and adequately cover to protect them from the following:

- a. Site construction damage;
- b. Precipitation;
- c. Ultraviolet radiation including sunlight;
- d. Chemicals that are strong acids or strong bases;
- e. Flames including welding sparks, temperatures in excess of 140 °F (60 °C); and
- f. Mud, dirt, dust, debris and any other environmental condition that may damage the physical property values of the geotextile

### C. CONSTRUCTION REQUIREMENTS

#### 1. General

Prepare the surface on which the geotextile is to be placed so that no damage occurs to the geotextile. Do not drive or operate any construction equipment directly on the geotextile. Dispose of material with defects, rips, holes, flaws, deterioration, or other damage. Do not use defective material in the work. The manufacturer shall be present on site for a minimum of two days of geotextile installation such that the manufacturer observes any field-sewn seams.

#### 2. Installation Plan

Within thirty (30) calendar days after award of the contract or no later than thirty (30) calendar days before beginning high-strength geotextile installation, the Contractor shall submit to the Department for review a high-strength geotextile installation plan that includes as a minimum the following information:

- a. The Contractor shall certify and provide proof to the Department of experience in the work described. The Contractor shall have successfully installed at least 500,000 square yards of any geotextile that has sewn seams during the last five years. In addition, the Contractor shall have successfully completed at least five projects within the last five years of similar size and complexity to that of the Project.

The Contractor's experience shall be documented by providing a project summary that includes for each referenced project, the project start and completion dates, total quantity of geotextile installed (specifically indicate if high-strength geotextile installed), and a detailed description of the project, site conditions, and subsurface conditions. The project description shall include details of the geotextile materials, the equipment and technique used to install the geotextiles, the average and maximum area of geotextile installed, the client name and address, the name and telephone number of the representative of the consultant and owner for whom the work was performed and who can attest to the

successful completion of the work, and any other information relevant to demonstrating the Contractor's qualifications.

- b. Resume of supervisor documenting experience and qualifications in the installation of both normal and high-strength geotextile. The Contractor shall have a full-time supervisor who has been in responsible charge of supervising geotextile installation operations for at least five projects in the last five years. The supervisor shall be present at the work site at all times during installation operations. The acceptability of the supervisor, as well as any replacement for the supervisor, will be subject to the approval of the Department.
- c. Shop drawings showing the planned locations and elevations of all high-strength geotextiles. The installation sequence shall also be provided including any required staging. The shop drawings shall also show the location of the bridge abutment, and the limits of the final embankment and construction staging.
- d. Detailed description of proposed installation procedures
- e. Proposed methods and equipment for sewn seams

**3. Site Preparation**

Prepare the installation site by clearing, grubbing, and excavating or filling the area to the design grade. This includes removal of topsoil or vegetation. The RCE will identify soft spots and unsuitable areas during site preparation. This may include but not be limited to proof-rolling specific areas defined by the RCE. Excavate these areas and backfill with approved borrow or bridge lift material and compact as specified. The area to be covered by the geotextile shall be graded to a smooth, uniform condition free from ruts, potholes, and protruding objects such as rocks or sticks.

The Contractor may construct a working platform, up to 2 feet in thickness, in lieu of grading the existing ground surface. A working platform is required where stumps or other protruding objects which cannot be removed without excessively disturbing the subgrade are present. These areas shall be prepared in accordance with the 2007 Standard Specifications for Highway Construction. The stumps shall be covered with at least 6 inches of fill before placement of the first geotextile layer.

**4. Geotextile Placement**

The geotextile shall be spread immediately ahead of the covering operation. The geotextile shall be laid with the machine direction perpendicular or parallel to centerline as shown in Plans. All seams shall be sewn. Seams to connect the geotextile strips end to end will not be allowed. The geotextile shall not be left exposed to sunlight during installation for a total of more than 14 calendar days. The geotextile shall be laid smooth without excessive wrinkles. Under no circumstances shall the geotextile be dragged through mud or over sharp objects, which could damage the geotextile.

Small soil piles or the manufacturer's recommended method shall be used as needed to hold the geotextile in place until the specified cover material is placed. Remove wrinkles and folds by pulling the geotextile taut as required.

Should the geotextile be torn or punctured or the sewn joints disturbed, as evidenced by visible geotextile damage, subgrade pumping, intrusion, or roadbed distortion, the backfill around the damaged or displaced area shall be removed and the damaged area repaired or replaced by the Contractor at no expense to the Department. The repair shall consist of a patch of the same type of geotextile placed over the damaged area. The patch shall be sewn at all edges.

If geotextile seams are to be sewn in the field or at the factory, the seams shall consist of two parallel rows of stitching, or shall consist of a J-seam, Type SSn-2. The two rows of stitching shall be 1 inch apart with a tolerance of plus or minus 0.5 inches and shall not

cross, except for re-stitching. The stitching shall be a lock-type stitch. The minimum seam allowance, i.e., the minimum distance from the geotextile edge to the stitch line nearest to that edge, shall be 1.5 inches if a flat or prayer seam, Type SSa-2, is used. The minimum seam allowance for all other seam types shall be 1 inches. The seam, stitch type, and the equipment used to perform the stitching shall be as recommended by the manufacturer of the geotextile and as approved by the RCE.

The seams shall be sewn in such a manner that the seam can be inspected readily by the RCE or his representative. The seam strength will be tested and shall meet the requirements stated herein.

**5. Fill Placement.**

Embankment construction shall be kept symmetrical at all times to prevent localized bearing capacity failures beneath the embankment or lateral tipping or sliding of the embankment. Place fill over the geotextile by dumping onto previously placed material and pushing the material into place. Stockpiling of fill on the geotextile will not be allowed. Do not operate any construction equipment directly on the geosynthetic material under any circumstances.

Place the fill material in uniform layers so that there is a minimum lift thickness (loose) of 8 inches between the geosynthetic material and equipment tires or tracks at all times. The minimum thickness of the first lift is 8 inches. Do not allow construction equipment to turn on the first lift of material above the geosynthetic material. Do not blade the first lift placed over the geosynthetic material. If the subgrade is very soft with an undrained shear strength less than 500 psf, minimize pile heights to less than 3 feet and spread piles as soon as possible after dumping to minimize the potential for localized subgrade failure due to overloading of the subgrade.

Do not use sheepsfoot or studded compaction equipment on the first lift placed over the geosynthetic material. Stop vibrator on compaction equipment if pumping occurs. Do not operate any construction equipment that results in rutting in excess of 3 inches on the first lift. If rutting exceeds 3 inches, decrease the construction equipment size and/or weight or increase the lift thickness. Use only rubber-tired rollers for compaction if any foundation failures occur when placing subsequent lifts. Compact all lifts to the moisture and density requirements for each embankment specified in the Standard Construction Specifications. Do not blade material down to remove ruts. Fill any ruts or depressions with additional material and compact to the specified density.

A sandy material that meets the requirements of an A-2 AASHTO soil classification shall be the only borrow excavation soil allowed for placement between the lowest elevation geotextile and the bottom of the pavement section. The embankment fill soils shall be compacted in accordance with the 2007 Standard Specifications for Highway Construction. Fill shall be placed in 12-inch maximum lift thicknesses where heavy compaction equipment is to be used and 6-inch maximum uncompacted lift thicknesses where hand-operated equipment is used.

The geotextile shall be pretensioned during installation using either Method 1 or Method 2 as described herein. The method selected will depend on whether or not a mudwave forms during placement of the first one or two lifts. If a mudwave forms as fill is pushed onto the first layer of geotextile, Method 1 shall be used. Method 1 shall continue to be used until the mudwave ceases to form as fill is placed and spread. Once mudwave formation ceased, Method 2 shall be used until the uppermost geotextile layer is covered with a minimum of 1 foot of compacted fill. These special construction methods are not needed for fill construction above this level. If a mudwave does not form as fill is pushed onto the first layer of geotextile, then Method 2 shall be used initially and until the uppermost geotextile layer is covered with at least 1 foot of compacted fill.

Method 1

**EXHIBIT 5 – SPECIAL PROVISIONS AND CONTRACT REQUIREMENTS**

After the working platform, if needed, has been constructed, the first layer of geotextile shall be laid as outlined in the project plans and the joints sewn together. The geotextile shall be stretched manually to ensure that no wrinkles are present in the geotextile. The fill shall be end-dumped and spread from the edge of the geotextile. The fill shall first be placed along the outside edges of the geotextile to form access roads. These access roads will serve three purposes: to lock the edges of the geotextile to form access roads, to contain the mudwave, and to provide access as needed to place fill in the center of the embankment. These access roads shall be approximately 16 feet wide. The access roads at the edges of the geotextile shall have a minimum height of 2 feet completed. Once the access roads are approximately 50 feet in length, fill shall be kept ahead of the filling operation, and the access roads shall be kept approximately 50 feet ahead of this filling operation. Keeping the mudwave ahead of this filling operation and keeping the edges of the geotextile from moving by use of the access roads will effectively pre-tension the geotextile. The geotextile shall be laid out no more than 20 feet ahead of the end of the access roads at any time to prevent overstressing of the geotextile seams.

Method 2

After the working platform, if needed, has been constructed, the first layer of geotextile shall be laid and sewn as in Method 1. The first lift of material shall be spread from the edge of the geotextile, keeping the center of the advancing fill lift ahead of the outside edges of the lift. The geotextile shall be manually pulled taut prior to fill placement. Embankment construction shall continue in this manner for subsequent lifts until the uppermost geotextile layer is completely covered with 1 foot of compacted fill.

**D. METHOD OF MEASUREMENT**

Measurement of geotextile is on a square yard basis and will be computed based on the total area of geotextile shown in the plans, exclusive of the area of geotextiles used in any overlaps, seams, and/or joints. This shall include all costs associated with installation of the geotextile. Overlaps and any geotextile waste are an incidental item.

**E. BASIS OF PAYMENT**

Payment at the contract unit price is full compensation for all resources necessary to complete the item of work under the contract. Payment for the completed and accepted quantities is made under the following:

Item No.	Pay Item	Unit
2037110	GEOTEX REINF.	SY

**(27) SECTION 205: MONITORING DEVICES – PIEZOMETER:**

May 09, 2013

Supplemental Specification for Monitoring Devices – Piezometer is revised as follows:

Section 2 Paragraphs 2 and 3 shall be replaced with the following:

“Piezometer shall be installed from the working surface to the depths shown on the plans. These depths refer to the middle of the piezometer referenced to the original ground surface. Enough cable shall be provided to run from the pressure cell to the location of the Vibrating Wire Data Collection Center (VW-DCC) plus 10 feet for each instrument. The cable used to connect the pressure cell to the VW-DCC shall meet the requirements of the instrument manufacturer/supplier. The Contractor shall supply non-conductive conduit to encase the cable between the pressure cell and VW-DCC. The conduit shall have a minimal nominal diameter of 1 inch and meet the requirements of Schedule 80 materials. Provide enough conduit to enclose all lengths of buried cable from the pressure cells to the VW-DCC. All connects in the conduit and in the cable between the pressure cell and VW-DCC shall be water proof.

## EXHIBIT 5 – SPECIAL PROVISIONS AND CONTRACT REQUIREMENTS

During roadway construction and any delay period for settlement, the piezometers will be read and analyzed by the Engineer at the same times outlined in the Special Provision for Settlement Plates. If the piezometers indicate excessive excess pore pressures at a given location during embankment placement operations, the placing of embankment material shall be suspended.”

The following shall be added to the end of Section 2 Paragraph 4:

“Figure 1 depicts the installation of a single piezometer in a borehole; however, multiple piezometers may be placed in the same borehole. The installation of multiple piezometers is not shown for clarity.”

Section 4 Paragraph1 shall be replaced with the following:

“Unit price bid for "Monitoring Devices-Piezometer" shall include all costs associated with supplying, installing, and maintaining the monitoring devices. The Contractor will monitor the devices throughout construction of the embankment and for up to a period of one year after the final delay period for settlement when embankment construction is completed. The Contractor will be responsible for ensuring the piezometers are in working order and accessible once the embankment is complete.”

### **(28) SECTION 205: SETTLEMENT PLATES:**

May 09, 2013

#### **A. GENERAL**

##### **1. Scope**

The work under this Section consists of furnishing all supervision, labor, material, equipment, and related services necessary to furnish and install settlement plates as indicated on the Drawings and specified herein. The Contractor shall accommodate the Engineer in the monitoring of settlement plates.

The purpose of the settlement-monitoring program is to:

- a. Confirm estimates of the time rate of settlement of embankments and retaining walls during construction so that construction methods may be adjusted, if necessary, to meet the project schedule;
- b. Confirm that settlement is sufficiently completed prior to final grading and paving of roadways supported on embankments and retaining walls.

Consolidation settlement of the foundation soils is expected to occur during and for a period after construction of new embankments and retaining walls. The magnitude and rate of the settlement will depend on the variation of the stratigraphy and consolidation properties of the foundation soils. To effectively manage the post-construction settlement, settlement plates shall be used to monitor the magnitude and rate of settlement during construction.

Settlement plates shall be furnished and installed by the Contractor in the presence of the Engineer. Settlement plates shall consist of a steel plate with coupling for attaching the central rod and protective PVC casing. A benchmark shall be established on stable ground that is not subject to settlement.

##### **2. Responsibilities of Contractor:**

The Contractor shall notify the Engineer at least five (5) working days prior to the installation of settlement plates.

The Contractor shall furnish and install the settlement plates in the presence of the Engineer.

## EXHIBIT 5 – SPECIAL PROVISIONS AND CONTRACT REQUIREMENTS

The Contractor shall provide a licensed surveyor to stake out and provide as-built locations and elevations of all settlement plate locations and benchmarks.

The Contractor shall protect the settlement plates and benchmarks from damage for the duration of the Contract.

The Contractor shall provide the Engineer safe access to the settlement plates for the purpose of data collection for the duration of the Contract.

The Contractor shall be responsible for locating all settlement plates in the field and ensuring that no conflicts exist between settlement plates and existing and proposed structures, utilities or other construction proposed or present at the site.

### 3. Site Preparation

The Contractor shall ensure a firm base on which heavy equipment and/or other necessary equipment can be operated safely under its own power for installation of settlement plates.

The Contractor shall accurately locate all settlement plates in accordance with Drawings. Settlement plates may be adjusted by the Contractor, with the approval of the Engineer, to avoid utilities, foundations, and all other underground construction.

### 4. Existing Soil Conditions:

The subsurface conditions encountered at the site are presented in the Contract Plans and documents.

## B. PRODUCTS

### 1. Settlement Plate

The settlement plate shall consist of a 30-in. square, 1/2-in. thick steel plate with a coupling centered on the plate for attaching a central steel rod. In addition, the plate shall have a means for keeping the protective PVC casing centered on the steel rod.

### 2. Central Steel Rod

A central steel rod shall extend from the plate vertically to allow for measurements of the elevation of the settlement plate. The rod shall be of sufficient diameter to prevent buckling or swaying over the height of the fill. In addition, the rod will either be threaded at both ends or will be threaded rod to allow for the addition of extensions. The central steel rod will include the necessary couplers to allow for the extension. Metal pipe may be substituted for the rod, provided the pipe is manufactured from similar material as the settlement plate.

### 3. Protective PVC Casing

A schedule 40 PVC pipe shall be installed around the central steel rod to protect the rod from compaction operations. The PVC casing will have an inside diameter of no less than 3 inches. The casing may have either glued or threaded joints. The joints should form a watertight seal. A protective cap shall be placed at the top of the PVC casing to prevent soil, water and other debris from being introduced into the casing. In addition, the casing shall extend a minimum of 1 foot and no more than 5 feet above the ground surface at the base of casing during fill placement. Further, the contractor shall visibly identify the location of the PVC casing to prevent damage to the casing during the placement of fill materials.

### 4. Incidentals

Incidental hardware, fasteners, tools, and the like, as necessary to install the system in accordance with these specifications, shall be provided.

**C. SUBMITTALS**

The Contractor shall submit a plan for the settlement plates indicating where the coupling and protective casing supports are to be located and the method to be used to attach the coupling and casing supports.

Within 1 week following installation, the contractor shall submit an installation record for each settlement plate, which includes the plate designation, station, offset, and elevation of the Settlement plate. The settlement plate shall be located to an accuracy of 0.01 ft (both vertically and horizontally).

**D. EXECUTION**

1. Settlement Plate Installation

The Contractor shall furnish and install settlement plates in accordance with the Drawings and these specifications and in the presence of the Engineer. Settlement plates shall be installed prior to embankment or retaining wall construction and following installation of wick drains, stone columns, or other ground improvement, and grubbing and clearing in the immediate vicinity of each settlement plate. The Contractor, only with the approval of the Engineer, may adjust settlement plate locations. The settlement plates shall be placed on a firm, level area as indicated in the plans.

2. Allowance for Settlement Plate Monitoring

The Contractor shall accommodate the Engineer during construction to provide safe and timely access to settlement plates for the purpose of obtaining measurements, as construction progresses. The Contractor shall retain a licensed land surveyor to monitor the settlement of the plates. Evaluation of the settlement plate data will be the responsibility of the Engineer.

3. Fill Height Survey

The Contractor shall make a survey of the central rods daily while fill is being placed, and twice weekly after completion of fill placement, unless directed otherwise by the Engineer. Additionally, surveys shall be made at the addition of an extension rod. The measurements shall be obtained both before and after the addition of the extension rod. Surveys made by the Contractor shall be provided to the Engineer within one week. In addition, the Contractor shall provide all readings as the elevation of the plate to the nearest 0.01 ft. Further the Contractor will provide the temperature in degrees Fahrenheit (°F) and the time (actual) of obtaining the settlement plate elevations.

4. Protection of Settlement Plates

The Contractor shall protect settlement plates from damage and vandalism for the duration of the Contract and repair or replace damaged or inoperative settlement plates at no cost to the Department.

5. Abandonment of Settlement Plates

Once the Engineer has determined that the settlement plates have served their purpose and are no longer needed, they shall be abandoned in-place. The Contractor shall remove as much of the central steel rod as can be recovered and shall cut the PVC casing off two feet beneath the finished subgrade. The Contractor shall fill the PVC casings remaining in the ground with lean grout and shall place two feet of properly compacted fill on top of the testing location.

**E. METHOD OF MEASUREMENT**

The number of settlement plates, as provided in the plans, will be paid for at the contract unit price bid for "Monitoring Device - Settlement Plates" which shall include all equipment, including

**EXHIBIT 5 – SPECIAL PROVISIONS AND CONTRACT REQUIREMENTS**

but not limited to the settlement plates; mobilization; labor; surveys; materials; incidentals and abandonment required by these Specifications.

**F. BASIS OF PAYMENT**

The price and payment for this work shall be full compensation for furnishing the necessary Settlement Plates, including the settlement plates, surveys and incidental items based on the acceptance of the Settlement Plate installation by the Engineer.

Payments shall be made under:

<b>Item No.</b>	<b>Pay Item</b>	<b>Pay Unit</b>
2038110	MON. DEVICE – SETTLEMENT PLATE	EA



EXHIBIT 5 – SPECIAL PROVISIONS AND CONTRACT REQUIREMENTS

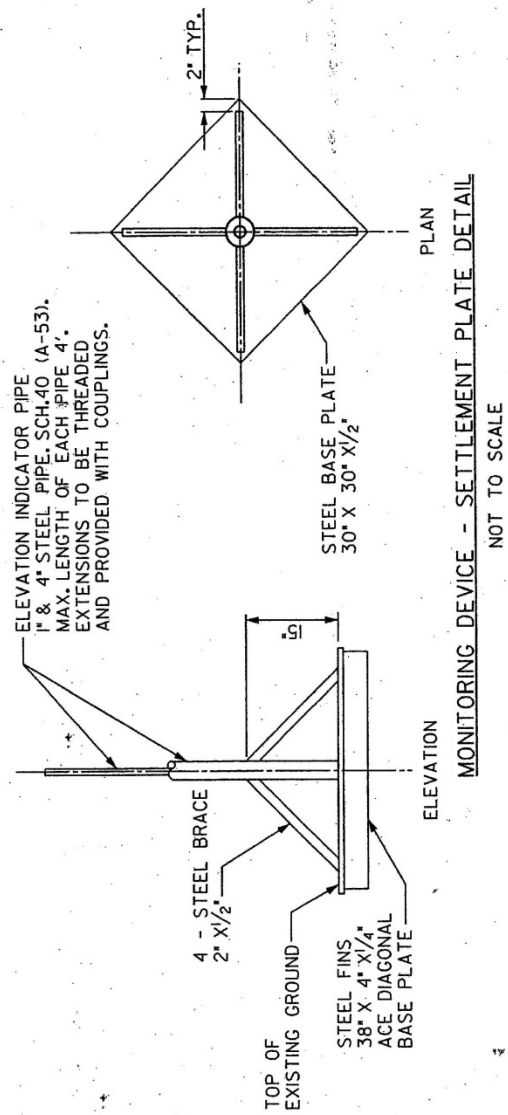

**(29) SECTION 205: SETTLEMENT SENSORS:**

August 25, 2015

**A. GENERAL**

1. Scope

The work under this Section consists of furnishing all supervision, labor, material, equipment, and related services necessary to furnish and install settlement sensors as indicated on the Drawings and specified herein. The Contractor shall accommodate the Engineer in the monitoring of settlement sensors.

The purpose of the settlement-monitoring program is to:

- a. Confirm estimates of the time rate of settlement of embankments and retaining walls during construction so that construction methods may be adjusted, if necessary, to meet the project schedule;
- b. Confirm that settlement is sufficiently completed prior to final grading and paving of roadways supported on embankments and retaining walls.

Consolidation settlement of the foundation soils is expected to occur during and for a period after construction of new embankments and retaining walls. The magnitude and rate of the settlement will depend on the variation of the stratigraphy and consolidation properties of the foundation soils. To effectively manage the post-construction settlement, settlement sensors shall be used to monitor the magnitude and rate of settlement during construction.

Settlement sensors shall be furnished and installed by the Contractor in the presence of the Engineer. Settlement sensors shall consist of a steel plate with the attached sensor equipment designed to be buried within soil fill and connected to a liquid reservoir, which is set in stable ground that is not subject to settlement. Settlement measurements are referenced to the fluid level of the reservoir supported on stable ground.

2. Responsibilities of Contractor:

The Contractor shall notify the Engineer at least five (5) working days prior to the installation of settlement sensors.

The Contractor shall furnish and install the settlement sensors in the presence of the Engineer.

The Contractor shall provide a licensed surveyor to stake out and provide as-built locations and elevations of all settlement sensors and liquid reservoir locations.

The Contractor shall protect the settlement sensors and liquid reservoirs from damage for the duration of the Contract.

The Contractor shall provide the Engineer safe access to the settlement sensors for the purpose of data collection for the duration of the Contract.

The Contractor shall be responsible for locating all settlement sensors in the field and ensuring that no conflicts exist between settlement sensors, liquid reservoir locations and existing and proposed structures, utilities or other construction proposed or present at the site.

3. Site Preparation

The Contractor shall ensure a firm base on which heavy equipment and/or other necessary equipment can be operated safely under its own power for installation of settlement sensors.

## EXHIBIT 5 – SPECIAL PROVISIONS AND CONTRACT REQUIREMENTS

The Contractor shall accurately locate all settlement sensors in accordance with Drawings. Settlement sensors shall be adjusted by the Contractor, with the approval of the Engineer, to avoid utilities, foundations, and all other underground construction.

#### 4. Existing Soil Conditions:

The subsurface conditions encountered at the site are presented in the Contract Plans and documents.

### **B. PRODUCTS**

#### 1. Settlement Sensor

The settlement sensor shall consist of a 12-in. square, ¼-in. thick steel plate with an attached vibrating wire pressure sensor. A liquid reservoir and readout panel shall also be supplied in a waterproof casing. The Contractor shall supply weather resistant locks and keys for the casings. The Contractor shall provide all keys to the Engineer. The liquid reservoir shall have a graduated scale attached so that the liquid level can be checked visually. The manufacturer's instruction and installation manual shall be supplied with the settlement sensor. The sensor shall have the signal cable and tubing attached and factory saturated with a 50% ethylene glycol antifreeze solution, ready for connection to the readout panel and liquid reservoir. The liquid reservoir shall have two tubing connections to the sensor to allow for flushing if necessary. Additional antifreeze solution shall be provided to fill the liquid reservoir and saturate the tubing connections. The vibrating wire pressure sensor shall be self-compensated for variations in barometric pressure, and have a built in temperature sensor for correction of temperature variations. The vibrating wire sensor shall be vented to the air space at the top of the liquid reservoir to accomplish the self-compensation for barometric pressure, and a moisture trap shall be included in series with the vent tubing. The settlement sensor shall have a minimum range of 5 ft, a resolution of 0.01 ft, and a system accuracy of  $\pm 0.02$  ft. All above ground components of the settlement sensor system shall be insulated.

Settlement sensor model 4650 manufactured by Geokon, Inc. of Lebanon, NH, or equivalent, shall be supplied. Catalog sheet for 4650 Settlement sensor is attached at the end of this specification for reference.

#### 2. Support Post

A metal or wooden post shall be provided for mounting the liquid reservoir and readout panel. The post shall be long enough so that it can be set a minimum of 3-ft below the stable ground surface, and the readout panel will be mounted no less than 2-ft off of the ground.

#### 3. Sand Backfill

Clean sand backfill with no particles larger than 3/8-in. shall be provided to backfill around the signal cable and tubing leading from the settlement plate to the liquid reservoir and readout panel.

#### 4. Incidentals

Incidental conduit, hardware, fasteners, tools, electronic readouts and the like, as necessary to install the system in accordance with the manufacturer's manual, shall be provided.

### **C. SUBMITTALS**

The Contractor shall submit the Specification sheet for the settlement sensor prior to purchase of settlement sensor for review and approval of the Engineer. Locations for the liquid reservoir shall also be submitted for approval, so that the proper length of signal cable and tubing can be purchased.

## EXHIBIT 5 – SPECIAL PROVISIONS AND CONTRACT REQUIREMENTS

Upon receipt of the settlement sensor, the Contractor shall submit copies of calibration sheets and the manufacturer's installation and instruction manual for review and approval of the Engineer, and shall make available the settlement sensor for inspection by the Engineer.

Within 1 week following installation, the contractor shall submit an installation record for each settlement plate which includes the plate designation, station, offset, and elevation of the Settlement sensor, and station offset and elevation of the liquid reservoir. The settlement sensor shall be located to an accuracy of 0.01 ft (both vertically and horizontally).

### D. EXECUTION

#### 1. Settlement Sensor Installation

The Contractor shall furnish and install settlement sensors in accordance with the Drawings and these specifications and in the presence of the Engineer. Settlement sensors shall be installed prior to embankment or retaining wall construction and following installation of wick drains, stone columns, or other ground improvement, and grubbing and clearing in the immediate vicinity of each settlement plate. Settlement sensor locations shall be adjusted by the Contractor only with the approval of the Engineer.

Settlement sensor installation shall be in accordance with the manufacturer's recommendations as presented in their instruction and installation manual. The liquid reservoir shall be located clear of the construction area, in an area where no fill will be placed and no settlement is anticipated. The liquid reservoir and readout panel shall not be located in drainage swales, storm water detention ponds or other areas where the panel may become submerged. A licensed surveyor shall provide a survey of the installed sensor and liquid reservoir. The survey reference point for the liquid reservoir and readout panel shall be permanently marked so that subsequent surveys may be referenced to this mark.

#### 2. Allowance for Settlement Sensor Monitoring

The contractor shall accommodate the Engineer during construction to provide safe and timely access to settlement sensors for the purpose of obtaining measurements, as construction progresses. Evaluation of the settlement sensor data will be the responsibility of the Engineer.

#### 3. Fill Height Survey and Liquid Reservoir Survey

The Contractor shall make a survey of the ground surface elevation above each settlement sensor twice weekly while fill is being placed, and once every two weeks when fill is not being placed, unless directed otherwise by the Engineer. The purpose of these measurements is to provide the Engineer with a time-history of the embankment or retaining wall height for correlation with settlement measurements. Survey of the liquid reservoir and readout panel elevation shall be made every four weeks, or if disturbance of the liquid reservoir is suspected, or as directed by the Engineer. Surveys made by the Contractor shall be provided to the Engineer within one week.

#### 4. Protection of Settlement Sensors

The Contractor shall protect settlement sensors from damage and vandalism for the duration of the Contract and repair or replace damaged or inoperative settlement sensors at no cost to the Department.

#### 5. Abandonment of Settlement Sensors

Once the Engineer has determined that the settlement sensors have served their purpose and are no longer needed, they shall be abandoned in-place. The Contractor shall remove recoverable portions of the settlement sensor, likely consisting of only the liquid reservoir and readout panel. All recoverable instrumentation shall remain property of the Contractor. The Contractor shall remove the ethylene glycol antifreeze solution from the buried tubing

## EXHIBIT 5 – SPECIAL PROVISIONS AND CONTRACT REQUIREMENTS

that is left in place by use of either a vacuum pump or by blowing out the tubing with air pressure. The antifreeze solution shall be contained and disposed of offsite in a proper manner by the Contractor.

### E. METHOD OF MEASUREMENT

The number of settlement sensors, as provided in the plans, will be paid for at the contract unit price bid for "Monitoring Device - Settlement Sensors" which shall include all equipment, including but not limited to the settlement sensor, liquid reservoir, water proof casing; mobilization; labor; surveys; materials; incidentals and abandonment required by these Specifications.

### F. BASIS OF PAYMENT

The price and payment for this work shall be full compensation for furnishing the necessary Settlement Sensor, including the settlement sensor, the liquid reservoir, the waterproof casing, surveys and incidental items based on the acceptance of the Settlement Sensor installation by the Engineer.

Payments shall be made under:

Item No.	Pay Item	Pay Unit
2038115	MON. DEVICE – SETTLEMENT SENSOR	EA

### Model 4650 Settlement System



● Model 4650 Settlement System.

#### Applications

The Model 4650 is designed for remote measurement of the settlement of a point in or below fills, surcharges, embankments, etc. Systems with tube lengths of up to 300 m have been used successfully to measure settlements in earth dam embankments.

#### Operating Principle

A vibrating wire pressure sensor is attached to a settlement plate located at the point of settlement. The sensor is connected via two liquid-filled tubes, extending laterally, to a reservoir located on stable ground. The sensor measures the hydraulic head of liquid between the sensor and reservoir locations.

#### Advantages and Limitations

A vented cable runs from the sensor to the remote readout location and connects to the reservoir so that barometric pressure fluctuations do not affect the readings.

The liquid-filled tubes can be flushed to remove any air bubbles that might form.

It is possible to perform in-situ checks at any time on both the calibration and zero stability.

#### Technical Specifications

Standard Ranges <sup>1</sup>	7, 17 m (20, 50 ft.)
Resolution/Sensitivity	2, 4 mm (0.08, 0.16 in.)
System Accuracy <sup>2</sup>	±4 to ±6 mm (±0.16 to ±0.24 in.)
Temperature Range <sup>1</sup>	-20°C to +80°C

<sup>1</sup>Other ranges available on request.  
<sup>2</sup>Sensor accuracy 0.1% F.S.

## EXHIBIT 5 – SPECIAL PROVISIONS AND CONTRACT REQUIREMENTS

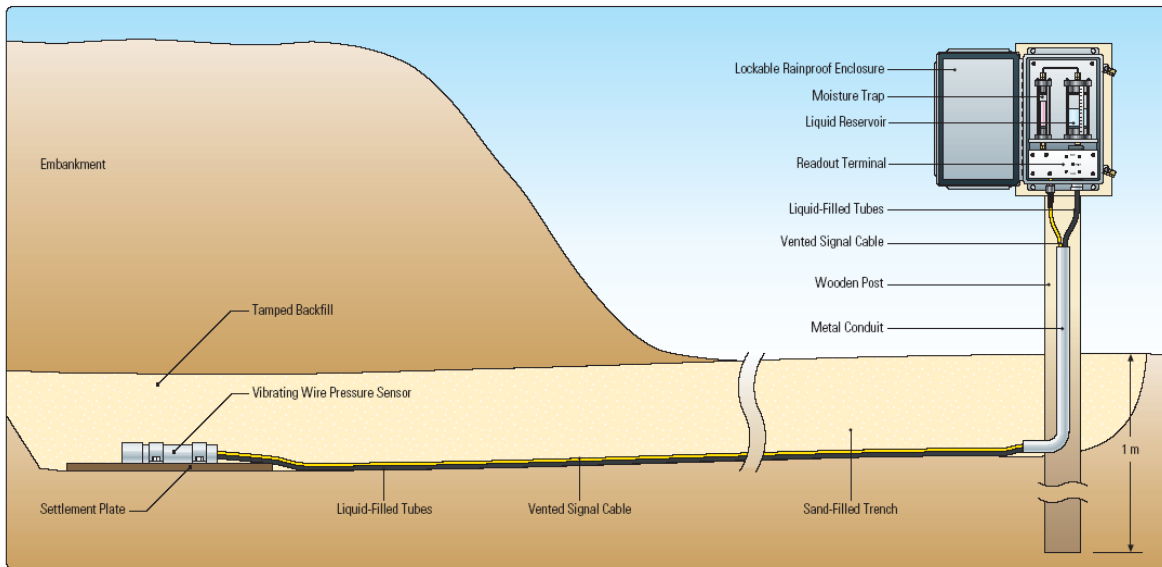

● Model 4650 installation for the remote measurement of subsurface settlement beneath a large embankment.

### (30) SECTION 205: VIBRATING WIRE ROD EXTENSOMETER:

May 24, 2013

#### A. DESCRIPTION

This work includes furnishing all supervision, materials, equipment, labor, and related services necessary for providing, installing and maintaining a Vibrating Wire Rod Extensometer (VWRE) at the locations indicated in the plans and in accordance with these specifications. This item includes the furnishing of as-built drawings of actual locations where instrumentation was installed, survey data recorded during instrumentation installation, and installation field reports. Also included in this item of work is the initial and periodic/continuous recording of VWRE readings and reporting to the Engineer in accordance with the Department's Geotechnical Instrumentation Monitoring Plan for the entire duration of the project.

The purpose of the instrumentation monitoring program is to monitor settlement of the approach embankments.

The Contractor shall be familiar with project geotechnical conditions and recognize that geotechnical data is available with geotechnical boring logs, laboratory testing results, and other pertinent information.

#### B. VIBRATING WIRE ROD EXTENSOMETER

The Vibrating Wire Rod Extensometer is an automated device for monitoring settlement. The VWRE shall contain 6 rod extensometers that will measure settlement at different depths below the ground surface. The depths of data collection are indicated in the project plans. The rod extensometers will be housed in a casing of sufficient diameter to allow for 6 rods in each casing. The VWRE shall be capable of measuring settlements of 18 inches. The VWRE shall have an accuracy  $\pm 0.1$  percent with a thermal effect of  $< 0.05$  percent for a temperature range of  $-4^{\circ}\text{F}$  to  $176^{\circ}\text{F}$ . In addition, the VWRE shall have a long-term stability of  $< 0.2$  percent per year. The location of each rod extensometer cluster is indicated in the project plans. Each rod extensometer cluster will be connected to a data collection center. The cluster shall be installed in accordance with the manufacturer's recommendations. Each VWRE cluster shall be connected to the data collection center either via cable or via cellular communications. If cable is used, enough cable shall be provided to run from the VWRE to the location of the Vibrating Wire

## EXHIBIT 5 – SPECIAL PROVISIONS AND CONTRACT REQUIREMENTS

Data Collection Center (VW-DCC) plus 10 feet for each instrument. The cable used to connect the VWRE to the VW-DCC shall meet the requirements of the instrument manufacturer/supplier. The Contractor shall supply non-conductive conduit to encase the cable between the VWRE and VW-DCC. The conduit shall have a minimal nominal diameter of 1 inch and meet the requirements of Schedule 80 materials. Provide enough conduit to enclose all lengths of buried cable from the VWRE to the VW-DCC. All connections in the conduit and in the cable between the VWRE and VW-DCC shall be water proof.

### C. SUBMITTALS

Within 30 calendar days before installing the VWRE, the Contractor shall submit to the Department for review the personnel qualification, installation plan, and monitoring plan. The submittals shall contain as a minimum the following information.

#### 1. Qualifications:

The Contractor shall identify the licensed surveyor who shall be responsible for providing survey services during the installation of the VWRE. The Contractor shall identify the geotechnical engineer that will be responsible for installing and maintaining the VWRE. The same geotechnical engineer that is responsible for the VW-DCC and piezometers will also be responsible for the VWRE. The geotechnical engineer's experience in installing VWRE in accordance with the plans and Contract Documents shall be documented by providing a project summary, of at least three projects, that includes for each project the project name, role in providing instrumentation services, type of VWRE, equipment used, duration of the project (i.e. dates), magnitude of settlements, client name and address, name and phone number of representative of the consultant and owner for whom the work was performed and can attest to the successful completion of the work, and any other information relevant to demonstrating the geotechnical engineer's qualifications. In addition, the manufacturer/supplier shall also be on-site during the initial installation of the VWRE to ascertain that all instruments have been connected correctly. The manufacturer/supplier shall also be available for questions from either the geotechnical engineer responsible for maintaining the VWRE or from the Department concerning the data being collected.

#### 2. Installation Plan:

The installation plan shall include as a minimum the following information:

- a. The Contractor shall submit the Specification sheet for the proposed VWRE system for review and approval by the Engineer.
- b. Submit locations where VWRE will be installed if different from the location shown on the plans.
- c. Proposed installation method
- d. Proposed method to protect VWRE during construction from construction equipment, vandalism, weather

#### 3. Submittal Reviews:

Approval of the personnel qualification and installation plan by the Department shall not relieve the Contractor of its responsibility to successfully install the VWREs in accordance with the plans and specifications. Approval by the Department of the VWRE installation plan shall be contingent upon satisfactory demonstration that the VWRE is meeting the objectives of the Department's Geotechnical Instrumentation Monitoring Plan. If, at any time, the Department or the Engineer considers that the VWRE does not produce satisfactory results, the Contractor shall alter the method and/or equipment as necessary to comply with the Special Provisions and Department's Instrumentation Plan. The Department will be the sole judge in determining the adequacy of the Contractor's VWRE.

### D. DELIVERY, STORAGE, AND HANDLING

## EXHIBIT 5 – SPECIAL PROVISIONS AND CONTRACT REQUIREMENTS

The Contractor shall check all materials and equipment upon delivery to ensure that the proper items are received and are not damaged. All materials shall be stored and maintained in a clean, uncontaminated condition throughout the course of the project. Upon receipt of the VWRE, the Contractor shall submit copies of the manufacturer's installation and instruction manual for review and approval by the Engineer, and shall make available the data logging system for inspection by the Engineer.

### **E. VWRE INSTALLATION**

Upon receipt of the VWRE, the Contractor shall submit copies of calibration sheets and the manufacturer's installation and instruction manual for review and approval by the Engineer, and shall make available the VWRE for inspection by the Engineer.

The Contractor shall notify the Engineer at least fourteen (14) days prior to the installation of VWRE. The VWREs shall be furnished and installed by the Contractor in accordance with the plans and this specification and in the presence of the Engineer.

The Contractor shall be responsible for locating all VWREs in the field and ensuring that no conflicts exist between VWREs and foundations, structures, utilities or other construction proposed or present at the site.

The Contractor shall provide a licensed surveyor to stake out and provide as-built locations and elevations of all VWREs locations.

VWREs shall be installed prior to construction of the embankment. VWRE installation shall be in accordance with the manufacturer's recommendations as presented in their instruction and installation manual. The VWRE will be connected to the VW-DCC in accordance with the plans, contract documents, and manufacturer's recommendations.

The Contractor shall accurately locate all VWREs in accordance with the plans. VWREs may be adjusted by the Contractor, with the approval of the Engineer, to avoid utilities, foundations, and all other underground construction.

Within 1 week following installation, the contractor shall submit an installation record for each VWRE, which includes the instrumentation identification as provided in the plans, station/alignment, offset, and elevation. The VWRE shall be located to an accuracy of 0.01 ft (both vertically and horizontally).

The Contractor shall protect VWRE locations from damage and vandalism for the duration of the Contract and repair or replace damaged or inoperative VWREs at no cost to the Department.

### **F. ABANDONMENT OF VWRE**

Once the Engineer has determined that the VWRE systems have served their purpose and are no longer needed, the VWRE systems shall be abandoned in-place. The Contractor shall remove recoverable portions of the VWRE. All recoverable instrumentation shall remain property of the Contractor. The Contractor shall remove no more than 2 feet of the conduit that extends into the embankment and shall seal the conduit left in place within the embankment using a lean grout mix.

### **G. METHOD OF MEASUREMENT**

The number of VWRE provided in the plans, will be paid for at the contract unit price bid for "Vibrating Wire Rod Extensometer" which shall include all equipment, including but not limited to the VWRE, water proof casing; mobilization; labor; surveys; materials; incidentals and abandonment required by these Specifications along with VWRE data as outlined in the Geotechnical Instrumentation and Monitoring Plan. Payment will not be made for VWRE that malfunction or are rejected for their inability to perform, or do not meet the requirements in the plans and these specifications.



**EXHIBIT 5 – SPECIAL PROVISIONS AND CONTRACT REQUIREMENTS**

**H. BASIS OF PAYMENT**

The price and payment for this work shall be full compensation for furnishing the necessary data logging system, enclosure, protection from vandalism and construction equipment, data as outlined in the Geotechnical Instrumentation and Monitoring Plan, and incidental items based on the successful implementation of the VWRE system.

Payments shall be made under:

<b>Item No.</b>	<b>Pay Item</b>	<b>Pay Unit</b>
2038140	MON. DEVICE – VIBRATING WIRE ROD EXTENSOMETERS	EA

**(31) SECTION 205: VIBRATING WIRE DATA COLLECTION CENTERS:**

May 24, 2013

**A. DESCRIPTION**

This work includes furnishing all supervision, materials, equipment, and labor, and related services necessary for providing and maintaining a Vibrating Wire Data Collection Center (VW-DCC) at the locations indicated in the plans and in accordance with these specifications. This work consists of automating the data collection for vibrating wire rod extensometers (RE), total pressure cells (TPC), and piezometers (PZ) with a real-time system that is accessible via the internet in accordance with the Department's Geotechnical Instrumentation Monitoring Plan for the entire duration of the project as determined necessary for evaluating the settlement and pressure instrumentation of the embankments being constructed.

**B. VIBRATING WIRE DATA COLLECTION CENTER**

The Vibrating Wire Data Collection Center (VW-DCC) is an automated centralized vibrating wire data collection center. The VW-DCC will be used to collect VWRE, TPC and PZ readings. Temperature readings shall also be collected when instrumentation contains thermistors. The automated collection of VW data shall be accomplished by using a data logging system that is sufficiently capable to monitor the VW sensors indicated in the plans and with the capability of adding four additional rod extensometers and six piezometers to the system. Sufficient ports shall be provided to also monitor temperature. The reserve instrumentation monitoring capacity can be either achieved by using a data logging system with sufficient ports or by having the capability to expand the system if needed. The Contractor shall maintain compatibility between the data logging system and the rod extensometers, total pressure cells, and piezometer instrumentation. In order to maintain compatibility of the systems and be able to get technical assistance from the manufacturer during installation and throughout the project, the VW-DCC system should be supplied / manufactured by the same company that is supplying the VWRE, TPC, and PZ instrumentation. In addition, the VW-DCC shall have the following features:

1. Data logging system with sufficient capacity to read and save instrumentation readings
2. The data logging system shall have the reserve capacity to add additional instrumentation if needed
3. Powered by on-site AC current
4. Battery power back-up with surge suppression
5. Telephone/cellular access for transmitting data through the internet
6. Dedicated server for storing and running viewing software
7. On-line instrumentation software for reviewing/downloading instrumentation data
8. Enclosure that protects the equipment from damage during construction, vandalism, and weather

## EXHIBIT 5 – SPECIAL PROVISIONS AND CONTRACT REQUIREMENTS

Data collected via the VW-DCC shall be provided to the Department in the format outlined in the Geotechnical Instrumentation and Monitoring Plan.

### C. SUBMITTALS

Within 30 calendar days before installing the VW-DCC, the Contractor shall submit to the Department for review the personnel qualification, installation plan, and monitoring plan. The submittals shall contain as a minimum the following information.

#### 1. Qualifications:

The Contractor shall identify the geotechnical engineer that will be responsible for installing and maintaining the VW Data Collection Center. The same geotechnical engineer that is responsible for the vibrating wire REs, TPCs, and PZs will also be responsible for the VW-DCC. The geotechnical engineer's experience in providing automated data logging capabilities such as the VW-DCC in accordance with the plans and contract documents shall be documented by providing a project summary, of at least three projects, that includes for each project the project name, role in providing instrumentation services, type of data logging system, equipment used, duration of the project (i.e. dates), client name and address, name and phone number of representative of the consultant and owner for whom the work was performed and can attest to the successful completion of the work, and any other information relevant to demonstrating the geotechnical engineer's qualifications. In addition, the manufacturer/supplier shall also be on-site during the initial installation of the VW-DCC to ascertain that all instruments have been connected correctly. The manufacturer/supplier shall also be available for questions from either the geotechnical engineer responsible for maintaining the VW-DCC or from the Department concerning the data being collected.

#### 2. Installation Plan:

- a. The installation plan shall include as a minimum the following information:
- b. The Contractor shall submit the Specification sheet for the proposed VW-DCC system for review and approval by the Engineer
- c. Submit locations where VW-DCC will be installed
- d. Proposed installation method
- e. Proposed method to protect VW-DCC during construction from construction equipment, vandalism, weather

#### 3. Submittal Reviews:

Approval of the personnel qualification and installation plan by the Department shall not relieve the Contractor of its responsibility to successfully install the VW REs, TPCs, and PZs and monitor this instrumentation with VW-DCC in accordance with the plans and specifications. Approval by the Department of the VW-DCC installation plan shall be contingent upon satisfactory demonstration that the VW-DCC is meeting the objectives of the Department's Geotechnical Instrumentation Monitoring Plan. If, at any time, the Department or the Engineer considers that the VW-DCC does not produce satisfactory results, the Contractor shall alter the method and/or equipment as necessary to comply with the Special Provisions and Department's Instrumentation Plan. The Department will be the sole judge in determining the adequacy of the Contractor's VW-DCC.

### D. DELIVERY, STORAGE, AND HANDLING

The Contractor shall check all materials and equipment upon delivery to ensure that the proper items are received and are not damaged. All materials shall be stored and maintained in a clean, uncontaminated condition throughout the course of the project. Upon receipt of the VW-DCC, the Contractor shall submit copies of the manufacturer's installation and instruction manual for review and approval by the Engineer, and shall make available the data logging system for inspection by the Engineer.

**EXHIBIT 5 – SPECIAL PROVISIONS AND CONTRACT REQUIREMENTS**

**E. ABANDONMENT OF VW-DCC**

Once the Engineer has determined that VW-DCC systems have served their purpose and are no longer needed, the VW-DCC shall be abandoned by removing all equipment and signal wires a minimum of 2 feet of ground surface.

**F. METHOD OF MEASUREMENT**

The number of VW-DCC provided in the plans, will be paid for at the contract unit price bid for "Vibrating Wire Data Collection Center" which shall include, but not limited to, all labor, materials, and equipment necessary to install a vibrating wire data collection center along with data as outlined in the Geotechnical Instrumentation and Monitoring Plan. Payment will not be made for VW-DCC that malfunction or are rejected for their inability to perform, or do not meet the requirements in the plans and these specifications.

**G. BASIS OF PAYMENT**

The price and payment for this work shall be full compensation for furnishing the necessary data logging system, enclosure, protection from vandalism and construction equipment, data as outlined in the Geotechnical Instrumentation and Monitoring Plan, and incidental items based on the successful implementation of the VW-DCC system.

Payments shall be made under:

Item No.	Pay Item	Pay Unit
8990440	VW DATA COLLECTION CENTER	EA

**(32) SECTION 205: VIBRO COMPACTION:**

June 27, 2013

**A. DESCRIPTION**

This section presents administrative and procedural requirements for ground modification by Vibro-Compaction (VC). Vibro-compaction shall be implemented in and below the existing embankment fill material of both the beginning of bridge approach embankment and the end of bridge approach embankment. VC shall be provided as documented in the plans. The purpose of the vibro-compaction program is to densify the granular soils at the specified locations and depths to mitigate liquefaction potential.

The Contractor shall perform layouts and measurements for VC work. VC points may be surveyed in or located by measuring offsets from surveyed points (e.g., project stations) using a tape measure.

The Contractor shall notify the Engineer a minimum of 48 hours prior to commencement of the VC operations at each approach embankment location.

Any change in the predetermined VC program necessitated by a change in the field conditions shall be immediately reported and submitted to the Geotechnical Engineer. Upon completion of the work, the Contractor shall submit a drawing of as-built locations of vibro-compacted columns.

**B. REFERENCES**

The Geotechnical Engineer will coordinate all testing to determine compliance with the project design.

1. Applicable Standards: The most recent version of the following testing methods or standards shall be employed:
  - a. ASTM D1586 "Standard Test Method for Standard Penetration Test (SPT) and Split-Barrel Sampling of Soils"
  - b. ASTM D5778 "Standard Test Method for Electronic Friction Cone and Piezocone Penetration Testing of Soils" (CPT)

## EXHIBIT 5 – SPECIAL PROVISIONS AND CONTRACT REQUIREMENTS

- c. ASTM D6635 “Standard Test Method for Performing the Flat Plate Dilatometer” (DMT)
2. Reference Documents: Reference documents to be used by the Contractor shall include:
    - a. This specification
    - b. Attached plans
    - c. Project geotechnical report prepared by the Geotechnical Engineer.

Prior to commencing work, the contractor shall examine the site, drawings, records of existing utilities and other existing subsurface structures, and soil test boring logs made available in the original bid documents and those performed by the Geotechnical Engineer to help determine VC installation conditions.

### C. SUBMITTALS

This section details all submittals required prior to field work, at completion of the test section, during production work, and after the work is completed.

1. Pre-Field Work Submittals: The following shall be submitted to the SCDOT by the Geotechnical Engineer prior to the start of the work. VC operations may not commence until approval by the SCDOT is granted.
  - a. A Work Plan prepared by the Contractor for the production work outlining the anticipated spacing, location and depth to achieve the project design criteria.
  - b. Drawing(s) for review, indicating the spacing, location, and depth of the VC probes to achieve the project design criteria.
2. Post Test Section and Pre Production Work:
  - a. Results of the test section evaluation.
  - b. A revised work plan and VC layout should the test section results require a modification to the original work and production plans.
3. During Production Submittals: The following shall be submitted to the SCDOT by the Geotechnical Engineer during the work:
  - a. Any change in the predetermined VC program necessitated by a change in the field conditions.
4. Closeout Submittal: The following shall be submitted to the SCDOT by the Geotechnical Engineer within 14 days of the completion of the VC work.
  - a. As built drawings: Drawings documenting any significant changes to the shop drawing. If no changes are noted, then no as-built drawings are necessary following completion of the VC program.

### D. EQUIPMENT AND MATERIALS

The Contractor shall supply equipment in good operating condition capable of performing the work specified herein. The Contractor shall use equipment capable of efficiently accomplishing the required soil densification. The probe shall have durable markings on one foot intervals allowing a visual determination of the depth of penetration when in use. The probe shall be of sufficient length to extend a minimum depth of thirty (30) feet below existing grade.

The VC procedure is not intended to be a ‘wet’ operation. Water shall be used sparingly to mitigate clogging of the VC equipment.

Settlement resulting from the VC operations is anticipated. Any required fill placement in the resulting deformations required to meet the design grade(s) shall meet the requirements outlined in the *Special Provision 40 – Section 203: Borrow Excavation* provided in the bid documents.

Groundwater is anticipated to emerge to the ground surface during VC operations. The Contractor shall implement Best Management Practices (BMP's) to efficiently control surface groundwater runoff in accordance with the contract documents.

**E. CONSTRUCTION**

Production VC criteria shall be as follows:

1. Depth of treatment: The probe tip shall penetrate to the minimum elevation specified in the above referenced documents and submittals.
2. Locations/Spacing: The center to center probe spacing shall adhere to the requirements in the above referenced documents and submittals. Probes shall be performed within 12 inches of the planned location
3. Limits of work: The limits of the VC work are shown on the drawings described in the above referenced documents and submittals.

**F. QUALITY CONTROL**

The details of the quality control program are as follows:

1. Technical Oversight: All VC operations shall be performed under the inspection of the Geotechnical Engineer's representative.
2. Monitoring and Logging: Monitoring and logging of all VC operations for the test area and production work shall be done by the Contractor.
3. Test Section: The Geotechnical Engineer's representative shall monitor the performance of the test section and perform the testing indicated below:
  - a. A test section shall be performed before production work, as follows:
    - 1) The test section location shall be agreed upon by the Geotechnical Engineer and the Contractor within the treatment area. The test section will consist of a minimum of twelve (12) VC points in three (3) rows of four (4) points each. For preliminary design considerations, the vibro-densification program will utilize a five (5) foot triangular grid for the indicated treatment area(s).
    - 2) The method of installation, materials, equipment, and procedures shall be the same as those to be used for production work.
    - 3) Based on the results from the test section, modifications to the Work Plan may be implemented, as needed, to meet the project design. Any changes to the Work Plan will be submitted to the SCDOT following completion of the test program.
  - b. The Geotechnical Engineer shall coordinate the following tests of the test section after a minimum wait period of four (4) days from completion of the VC activities of the test program: One (1) CPT (*or* SPT) test performed at the center of a VC probe location, and one (1) CPT (*or* SPT) test performed at the midpoint of adjacent VC probe locations.
  - c. The primary method for determining the post-treatment soil strength parameters for production VC work will be from the phi angle correlations in Chapter 7 of the SCDOT Geotechnical Design Manual. These equations are based on either the blow counts as determined from the SPT test, the cone tip resistance as determined from the CPT test, or the horizontal stress index as determined from the DMT test.
  - d. The production VC criteria will be based on a minimum applied relative energy for a given time rate. Following completion of the test program, the Geotechnical Engineer will establish criteria for the production VC work.

## EXHIBIT 5 – SPECIAL PROVISIONS AND CONTRACT REQUIREMENTS

4. Daily Records: Monitoring and logging of VC operations for the test area and production work shall be performed by the Contractor. At a minimum, the following information shall be collected for each VC probe location:
  - a. Equipment details and specifications
  - b. Embankment location
  - c. Probe ID (i.e. A-27)
  - d. Start and finish time
  - e. Maximum recorded energy reading
  - f. Depth of treatment
  - g. Comments or unusual observations

A sample monitoring log for the VC work is provided with this specification.

5. Monitoring of Existing Structures: There are no structures within 500 feet of the planned VC work, and, therefore, a vibration monitoring program is not required for the VC work
6. The Contractor shall ensure that procedures and documentation conform to these specifications.

### **G. METHOD OF MEASUREMENT**

The acceptance of the VC work shall be solely based on the results from the pre-treatment test program outlined in this specification. The Geotechnical Engineer shall provide to the SCDOT a signed and sealed statement that the soil improvement conforms to requirements of the project design.

### **H. RESTRICTIONS**

The Contractor shall be responsible for obtaining the necessary State and municipal permits for the intended construction. The Contractor shall be responsible for the precise delineation of all above and below ground utilities and obstructions and shall accurately mark their layout at the site. The following shall also be listed within this section when applicable:

1. Environmental restrictions
2. Work boundaries
3. Hours and days available for construction

### **(33) SECTION 205: DEEP SOIL MIXING (DSM):**

September 22, 2011

#### **A. DESCRIPTION**

This work shall consist of using deep soil mixing (DSM) construction techniques (also known as deep mixing methods, DMM) to improve weak subsurface soils by mixing a binder material with in-situ soil to produce a DSM column composed of a soil-binder mixture that has increased compressive strength and stiffness properties compared to the original in-situ soil properties. A column is defined as the extent that the existing ground is improved by insertion and removal of the mixing tool to the full improvement depth required in the plans. DSM column mixing methods allowed are described in subsection A.1 and DSM column spacing requirements are described in subsection A.2. The purpose for constructing DSM columns is to improve weak subsurface soils in order to stabilize and/or improve performance of existing ground prior to constructing bridge foundations, embankments, mechanically stabilized earth (MSE) walls, retaining walls, and other transportation structures or facilities as specified herein and shown on the plans and contract documents. References listed in subsection A.3 may be used in these special provisions and will be used to evaluate this work.

The work covered by this specification includes furnishing all necessary plant, labor, equipment, geotechnical subsurface investigation, pre-production laboratory testing, test section(s), surcharges/berms constructed at the DSM improved locations (if shown in the plans or required to meet DSM column performance requirements), in-situ testing, sampling/coring, QA/QC testing, reporting, and other work described below. The Contractor shall be familiar with project geotechnical conditions and recognize that geotechnical data is available with geotechnical boring logs, laboratory testing results, and other pertinent information.

**1. DSM Mixing Methods:**

This special provision contains specifications for construction of DSM columns by either the wet or dry mechanical mixing method. The Contractor shall use the DSM mechanical mixing method specified in the plans unless other methods are approved in writing by the Engineer. DSM column mixing method for the wet and dry mixing methods are defined as follows:

- a. **Wet Method:** The wet method consist of mixing a binder in slurry form (i.e. cement grout) with existing soils using auger-type equipment (paddles, augers, and other rigid mixing tools), without use of externally directed high pressure jets, to form a DSM column consisting of a homogeneous mixture of cement grout and in-situ soils. The wet mixing method typically produces spoils in the range of 10 to 60 percent of the treated volume. A soil-cement column formed by the wet mixing method is abbreviated herein as DSM-SCC).
- b. **Dry Method:** The dry method consists of mixing dry binders (i.e. lime-cement or cement) into the in-situ soils. The dry binder is injected into the soil by using air pressure. The mixing tool blends the binder material with the in-situ soil and water to form a DSM column of a homogeneous mixture of binder materials and in-situ soils. The dry mixing method typically produces spoils less than 10 percent of the treated volume. A DSM column (lime-cement or cement) formed by the dry mixing method is abbreviated herein as DSM-LCC.

**2. DSM Column Spacing:**

The DSM columns shall be spaced and arranged as indicated on the plans or as otherwise directed by the Engineer. DSM columns can be constructed by using group column spacing or by using block column spacing as described below:

- a. **Group Column Spacing (GCS):** DSM group column spacing (GCS) consists of constructing a single column (no overlap with adjacent DSM columns) with a diameter of 20 to 36 inches or as required in the plans. The DSM columns group spacing is defined in the plans by specifying a pattern (i.e. triangular, grid, etc.) and center-to-center spacing between DSM columns.
- b. **Block Column Spacing (BCS):** DSM block columns spacing (BCS) consists of constructing an improved soil zone with DSM columns overlapping adjacent DSM columns. Since the improved soil zone is continuous, the size of the DSM column is not specified in the plans to accommodate variations in the Contractor's equipment dimensions. As a result of Contractor equipment variations in size, any variations in the dimensions of the zone of ground improvement shown in the plans will require written approval by the Engineer. The center-to-center spacing shall be determined by the Contractor based on the DSM construction equipment in order to provide continuous overlapped DSM columns in accordance with the plans and specifications. Continuous column spacing may be achieved by the use of DSM equipment capable of constructing multiple columns simultaneously. The DSM column overlap distance between adjacent DSM columns shall be a minimum of 20 percent of the DSM column diameter or as approved by the Engineer. The DSM column center-to-center spacing between adjacent columns shall be defined as the DSM column diameter minus the column overlap distance.

**3. References:**

## EXHIBIT 5 – SPECIAL PROVISIONS AND CONTRACT REQUIREMENTS

The evaluation of this work, including the DSM Installation Plan, test section(s), QC testing, and QA testing will be based on, but not limited to, the following references:

- a. Bruce, D.A. (2000). "An Introduction to the Deep Soil Mixing Methods as Used in Geotechnical Applications, Volume I," FHWA-RD-99-138.
- b. Bruce, D.A. (2000). "An Introduction to the Deep Soil Mixing Methods as Used in Geotechnical Applications, Volume II: Appendices," FHWA-RD-99-149.
- c. Bruce, D.A. (2001). "An Introduction to the Deep Mixing Methods as Used in Geotechnical Applications, Volume III: The Verification and Properties of treated Ground," FHWA-RD-99-167.
- d. Elias, V., Welsh, J., Warren, J., Lukas, R., Collin, J.G., and Berg, R.R., (2006). "Ground Improvement Methods," Volumes I and II, FHWA NHI-06-019 and FHWA NHI-06-020, US Dept. of Transportation, Federal Highway Administration.
- e. Filz, G. M., Hodges, D. E., Weatherby, D. E., and Marr, W. A. (2005). "Standardized Definitions and Laboratory Procedures for Soil-Cement Specimens Applicable to the Wet Method of Deep Mixing." *Innovations in Grouting and Soil Improvement*, Reston, Virginia, 13.
- f. Filz, G. M. and Stewart, M. E. (2005). "Design of Bridging Layers in Geosynthetic-Reinforced, Column-Supported Embankments." Virginia Transportation Research Council, Charlottesville, VA
- g. Jacobson, J. R., Filz, G. M., and Mitchell, J. K. (2003). "Factors Affecting Strength Gain in Lime-Cement Columns and Development of a Laboratory Testing Procedure," Report prepared for the Virginia Transportation Research Council, Virginia Polytechnic Institute and State University, Report No. 57565, FHWA/VTRC 03-CR16.
- h. Jacobson, J. R., Filz, G. M., and Mitchell, J. K. (2005). "Factors Affecting Strength of Lime-Cement Columns Based on a Laboratory Study of Three Organic Soils." Deep Mixing'05: International conference on deep mixing best practice and recent advances.
- i. Larsson, S. (2005a). "State of Practice Report – Execution, monitoring and quality control," Volume 2, Deep Mixing '05: International Conference on Deep Mixing Best Practice and Recent Advances.
- j. Larsson, S. (2005b). "On the use of CPT for quality assessment of lime-cement columns." Deep Mixing '05: International Conference on Deep Mixing Best Practice and Recent Advances.
- k. McGinn, A. J. and O'Rourke, T. D. (2003). "Performance of deep mixing methods at Fort Point Channel." Cornell University.

### B. MATERIALS

#### 1. Wet Method (DSM-SCC):

*Cement:* Portland cement shall be low alkali Type II conforming to Section 701.2.1 and ASTM C150. Slag cement shall conform to Section 701.2.3 and ASTM C 989. All cement shall be homogeneous in composition and properties, and shall be manufactured using the same methods at one plant by one supplier. Tricalcium aluminate content shall not exceed 7 percent.

*Water:* Water shall conform to the requirements of Section 701.2.11.

*Admixtures:* Cement admixtures will not be allowed without written approval by the Engineer. Cement admixtures are ingredients that are used to permit efficient use of materials and proper workability of the binder material being mixed into the in-situ soils. The Contractor is required to submit any proposed admixtures and their intended effect when the binder mix design is submitted for approval by the Engineer.



## EXHIBIT 5 – SPECIAL PROVISIONS AND CONTRACT REQUIREMENTS

*Cement Grout:* The cement grout shall be a stable homogeneous mixture of cement, admixtures (if approved), and water in proportions determined by the results of the test section and approved by the Engineer. The cement grout is mixed with the in-situ soils to form DSM-SCC columns.

*Soil-Cement Mixture:* The DSM column shall be composed of a stable and uniform soil-cement mixture of cement grout and in-situ soil that meets the project compressive strength and other requirements in the plans and these special provisions. The proposed ratios of concrete grout to in-situ soils and quantities of various components shall be determined by the results of the test section and approved by the Engineer.

### 2. **Dry Method (DSM-LCC):**

*Cement:* Portland cement shall be low alkali Type II conforming to Section 701.2.1 and ASTM C150. Slag cement shall conform to Section 701.2.3 and ASTM C 989. All cement shall be homogeneous in composition and properties, and shall be manufactured using the same methods at one plant by one supplier. Tricalcium aluminate content shall not exceed 7 percent.

*Quick Lime:* Quick lime shall have at least 99 percent passing the #8 sieve (3.18 mm) and at least 90 percent passing a No. 12 Sieve (2.12 mm), an active CaO content greater than 80% and a floatability of 70.

*Premixed Lime-Cement:* If a premixed quick lime and cement is to be used, the manufacturer of the mixture must certify that the proportions of lime and cement provided are in accordance with the design requirements developed from the test section and approved by the Engineer.

*Admixtures:* Cement admixtures will not be allowed without written approval by the Engineer. Cement admixtures are ingredients that are used to permit efficient use of materials and proper workability of the binder material being mixed into the in-situ soils. The Contractor is required to submit any proposed admixtures and their intended effect when the binder mix design is submitted for approval by the Engineer.

*Binder:* The binder will be a stable homogeneous mixture of cement, lime (if applicable), and admixtures (if approved), in proportions determined by the results of the test section and approved by the Engineer. The binder material is delivered using air pressure and is mixed with the in-situ soils to form DSM-LCC columns.

*Soil-Binder Mixture:* The DSM column will be composed of a stable and uniform soil-binder mixture that meets the project design requirements and these special provisions. The proposed ratios of binder material to in-situ soils and quantities of various components shall be determined by the results of the test section and approved by the Engineer.

### C. **SUBMITTALS**

A minimum of 45 calendar days prior to beginning the DSM work, the Contractor shall submit a DSM Construction Plan and Shop Plans/Working Drawings for review and approval by the Engineer. The DSM Construction Plan and Shop Plans/Working Drawings shall be prepared, signed, and sealed by an agent/representative of the DSM Contractor that is a professional engineer licensed in the State of South Carolina. The Contractor shall not commence DSM installation without the approval of all submittals by the Engineer. Approval by the Engineer will not relieve the Contractor of its responsibilities to provide materials and equipment necessary to install DSM columns in accordance with the plans and specifications. If, at any time, the Engineer considers that the Contractor's installation operation does not produce a satisfactory DSM column, the Contractor shall alter its method and/or equipment as necessary to comply with the plans and specifications at no additional cost to the Department.

## EXHIBIT 5 – SPECIAL PROVISIONS AND CONTRACT REQUIREMENTS

The Contractor shall submit 8 sets of the DSM Construction Plan and 8 sets of Shop Plans/Working Drawings to the Preconstruction Support Engineer (PSE) for review in accordance with the requirements provided herein. Send DSM Construction Plan and Shop Plans/Working Drawings for projects designed for the Department by a design consultant directly to the consultant. For DSM Construction Plan and Shop Plans/Working Drawings sent to the PSE, send a copy of the transmittal letter to the BCE, the OMR, and the RCE. For Shop Plans sent directly to a design consultant, send a copy of the transmittal letter to the PSE, the BCE, the OMR, and the RCE. Obtain the necessary mailing information at the Preconstruction Conference.

### 1. **DSM Construction Plan:**

The DSM Construction Plan shall document and provide, as a minimum, the following information:

- a. *Qualifications:* Evidence of six years of accumulated experience over a period of 10 years and competence to construct the required DSM columns by the mixing method (i.e. wet or dry) required for the project shall be submitted. As a minimum, the Contractor shall submit a detailed description of three DSM projects completed using the required mixing method within the previous six years that demonstrate the Contractor's experience and competence. Jet grouting or penetration grouting projects will not be acceptable as representative of DSM construction techniques. Each DSM project submitted as proof of experience and competence shall have a minimum total treatment volume of not less than 20 percent of the DSM treatment volume for this project or 30,000 cubic yards of DSM treatment volume, whichever is greater, in high plasticity clay, sand, and silt. At least two of the submitted DSM projects using the required mixing method shall have average treatment depths greater than 60 feet. Each DSM project submitted shall have the following information:
  - 1) Project name, location, and completion date
  - 2) Current contact information (address, phone number, and email) of project owner, designer, geotechnical consultant, and contract manager
  - 3) Surface and subsurface conditions, and strength (average, ranges, and means used to determine strength) of DSM columns installed
  - 4) Minimum, maximum, and average rates of DSM installation
  - 5) Project cost and duration of DSM installation
  - 6) Average depths and ranges of depths of DSM columns installed. Provide total linear footage and volume (cubic yards) of DSM columns installed
  - 7) Percent of project total based on QA/QC testing that met the project Acceptance Criteria and percent of project total based on QA/QC testing that required remediation techniques after initial DSM installation

The Contractor shall also submit a list of completed ground improvement projects where they performed DSM column construction techniques over the past six years that includes items "a" and "e" listed above, type of DSM mixing, and DSM quantity constructed (similar to item "f" above).

The Contractor's proposed DSM superintendent shall have a minimum of three years of accumulated experience with DSM construction equipment and construction management within the past six years. The DSM superintendent shall have been employed by the Contractor for the most recent three years. The proposed DSM superintendent shall have been superintendent for the Contractor on at least one of the three DSM projects submitted by the Contractor as evidence of their experience. Experience and training records shall be submitted for proposed DSM superintendent and operators of construction equipment. Any changes in DSM construction personnel shall require submittal of qualifications for approval.

The Independent Testing Laboratory shall have at least 5-years' experience as a materials testing laboratory, including the performance of testing comparable to that

## EXHIBIT 5 – SPECIAL PROVISIONS AND CONTRACT REQUIREMENTS

required herein. The person in charge of the testing work for the Independent Testing Firm shall be a Professional Civil Engineer, registered in the State of South Carolina. The Independent Testing Laboratory's supervisor and each field representative who will take samples in the field shall have at least 5-years' experience in taking concrete samples in the field and performing compressive strength tests in accordance with AASHTO requirements, and be accredited as required by SCDOT to obtain and form concrete test cylinders. The persons who will perform laboratory testing shall have at least 2-years' experience in performing the soil tests required herein.

- b. *Protection of Utilities:* Location of all subsurface utilities in the area and the plan to protect them in place if the utilities are not being relocated out of the affected area.
- c. *Construction Schedule:* A construction schedule for the DSM work identifying start dates and durations for all portions of the work, including equipment mobilization, equipment setup, test section(s) construction, production DSM construction at each location, and QC testing.
- d. *DSM Mixing Method:* Provide the type of mixing method (Wet or Dry) that will be used in accordance with the plan documents to construct the DSM columns in accordance with the plans and these specifications.
- e. *Equipment and Procedures:* A detailed description of the equipment (include catalog cut sheets of equipment dimensions) and procedures to be used during all facets of the project including, but not limited to the conduct of the following:
  - 1) Test section(s)
  - 2) Site preparation
  - 3) Stage construction of DSM test section(s) and production DSM (if required)
  - 4) Locating the DSM columns in the field
  - 5) DSM spoil containment, handling, and disposal
  - 6) Confirming method to check that the DSM are installed plumb
  - 7) Quality control program
  - 8) Monitoring quality control parameters
  - 9) Sample collecting for laboratory confirmation testing
- f. *DSM Test Section Subsurface Information and Location:* Submit the probe testing results used to pre-approve the location of the test section(s). Provide a minimum of two probe test at each test section in accordance with Section H.2 for review and approval by the Engineer of the proposed location of the test section(s). Pre-approval of the test section location(s) shall be required before commencing Pre-production field and laboratory testing (Section D). Probe testing shall be conducted to the production DSM depths plus 10 feet that the test section represents. Indicate on a plan drawing the location of the test section(s), dimensions and layout of the test section(s), number of DSM columns (include designation of each DSM column), and location of probe testing performed (Section H.2). This information should be included in this submittal even if submitted previously during pre-approval of DSM test section location(s).
- g. *Pre-Production DSM Binder Mix Design Report:* Final report of pre-production laboratory and field testing used to develop proposed wet or dry binder mix design for the construction of the test section(s). The pre-production laboratory and field testing shall conform to Section D of this special provision.
- h. *Cement and Cement Grout Mix Design (Wet Mixing Method, DSM-SCC):* Proposed cement and cement grout mix design when DSM columns are constructed using the wet mixing method (DSM-SCC). The design shall include the following:
  - 1) Cement type and Cement manufacturer's certificate of compliance.
  - 2) Cement grout water-cement ratio, by weight. Include details to fully describe and illustrate the methods for grout proportioning to achieve the design mix.

## EXHIBIT 5 – SPECIAL PROVISIONS AND CONTRACT REQUIREMENTS

- 3) Cement Factor (also known as Residual Cement Factor) which is the amount of cement, dry weight in pounds, that remains in the ground after mixing, per cubic yard of in-situ soil-cement.

These mix design parameters will be reviewed based on the pre-production field and laboratory testing results developed in accordance with Section D. The acceptance of the proposed grout mix/soil/cement mix design shall be contingent on the test section(s) results meeting the acceptance criteria of Section K. The Contractor may propose to expand the size of the test section to demonstrate that somewhat different grout water/cement ratio and/or cement factor is workable in achieving the required soil-cement strength under actual in-situ conditions. Provide documentation of calibration of the mixing plant.

- i. *Binder Mix Design (Dry Mixing Method, DSM-LCC)*: Proposed binder mix design(s) when DSM columns are constructed using the dry mixing method (DSM-LCC). Binder mix design shall include all materials, quantities, and dosages required to achieve the Acceptance Criteria (Section K). The design shall include the following:

- 1) Cement type and Cement manufacturer's certificate of compliance
- 2) Quick lime (if used) manufacturer's certificate of compliance
- 3) Pre-mixed lime-cement (if used) manufacturer's certificate of compliance
- 4) Binder mix dosage of each material in the binder mix per volume
- 5) Proportion of binder material to soil in the soil-binder mixture

These mix design parameters will be reviewed based on the pre-production field and laboratory testing results developed in accordance with section D. The acceptance of the proposed binder and soil/binder mix design shall be contingent on the test section(s) results meeting the acceptance criteria of section K. The Contractor may propose to expand the size of the test section to demonstrate that somewhat different binder mix design is workable in achieving the required soil-binder strength under actual in-situ conditions. Provide documentation of calibration of the mixing plant.

- j. *Independent Laboratory Testing*: Identification of all independent AASHTO certified materials laboratory testing facilities that will be used on the project and the type laboratory testing that will be conducted at each laboratory. All laboratory testing shall be performed at a materials laboratory with current AASHTO certification for the type of test being conducted. A single independent AASHTO certified materials testing laboratory shall be used to conduct all of the compressive strength testing that will be performed on the project.
- k. *Calibrations*: Calibration tests for all metering equipment, including mixing systems, delivery systems, alignment systems, mixing tool rotational and vertical speed, injection pressure, rotation penetration/extraction rates, etc. that are applicable to the mixing method being used on the project.
- l. *Surcharges/Berms*: Details of any surcharges/berms being constructed as indicated in the plans or required to obtain DSM column performance in accordance with plans and specifications. Provide a description of materials used (soil type, Atterberg limits, moisture content, etc.), location, and removal schedule (if required). Surcharges that are required to obtain DSM column performance and are not shown in the plans shall be constructed after being approved by the Engineer and at no additional cost to the Department.
- m. *Runoff and Spoil Containment (Wet Mixing Method Only)*: Details of all run-off and spoil containment structures will be required when DSM columns are constructed using the wet mixing method (DSM-SCC). These structures will be used to prevent the migration of either cement grout or soil-cement return spoils, disturbed in-situ soils, or other soil material beyond the immediate limits of the soil-cement mixing operation. Also provide description of processes and procedures to be used to collect and retain the soil-cement return and other spoil materials in such manner to allow the spoils to solidify for the

## EXHIBIT 5 – SPECIAL PROVISIONS AND CONTRACT REQUIREMENTS

necessary time to become a hardened material resembling a hard, dry cohesive material. The resulting hardened spoils shall be disposed of off-site, at no additional cost to the Department.

n. *Daily Production Control Report and Installation Log*: Provide a sample report and installation log in paper and electronic format that will be used to record the construction of all production DSM columns for the required mixing method. The Daily Production Control Report/Log shall contain at least the following information:

- 1) Project Name
- 2) DSM column number and reference drawing number
- 3) Date
- 4) Name of DSM Superintendent and equipment operator
- 5) Start/Finish time of DSM column installation
- 6) Machine/Rig Number
- 7) Type of mixing tool and indicate if single or multiple columns formed per stroke
- 8) DSM column(s) diameter/size
- 9) DSM column(s) total length (include top and bottom elevations)
- 10) DSM column center-to-center spacing from adjacent DSM column
- 11) Verticality of mixing tool in two orthogonal planes for each DSM column
- 12) Binder mix design designation used
- 13) A description of obstructions, interruptions, DSM column construction out of tolerance or other difficulties encountered during installation of DSM column and how they were resolved
- 14) *Material Certifications*: Supplier's certifications of binder materials quality and other additives, if used

Wet Mixing Method (DSM-SCC) reports shall include the following:

- 1) Final current draw for the drilling equipment at the bottom 2 feet of penetration or final hydraulic pressure, if hydraulic motors are used to turn the mixing tools
- 2) Grout injection pressure and volume
- 3) Estimate of spoil volume
- 4) Target and actual cement factors and grout specific gravity measurements per DSM-SCC column
- 5) Date, time, plan location, and elevation and other details of all soil-cement wet grab samples and any other samples taken during work shift
- 6) The following information shall be logged using automated computer technology for each DSM-SCC installed at intervals no greater than 4 feet and presented in table and graphical forms:
  - a) Elevation in feet
  - b) Mixing tool rotation penetration and withdrawal speed in revolutions per minute vs. depth in feet
  - c) Mixing tool rotation penetration and withdrawal rates in feet per minute vs. depth in feet
  - d) Mixing tool withdrawal rate in mm/revolution vs. depth in feet
  - e) Grout injection rate in gallons per minute vs. depth in feet
  - f) Average quantity of grout injected in gallons per foot injected per vertical foot of DSM-SCC vs. depth in feet

Dry Mixing Method (DSM-LCC) reports shall include the following:

- 1) Installation air pressure at tip and top of the lime-cement column
- 2) Target and actual binder dosage mixed per DSM-LCC column
- 3) The following information shall be logged using automated computer technology for each DSM-LCC installed at intervals no greater than 4 feet and presented in table and graphical forms:
  - a) Elevation in feet

- b) Mixing tool rotation penetration and withdrawal speed in revolutions per minute vs. depth in feet
- c) Mixing tool rotation penetration and withdrawal rates in feet per minute vs. depth in feet
- d) Mixing tool withdrawal rate in mm/revolution vs. depth in feet
- e) Quantity of binder reagent (i.e. quick lime, cement, and admixtures) injected in kg/ft
- f) Average binder reagent injected in kg per foot injected per vertical foot of DSM-LCC vs. depth in feet.

**2. Shop Plan/Working Drawing:**

The Shop Plan/Working Drawing shall contain the location and extent of all production DSM columns that will be constructed as indicated in the plans. Indicate DSM column spacing and overlap dimensions, including overall dimensions of ground improvement area. Provide the production DSM column numbering system/identification for each location where DSM columns will be constructed. Provide the sequence of DSM column construction that will be used to minimize the effects of ground movements on adjacent existing structures (i.e. MSE walls). The Shop Plan/Working Drawing shall be prepared, signed, and sealed by a professional engineer licensed in the State of South Carolina.

**D. PRE-PRODUCTION FIELD AND LABORATORY TESTING**

A pre-production field and laboratory testing program will be required to develop the proposed DSM wet or dry binder mix design prior to the construction of the test section(s). The field testing program consists of conducting a geotechnical subsurface investigation in accordance with subsection D.1 of this special provision. Soil samples obtained from the geotechnical subsurface investigation shall be used to develop and conduct the pre-production laboratory testing. The pre-production laboratory testing will be required to establish a “base line” of the degree of ground improvement that is possible under optimal construction circumstances for various DSM binder mixes for each distinct soil type that will be encountered during the conduct of the DSM ground improvement. It is recognized that the pre-production laboratory testing will be used as a general indicator of ground improvement that may be obtained in-situ because of substantial differences inherent between laboratory and in-situ mixing conditions. The Contractor shall take appropriate account of these differences, based on published documents and the Contractor’s experience, to develop a DSM binder mix design that can be used for constructing the test section(s) based on the results of the pre-production laboratory testing. A pre-production laboratory testing program shall be required for each test section. A DSM binder mix design shall be developed for each major soil type encountered throughout the depth of ground improvement. As a minimum, two binder mix designs for two types of soil shall be required per test section. The minimum pre-production laboratory testing requirements for wet and dry mixing methods are provided in subsections D.2 and D.3 of this special provision, respectively.

The Contractor shall submit the geotechnical subsurface investigation plan of the proposed field sampling and laboratory testing to the Engineer for review and approval a minimum of 14 calendar days prior to commencing the geotechnical subsurface investigation. The Contractor shall submit the results of the geotechnical subsurface investigation and the pre-production laboratory testing plan to the Engineer for review and approval a minimum of 14 calendar days prior to commencing the pre-production laboratory testing. The results of the pre-production field and laboratory testing along with the proposed DSM binder mix designs shall be included in the DSM Installation Plan submittal in accordance with section C.

**1. Geotechnical Subsurface Investigation:**

In-situ soils used for the pre-production laboratory testing shall be obtained from additional subsurface investigation conducted at or near the location of the approved test section(s) locations. The Contractor shall retain the services of a geotechnical consultant to drill several 3-inch continuously sampled soil borings to obtain sufficient material to perform the pre-production laboratory testing. The sampling shall be performed in such a manner that provides continuous, representative samples of the soil column. This can be effective

accomplished via Geo-probe sampling techniques, undisturbed sampling in fine-grained soils, split-spoon sampling, or any other sampling technique proposed by the Contractor and approved by the Engineer.

Contractor shall check for utility conflicts at boring locations with appropriate utility agencies, survey boring locations and survey locations tied to the project baseline alignment. The borings shall extend from the ground surface to the bottom elevation of the DSM columns shown in the plans to establish general soil and groundwater conditions in the vicinity of the work prior to construction of the test section(s). The geotechnical investigation shall be done in conformance with the latest version of the SCDOT Geotechnical Design Manual (GDM). SCDOT practices including but not limited to boring logs and laboratory data reporting shall be used. The geotechnical consultant shall classify and record soil types within 7 days of obtaining the samples in the field. The Geotechnical consultant shall perform laboratory testing on representative samples of the entire soil profile that will be subject to ground improvement. As a minimum, test six representative samples of cohesive soils taken from different locations and four representative samples of cohesionless soils taken from different locations. The laboratory testing, as a minimum, will consist of the following:

- a. Cohesive and organic soils (i.e. peat) will be subject to laboratory tests that include, but not be limited to, moisture content, Atterberg limits, organic content, and unconfined compression tests.
- b. Cohesionless soils will be subject to laboratory tests that include, but not be limited to, grain size analysis, fraction passing #200 sieve, Atterberg Limits, and moisture content.

All soil samples to be used for the pre-production laboratory testing shall be stored in a manner that prevents any loss of moisture and in accordance with ASTM. Do not allow field samples of the clay to lose moisture between the time of removal from ground and pre-production laboratory mixing/testing.

## 2. **Pre-Production Laboratory Testing.**

Pre-Production laboratory testing will require the development of a DSM binder mix testing program for each type of soil where ground improvement will be performed to demonstrate that the required 28-day compressive strength indicated in the plans will be achieved. The soils obtained from the geotechnical subsurface investigation performed (Subsection D.1) will be used to perform the laboratory testing. All soil and mixed samples shall be kept out of sunlight at 70 degrees F and under fully humid conditions throughout storage and curing that prevents loss of sample moisture via evaporation.

DSM constructed using the wet mixing method (DSM-SCC) will require that the testing laboratory prepare the soil, mix the binder reagent (i.e. cement, etc.) and water to make grout, and then mix grout and soil together. The specimens shall be mixed using a minimum of four different DSM binder mixes to provide insight into the relationship of cement factor and grout water/cement ratio on the 28-day compressive strength of the soil-binder specimens. Binder materials and individual proportions of cement or admixtures (if used) used shall be documented for each specimen. The procedures outlined by Filz and Stewart (2005) may be used to provide guidance in developing a laboratory testing program.

DSM constructed using the dry mixing method (DSM-LCC) will require that the testing laboratory prepare the soil, binder reagent, and then mix the soil (at the same in-situ moisture) and binder reagent together. The specimens shall be mixed using a minimum of four different DSM binder mixes to provide insight into the relationship of binder proportions on the 28-day compressive strength of the soil-binder specimens. Binder materials and individual proportions of lime, cement, and admixtures (if used) used shall be documented for each specimen. The procedures outlined by Jacobson et.al (2003, 2005) may be used to provide guidance in developing a laboratory testing program.

All test specimens shall be prepared using the lab mixing energy level similar to energy levels used by the Contractor's field equipment. Test specimen cylinders shall be prepared according to procedures submitted to the Department and approved. Strength test three cylinders of soil-binder mixture at 3, 7, 14, 28, and 56 days following mixing. Strength testing shall be performed in accordance with subsection H.4.

**E. DELIVERY, STORAGE, AND HANDLING OF MATERIALS**

**1. DSM Wet Mixing Method (DSM-SCC):**

Portland cement shall be measured, handled, transported, and stored in bulk in accordance with the manufacturer's recommendations. Portland cement packaged in cloth or paper bags shall be sealed with plastic or rubber vapor barriers. The Portland cement shall be stored to prevent damage by moisture. Materials that become caked due to moisture absorption shall not be used. Bags of cement shall be stacked no more than ten bags high to avoid compaction. Cement containing lumps or foreign matter of a nature that may be deleterious to the grout mixing or delivery or injection operations shall not be used.

**2. DSM Dry Mixing Method (DSM-LCC):**

The quicklime and cement shall be stored in closed pressure tanks suitable to be used as pressure vessels, for all pressures required, including those used to load and unload the materials. Delivery trucks shall be loaded at the manufacturer's plant unless approval is given for an intermediate storage facility. Each truck shall have a certified record of the weight of each load of material. The material shall be transported to the project site and blown into the on-site storage tanks using a pneumatic system. The air evacuated from the storage tanks during the loading process shall be filtered before being discharged to the atmosphere. A sealed refilling machine shall be used to transport material from the storage tanks to the DSM column mixing machine. This machine shall be refilled using a pneumatic system and an air filter, as specified above.

**F. INSTALLATION EQUIPMENT**

The DSM column construction equipment and support equipment shall be equipped with mixing tools that are capable of thoroughly blending the in situ soils and binder material into a homogeneous column of soil-binder to the depths and size required in the plans. The equipment shall be capable of advancing through previously installed and cured DSM columns as necessary for installing overlapping and end junction DSM columns. The DSM columns shall be constructed using computerized self-contained construction equipment.

**1. DSM- SCC Construction Equipment:**

The DSM-SCC construction equipment shall meet the following requirements:

- a. DSM-SCC shall be constructed using real-time computerized self-contained DSM-SCC construction equipment capable of monitoring, controlling, and recording installation data. The DSM-SCC construction equipment shall be equipped with electronic sensors, built into the soil mixing equipment, to perform the following:
  - 1) Determine vertical alignment of the leads in two directions: fore-aft and left-right. The verticality shall be measured using instrumentation that is capable of measure deviations from verticality to an equivalent of 1-inch in 100-feet.
  - 2) Monitor cement and water proportioning, grout mixing, and water-cement ratios.
  - 3) Monitor the mixing tool depth and penetration/withdrawal speed, and mixing tool rotation speed.
  - 4) Monitor mixing tool withdrawal speed, and mixing tool rotation speed.
  - 5) Monitor injection quantities and pressure with flow meter and other measuring equipment having precision accuracy not less than 99.5 percent.
  - 6) All output from the sensors shall be routed to a console that is visible to the operator and the Engineer during penetration and withdrawal.



## EXHIBIT 5 – SPECIAL PROVISIONS AND CONTRACT REQUIREMENTS

- 7) The sensors shall be calibrated at the beginning of the project and calibration data provided to the Engineer. The calibration shall be repeated at intervals not to exceed one month.
  - 8) All of these monitored functions shall be fully adjustable during operation of the equipment.
- b. The DSM-SCC construction equipment power source for driving the mixing tool shall be sufficient to maintain the required revolutions per minute (RPM) or injection pressure and penetration rate from a stopped position at the maximum depth required as determined from the test section(s) for group and/or block DSM column spacing. The Contractor shall also consider the wide range of expected subsurface conditions, indicated by the available geotechnical information.
  - c. The DSM-SCC construction equipment shall utilize sufficient mixing and injecting equipment to adequately produce a homogeneous distribution of cement grout throughout the mixed in-situ soils that meet the acceptable criteria. The mixing tools shall uniformly inject cement grout through hollow stem or other piping at locations that distribute the grout across the full diameter of the mixing tools and such that the full auger/mixing paddle assembly passes through the column of soil after the grout is introduced, on both the insertion and withdrawal strokes. Grout shall only be injected in direction within the diameter of the augers or mixing paddles. If grout injection jets are used, they shall not spray beyond the auger diameter.
  - d. Continuous auger flights longer than 3 feet or with more than one full, uninterrupted revolution of auger are not allowed as part of the mixing tools. Auger flights and mixing paddles on a shaft shall all reach to the full column diameter, and shall have discontinuous lengths and be so oriented as to thoroughly break up the in-situ soils, and disperse and blend soils with injected cement grout to form a homogeneous soil-cement mixture.
  - e. The auger mixing equipment shall form the required diameter and size of the DSM-SCC as submitted by the Contractor's approved submittals.
  - f. Injection volume estimates shall be only made by precision inline flow meters. Counting or measuring grout pump strokes shall not be acceptable. Injection quantities must be measured in real time by direct measurements of volume and/or mass for each DSM column having injection capabilities, with flow meters and other measuring equipment having precision accuracy not less than 99.5%. Gages and flow meters and other measuring equipment shall be calibrated and certified as precise and accurate before the start of the equipment's work on the project, and then again every 4 months.
  - g. The DSM-SCC construction equipment shall be adequately marked to allow the Engineer to confirm the penetration depth to within 6 inches during construction.
  - h. The cement grout batching plant shall include all storage silos and sheds, pumps, scales, mixers, valves, gauges, and regulating devices required to continuously measure and mix cement grout in real time. Grout shall be mixed in a mixing plant, using a batch process, which combines dry materials and water in predetermined proportions. The plant mixer shall consist of grout mixer, grout agitator, grout pump, automatic batching scales, and a computer control unit. The mixing plant shall meet the following requirements:
    - 1) To accurately control grout mix proportions, the addition of water and cement shall be determined by weight using automatic batch scales in the mixing plant.
    - 2) Admixtures, if used, may be delivered to the mixing plant by calibrated auger provided the Contractor can demonstrate that the auger can deliver the material at the same accuracy as by weight.
    - 3) The mixing components shall be calibrated prior to beginning the work and monthly thereafter. The calibration data shall be provided to the Engineer.
    - 4) The mixing plant shall have tanks or silos with adequate storage for continuous production. The tanks shall be equipped with air filters.

## EXHIBIT 5 – SPECIAL PROVISIONS AND CONTRACT REQUIREMENTS

- i. Positive displacement pumps shall be used to transfer the grout from the mixing plant to the mixing tool. If the DSM-SCC construction equipment has multiple shafts, and multiple mixing tools, the grout shall be delivered to each shaft by an individual positive displacement pump.
- j. All gauges, flow meters, metering equipment, and other measuring equipment shall be calibrated and certified as precise and accurate before starting DSM column construction (i.e. test section(s) or production DSM columns), and then again every 4 months or at least every 325,000 feet of DSM column installed, whichever is sooner. The calibrations and certifications shall be supplied to the Engineer.

### 2. **DSM- LCC Construction Equipment:**

The DSM-LCC construction equipment shall meet the following requirements:

- a. DSM-LCC shall be constructed using real-time computerized self-contained DSM-LCC construction equipment capable of monitoring, controlling, and recording installation data. The DSM-LCC construction equipment shall be equipped with electronic sensors, built into the soil mixing equipment, to perform the following:
  - 1) Determine vertical alignment of the leads in two directions: fore-aft and left-right. The verticality to an equivalent of 1-inch in 100-feet
  - 2) Monitor the mixing tool depth, penetration/withdrawal speed, mixing tool rotation speed, and injection pressure
  - 3) All output from the sensors shall be routed to a console that is visible to the operator and the Engineer during penetration and withdrawal
  - 4) The sensors shall be calibrated at the beginning of the project and calibration data provided to the Engineer. The calibration shall be repeated at intervals not to exceed one month
  - 5) An alternative display/monitoring system may be used subject to review and approval by the Engineer prior to use
  - 6) All of these monitored functions shall be fully adjustable during operation of the equipment
- b. The DSM-LCC construction equipment power source for driving the mixing tool shall be sufficient to maintain the required revolutions per minute (RPM) or injection pressure and penetration rate from a stopped position at the maximum depth required as determined from the test section. The Contractor shall also consider the wide range of expected subsurface conditions, indicated by the available geotechnical information.
- c. The DSM-LCC construction equipment shall be adequately marked to allow the Engineer to confirm the penetration depth to within 6 inches during construction.
- d. All gauges, flow meters, metering equipment, and other measuring equipment shall be calibrated and certified as precise and accurate before the starting DSM column construction (i.e. test section(s) or production DSM columns), and then again every 4 months or at least every 325,000 feet of DSM column installed, whichever is sooner. The calibrations and certifications shall be supplied to the Engineer.

### **G. CONSTRUCTION REQUIREMENTS**

The Contractor shall furnish all materials, labor and equipment necessary to construct the DSM columns in accordance with the plans and specification. The DSM columns shall be constructed to the lines, grades, and cross sections indicated in the Plans. The completed DSM improved zone shall be a homogeneous mixture of binder material constructed in accordance with the method of mixing and column spacing indicated in the plans.

Production DSM shall be constructed using the same equipment and construction criteria (i.e. mix design, mixing parameters, etc.) established in the accepted test section construction (subsection I). DSM construction that is out of tolerance (subsection G.4) or is subject to unforeseen conditions (subsection G.5) shall be evaluated and corrected as approved by the Engineer with no additional cost or schedule impact to the Department.

**1. Site Preparation:**

The presence and location of buried pipes, sewers, and other utilities shall be identified and precautions taken to protect the utilities from damage during the construction of the DSM columns. The Contractor shall be responsible for any damage resulting from the construction of the DSM columns. The site shall be cleared and grubbed in accordance with the Contract documents. Limit grubbing to that needed to remove previous construction materials, trees, stumps, and large roots. Fill in holes left by construction materials, stumps and root extraction and grade to provide level working surface. Place bridge lift materials as required in the plans and contract documents.

Establish DSM column limits and locations by a licensed surveyor. Individual column locations shall be marked. Sufficient horizontal and vertical control shall be provided to establish that DSM columns are located accurately and reach the required plan depths.

**2. DSM-SCC Soil-Grout Mixing:**

Soil shall be broken up and blended with grout in place by the pugmill type action of the soil mixing equipment. The completed DSM-SCC shall be a uniform mixture of cement and the in situ soils. The soil-grout mixture shall achieve an average unconfined compressive strength in 28 days as indicated in the plans. Soil mixing shall be performed with the following minimum requirements:

- a. *Grout Preparation:* The dry materials shall be fed to the mixers for agitation and shearing. The mixing ratio of the grout shall be controlled by measuring the weight of grout components using automatic batch scales in the mixing plant. Grout mixture shall be mixed for a minimum of three minutes, with a maximum holding time of two hours, calculated from the beginning of initial mixing. The specific gravity of the grout (determined in the test section) shall be tested at least once per shift per rig, using the methods outlined in ASTM D 4380, and shall not deviate more than three percent from the calculated specific gravity for the design cement ratio. Additional tests may be required by the Engineer. If the specific gravity or density is lower than the design mix, the Contractor shall add additional cement, remix, and/or recalibrate batch scales and retest the grout until the design density is achieved, at no additional cost to the Department.
- b. *Grout Injection:* The grout shall be pumped through and injected from the mixing tool. The grout injection rate per vertical foot of DSM-SCC shall be in accordance with the requirements of the design mix established during the test section. Injection rates falling below this requirement, shall require the DSM-SCC to be remixed and additional grout injected (at the design grout-soil ratio) to a depth at least three feet below the deficient zone, at no additional cost to the Department. The Contractor may sample using wet grab methods for his own purposes. The Department will not accept results from wet sampling for quality control purposes.
- c. *Rotation Speeds:* The mixing tool rotational speeds (measured in RPM) and penetration/withdrawal rates shall be in accordance with the parameters established during the test section(s). If these parameters are varied more than 15 percent from those determined during the test section(s), the DSM-SCC section shall be remixed while injecting grout at the design grout ratio to a depth at least three feet below the deficient zone, at no additional cost to the Department.
- d. *On-Board Computer:* The preset data in the on-board computer shall be verified for each column as correct and adjusted if necessary. The operator shall monitor and adjust as necessary during column installation the feeding of material, the grout injection rate, the mixing tool rates of rotation, and penetration/withdrawal rates of the mixing tool.
- e. *Changes in Grout Mix Design:* The Contractor may request that the established grout mix be modified during the production DSM-SCC installation. To verify acceptable results

for the modified mix design, the Engineer may require additional testing or a new test section, at no additional cost to the Department.

- f. *Spoils:* During the course of soil-cement stabilization, return/spoil material shall not be dumped into or otherwise be allowed to enter the soil-cement column. The Contractor shall develop a spoil containment system that allows the channeling of the spoils to the temporary holding pit in such a direction and manner as to keep the spoils away from the site perimeter, and out of the traveled paths. Soil-cement return and spoil material shall be piped or channeled to holding ponds or other retention structures within the work area. The Contractor shall remove all excess grout and grout mixed soil generated from ground improvement activities from the construction site in accordance with the approved DSM Installation Plan.

The Contractor shall take all necessary precautions and implement measures to prevent any soil-cement return, other spoil material or stockpiled materials from entering storm drain structures, drainage courses, other utility lines, or from leaving the site via surface runoff. The Contractor shall prevent soil-cement return, fluid, ponded spoil material, or stockpiled solidified materials from migrating into any water body. In the event soil-cement return, spoil material or stockpiled materials enter storm drain structures, drainage courses, or other utilities, including, but not limited to, surface water bodies beyond site limits of soil-cement mixing operations, the Contractor shall collect and remove all of these materials, and perform all other required/necessary remediation that may be directed by the Engineer or responsible environmental agency, at no additional cost or schedule impact to the Department. The Contractor shall conduct all soil-cement operations to conform to sedimentation and turbidity control requirements of federal, state, and local agencies having jurisdiction over the work.

- g. *Delays:* The installation of each DSM-SCC column shall be continuous without interruption. If an interruption of more than two hour occurs, the DSM-SCC shall be remixed for the entire column height using fresh cement grout as though there had not been any cement grout installed, or the column may be abandoned, at no cost or schedule impact to the Department. The Contractor shall install additional columns if the interrupted columns cannot be acceptably remixed.
- h. *Instability:* Soil-cement column which exhibits partial or total instability at any time, or collapses as a result of mechanical failure of any equipment; inadequacy of cement, water supplies, cement grout; improper drilling, injection or mixing procedures; or other cause, the Contractor shall halt DSM-SCC construction and backfill to ground surface with cement grout. After the backfill has attained sufficient strength to stabilize the ground, complete the required installation by re-drilling from ground surface, at no additional expense to the Department. The Engineer will evaluate the potential impacts of the instability and may require one or more additional re-drilled columns at overlapping or adjacent locations as determined by the Engineer, and at no additional expense to the Department.
- i. *Daily Quality Control Report:* The Contractor shall submit a Daily Quality Control Report for each day that DSM-SCC work is performed. The log shall contain as a minimum the information listed in Section C. The report shall be delivered to the Engineer by the end of the next working day following the report date.
- j. *Protective Covers:* Immediately after completing a soil-cement column, the Contractor shall install protective covers to prevent persons from falling or stepping into the unhardened soil-cement column.

**3. DSM-LCC Soil-Binder Mixing:**

Soil shall be broken up with the mixing tool. As the mixing tool is raised the binder material (i.e. lime-cement or cement) is injected using air pressure. The binder-soil mixture shall achieve an average unconfined compressive strength in 28 days as indicated in the plans. Soil mixing shall be performed with the following minimum requirements:

## EXHIBIT 5 – SPECIAL PROVISIONS AND CONTRACT REQUIREMENTS

- a. *Binder Injection:* The binder (i.e. lime-cement or cement) volume flow rate per vertical foot of DSM-LCC shall be in accordance with the requirements of the design mix established during the test section. Injection rates falling 10 percent below this requirement, shall require the DSM-LCC to be remixed and additional binder injected (at the design rate) to a depth at least three feet below the deficient zone, at no additional cost to the Department.
  - b. *Rotation Speeds:* The mixing tool rotational speeds (RPM) and the penetration/withdrawal rates shall be in accordance with the parameters established during the test section(s). If these parameters are varied by more than 15 percent from those determined during the test section(s), the DSM-LCC section shall be remixed using the design binder volume flow rate to a depth of at least three feet below the deficient zone, at no additional cost to the Department.
  - c. *On-Board Computer:* The preset data in the on-board computer shall be verified for each column as correct and adjusted if necessary. The operator shall monitor and adjust as necessary during DSM column installation the feeding of material, the injection air pressure, and the rates of rotation and rise.
  - d. *Changes in Binder Mix Design:* The Contractor may request that the established mixing parameters be modified during the production DSM-LCC installation. To verify acceptable results for the modified parameters, the Engineer may require additional testing or a new test section, at no additional cost to the Department.
  - e. *Delays:* The installation of each DSM-LCC column shall be continuous without interruption. If an interruption of more than two hours occurs, the DSM-LCC shall be remixed for the entire column height using design binder rates as though there had not been any binder installed, or the column may be abandoned, at no cost or schedule impact to the Department. The Contractor shall install additional columns if the interrupted columns cannot be acceptably remixed.
  - f. *Daily Quality Control Report:* The Contractor shall submit a Daily Quality Control Report for each day that DSM-LCC work is performed. The log shall contain as a minimum the information listed in Section C. The report shall be delivered to the Engineer by the end of the next working day following the report date.
4. **DSM Column Construction Tolerances:**
- a. *Horizontal Alignment:* The location of the DSM column shown in the Plans shall be accurately staked by a licensed surveyor before beginning installation. The horizontal alignment of DSM columns with group column spacing (GCS) shall be within 4 inches of the planned DSM top location. The horizontal alignment of DSM columns with block column spacing (BCS) shall be within 20 percent of the DSM column diameter, not to less than four inches, of the planned DSM top location in order to obtain sufficient DSM column overlap.
  - b. *Vertical Alignment:* The equipment operator shall control vertical alignment of the equipment and constructed DSM column. Two measures of verticality shall be monitored, longitudinal and transverse to the DSM column alignment. The DSM column shall be installed at an inclination that deviates no more than 1:100 (horizontal to vertical).
  - c. *DSM Column Lengths:* The tops of the DSM columns shall begin at the ground surface. The top of DSM column elevations shown in the plans are approximate. Natural soils above the water table, at the completion of DSM installation, shall have been treated to produce the full column design strengths up to within 3 feet of the ground surface. If the top of the DSM columns is being constructed within a surcharge or berm, the top of DSM column elevations shown in the plans shall be used.
- The bottom of DSM columns shall extend to the line and grades shown in the plans. The DSM column bottom elevations indicated in the Plans provide the minimum required penetration of the DSM columns. The Engineer may require the Contractor to shorten or deepen the bottom of DSM columns indicated in the plans.

d. *DSM-LCC Width*: When DSM columns are constructed using group column spacing (GCS) the DSM column diameter shown in the plans shall be the minimum required diameter. The diameter of DSM columns constructed using block column spacing (BCS) may vary to accommodate variations in the Contractor's equipment dimensions, provided that the plan area of ground improvement does not exceed the dimensions shown in the Plans more than six inches and is approved by the Engineer.

**5. Unforeseen Conditions and Corrective Remediation:**

Unforeseen conditions that result in deficient DSM column construction shall be remediated by the DSM Contractor at no additional cost to the Department. DSM column construction deficiencies and how they were addressed shall be noted in the DSM Daily Production Control Report and Installation Log. DSM column deficiencies that result from changes in rotation speeds of mixing tools, rate of penetration/withdrawal of mixing tools, changes in the rate of grout/binder injection, delays, or changes in binder mix shall be corrected as indicated in subsections G.2 and G.3 for DSM-SCC mixing and DSM-LCC mixing, respectively.

If unforeseen conditions result in DSM column interruptions that do not meet the DSM construction requirements (subsections G.2 or G.3), the DSM column installation shall be re-drilled a minimum of 1 foot below the elevation of the interruption and the DSM column construction restarted.

When interruption of the installation process occurs because of unknown obstructions or a very dense layer above the planned tip elevation, the Contractor shall document the interruption on the DSM Daily Production Control Report and Installation Log and notify the Engineer in writing by the end of that day of such encounter and shall provide all pertinent information relating to DSM column identification, plan location coordinates, depth, and expected extent of the obstruction. The Contractor shall be prepared to penetrate very dense layers by first removing mixing tools from the excavation and then using auger drilling equipment or other approved methods to allow the installation of the DSM column. When unknown obstructions are encountered, the Contractor shall submit a proposal to the Engineer for review that delineates the Contractor's proposed means and methods to overcome the unknown obstruction, including equipment and labor time estimated for this operation. Such construction to remove an unanticipated obstruction shall only be performed with the written authorization of the Engineer. When the obstruction cannot be penetrated or removed, the DSM column shall be completed to the maximum depth penetrated. The need for an alternate design or remedial construction shall then be determined by the Engineer.

Deficient DSM columns due to out of tolerances (subsection G.4) or not in compliance with DSM construction acceptance (subsection G.6) will require that the DSM Contractor to submit proposed remedial measures to the Engineer for review and approval. Remedial plans shall show the location, depth, construction exceptions requested, and proposed method of remediating the deficient DSM ground improved areas. Remedial plans, if accepted, shall be at no cost or schedule impact to the Department.

**6. DSM Construction Acceptance:**

The QC reporting (logs), testing, and acceptance procedures for the DSM test section(s) and production DSM columns shall be the same. QC testing methods are described in Section H and Acceptance Criteria are provided in Section K.

**H. DSM TESTING METHODS**

QC testing of DSM columns consists of using field and laboratory testing techniques to evaluate the integrity, consistency, and strength of the DSM column for the entire full depth of soil improvement. QC testing methods that will be used include probe testing (subsection H.1), soil borings and undisturbed sampling with Shelby tubes (subsection H.2), and coring and sampling (subsection H.3). Samples obtained by undisturbed sampling with Shelby Tubes or coring shall have samples tested for compressive strength testing (subsection H.4). DSM testing shall be

conducted in accordance with the SCDOT Geotechnical Design Manual, version 1.1 (2010), or later.

The results of the compressive testing shall be used to develop correlations for use with probe testing and therefore improve the reliability of the probe testing results. This will be accomplished by performing continuous undisturbed Shelby tube sampling and/or coring in one quadrant of the DSM column and probe testing in another quadrant of the same DSM column.

Any of the DSM testing methods presented may be used on production DSM columns to evaluate deficiencies based on construction records or field observations.

**1. Probe testing:**

- a. Probe testing shall be conducted using the seismic cone penetrometer test with pore pressure measurements (SCPTu). The SCPTu testing results (i.e. tip resistance, friction sleeve resistance, pore pressure, and shear wave velocity vs. depth of penetration) shall be provided graphically and in electronic file format to the Engineer.
- b. Probe testing shall be performed in the presence of the Engineer, unless otherwise directed. The Contractor shall notify the Engineer at least seven calendar days in advance and confirmed 2-days (48 hours) prior to beginning SCPTu operations.
- c. The SCPTu testing shall be conducted in accordance with the SCDOT Geotechnical Design Manual.
- d. Probe testing shall be performed after the soil-binder mixture has hardened sufficiently, but before it has cured to the extent to cause refusal to the SCPTu equipment.
- e. Unless directed otherwise by the Engineer, probe tests shall be performed along an essentially vertical alignment located within one of the quadrants of the DSM column and shall include inclinometer measurements that confirm the verticality of the SCPTu test data such that the entire probe test is determined to have been advanced within the DSM column. The SCPTu shall be taken at a distance of 2/5 the DSM column radius from the center of the DSM column.
- f. If seismic cone shear wave testing results are inconclusive, the SCPTu may be discontinued and cone penetrometer test with pore pressure measurements (CPTu) may be used with written approval from the Engineer.
- g. The CPT testing equipment shall be sized to allow full penetration and testing to the depth of the planned test DSM column plus 10 feet.
- h. If standard full-size CPT truck equipment (i.e. 20-30 ton reaction truck) is not capable of testing to the desired depths, the Contractor shall conduct SPT testing in accordance with the SCDOT Geotechnical Design Manual, at no additional cost to the Department. SPT shall be conducted on a maximum five foot center interval to the depth of the planned test DSM column plus 10 feet.
- i. All probe test holes shall be filled with cement grout that will obtain 28-day strength equal to or greater than the DSM column compressive design strength required in the plans.

**2. Soil Borings and Undisturbed Sampling:**

- a. Soil borings and undisturbed Shelby tube sampling shall be performed in the presence of the Engineer, unless otherwise directed. The Contractor shall notify the Engineer at least seven calendar days in advance and confirmed 2-days (48 hours) prior to beginning soil boring operations.
- b. Soil borings and sampling shall be conducted in accordance with the SCDOT Geotechnical Design Manual.

## EXHIBIT 5 – SPECIAL PROVISIONS AND CONTRACT REQUIREMENTS

- c. High quality undisturbed sampling shall be obtained after the soil-binder mixture has hardened sufficiently to a minimum compressive strength of 3 psi (430 psf) but not greater than 55 psi (7,900 psf).
  - d. Unless directed otherwise by the Engineer, soil borings shall be obtained along an essentially vertical alignment located within one of the quadrants of the DSM column. The soil boring shall be taken at a distance of 2/5 the DSM column radius from the center of the DSM column.
  - e. Sampling shall be conducted using a thin wall Shelby tube sampler and/or pitcher barrel sampler in accordance with the SCDOT Geotechnical Design Manual.
  - f. Upon Shelby tube retrieval, the samples shall be logged visually without extraction of the samples from the Shelby tube and sealed to prevent loss of moisture during transport.
  - g. Undisturbed samples shall be transported by the Contractor to the independent AASHTO certified materials testing laboratory where the samples will be extracted, stored, and tested.
  - h. Upon extraction of the samples at the independent materials testing laboratory, the samples shall be logged and documented by taking pictures. The percent recovery per Shelby tube sampler based on the sampler penetration shall be documented. Samples shall be selected for testing and submitted to the Engineer for approval. Samples shall be stored and cured in accordance with ASTM D 1632 until the test date.
  - i. All soil boring holes shall be filled with cement grout that will obtain 28-day strength equal to or greater than the DSM column compressive design strength required in the plans.
3. **Coring and Sampling:**
- a. Coring/sampling shall be performed in the presence of the Engineer, unless otherwise directed. The Contractor shall notify the Engineer at least seven calendar days in advance and confirmed 2-days (48 hours) prior to beginning coring/sampling operations.
  - b. High quality continuous core sampling shall be obtained after the soil-binder mixture has hardened sufficiently to approximately a compressive strength of 42 psi (6,050 psf).
  - c. Unless directed otherwise by the Engineer, core runs shall be obtained along an essentially vertical alignment located within one of the quadrants of the DSM column. The core run shall be taken at a distance of 2/5 the DSM column radius from the center of the DSM column.
  - d. Coring shall be conducted using double or triple tube samplers to obtain samples of 2.5 inches in diameter or greater. Triple tube core barrel may be required by the Engineer, at no additional cost to the Department, if the sample quality of the double tube core barrel is not providing high quality samples suitable for compression strength testing.
  - e. Each core run shall be at least four feet in length and contain at least four acceptable test specimens. Three samples per core run are required to perform compressive strength testing with one reserve sample.
  - f. A minimum core run recovery of 85 percent for each 4-foot-long core run shall be achieved. During coring, the elevation of the bottom of the holes shall be measured after each core run in order that the core recovery for each run can be calculated. The core recovery and RQD for every core run shall be reported in the logs. Additional cores may be required, at no additional cost to the Department, if core run recovery is less than 85 percent.
  - g. Upon retrieval, the samples shall be field logged and documented by taking pictures. Samples shall be selected for testing and submitted to the Engineer for approval.
  - h. Following logging and test specimen selection, the entire full-depth sample, including the designated test specimens, shall be immediately sealed in plastic wrap to prevent drying, placed in suitable core boxes, and transported to the materials testing laboratory by the Contractor within 24 hours.



## EXHIBIT 5 – SPECIAL PROVISIONS AND CONTRACT REQUIREMENTS

- i. All core holes shall be filled with cement grout that will obtain 28-day strength equal to or greater than the DSM column compressive design strength required in the plans.
  - j. Cores shall be transported by the Contractor to the independent AASHTO certified materials testing laboratory where the samples will be stored and tested. Samples shall be stored and cured in accordance with ASTM D 1632 until the test date.
- 4. Strength Testing of Samples:**
- a. All samples shall be kept out of sunlight at 70 degrees F and under fully humid conditions throughout storage and curing that prevents loss of sample moisture via evaporation.
  - b. Samples suitable for strength testing shall have a height to diameter ratio of 2.0.
  - c. Strength testing shall be performed by unconfined compression testing method per AASHTO specification T-208-96, but with strain rate not faster than 0.5% per minute, but not slower than 0.25%/minute, and with test equipment set up to record in both tabular and graphical form the axial stress and strain constant increments of axial strain no larger than every 0.05% axial strain. The Contractor will be permitted to perform UU Triaxial Compressive Tests, with approval of the Engineer, in lieu of performing unconfined compressive strength test, at no additional cost to the Department.
  - d. Compressive strength testing results shall be transmitted to the Engineer for review within 24 hours of the compression test completion. The remaining portions of the full-depth samples that are not tested shall be retained by the Contractor, until completion and acceptance of the work, for possible inspection and confirmation testing by the Engineer.

**I. DSM TEST SECTION AND QC TESTING PROGRAM**

The QC testing program for each test section will be submitted to the Engineer within 5 days after test section DSM column installation and shall be based on the results of DSM pre-production laboratory testing, early probe testing (3 and 5 days after column installation), and review of samples obtained for strength testing. The approved compressive strength testing program (i.e. Plan location, sample depth, and elapsed time after construction to perform compressive testing) shall then be submitted to the Contractor's independent AASHTO certified laboratory testing firm.

Unless otherwise directed by the Engineer, a minimum of four Plan locations shall have QC testing, per test section. QC testing at each Plan location shall consist of full-depth continuous soil borings or corings per subsections H.2 and H.3, respectively. Soil boring or coring sampling shall be performed in one DSM column quadrant, while probe testing, per subsection H.1, shall be performed in another DSM column quadrant. A minimum of six samples at each QC testing Plan location shall be selected by the Contractor and approved by the Engineer for compressive strength testing. Compressive strength testing of cores (subsection H.4) and probe testing (Section H.1) at QC testing Plan locations shall be conducted at 7, 14, 28, and 56 days after test DSM column installation. The results of the compressive testing shall be used to develop correlations for use with probe testing and therefore improve the reliability of the probe testing results. A test DSM column compressive strength testing report shall be compiled by the independent testing company and submitted to the Contractor and the Engineer. The compressive strength testing report shall document the soil boring/core sampling and compressive strength testing conducted on the cores.

In addition to probe testing conducted at QC testing Plan locations, full depth probe testing shall be conducted at two separate plan locations within the test section in separate DSM column quadrants at 3, 7, 14 and 28 days after test DSM column installation. A probe testing report shall be compiled of all testing results in accordance with Section G.2.

The Contractor shall use the results of the test sections to establish the DSM production construction criteria. The DSM production construction criteria shall be developed to produce DSM columns that meet the Acceptance Criteria in Section K. DSM production construction criteria for DSM columns shall include as a minimum, the following criteria.

## EXHIBIT 5 – SPECIAL PROVISIONS AND CONTRACT REQUIREMENTS

DSM-SCC Production Construction Criteria:

1. Grout mix design including ratios of all materials mixed to form the grout
2. Grout specific gravity
3. Grout injection rates
4. Type of equipment
5. Mixing tool penetration and withdrawal rates
6. Mixing tool rotation speed
7. Construction procedures and techniques

DSM-LCC Production Criteria:

1. Binder mix design including ratios of all materials (i.e. lime-cement or cement) mixed to form the soil-binder material
2. Lime-cement injection rates
3. Type of equipment
4. Mixing tool penetration and withdrawal rates
5. Mixing tool rotation speed
6. Construction procedures and techniques

The Contractor shall use the results of the test sections to establish the Production Quality Control (QC) testing program per Section J.

Construction of production DSM columns may begin only after written acceptance by the Engineer of the “DSM Production Construction Criteria” and the “Production Quality Control (QC) Testing Program.” If construction criteria, construction procedures, equipment, new mobilizations, or changes in personnel are made, following acceptance of the test sections, the Department reserves the right to require the Contractor to construct a new test section at no additional cost to the Department.

### **J. PRODUCTION QC TESTING PROGRAM**

The Production QC Testing program shall be developed by the Contractor and approved by the Engineer. The Production QC Testing program will be required to include probe testing per subsection H.1 and strength testing of samples per subsection H.4. The following minimum requirements shall be used to developing the Production QC Testing Program:

DSM QC Testing Program Minimum Requirements:

1. The Production QC Testing Program goal is to establish continuity/integrity of the columns and to obtain a measure of their strength. This is accomplished by using the QC Testing to evaluate if the DSM ground improvement is meeting the Acceptance Criteria in Section K.
2. Provided that acceptable correlations can be developed between probe testing and compression strength testing, QC probe testing per subsection H.1 shall be performed at a minimum frequency of 5 percent of production columns (1:20) but not less than 1 QC probe test for every 200 cubic yards of DSM stabilized volume.
3. One Soil boring/Coring full depth of DSM columns plus 10 feet with a minimum of one strength test per 5 feet of penetration of stabilized soil (Section H) shall be obtained adjacent to probe testing (adjacent DSM quadrant) at a minimum frequency of 0.5 percent of production columns (1:200) but not less than 1 QC probe test for every 2,000 cubic yards of DSM stabilized volume.

## EXHIBIT 5 – SPECIAL PROVISIONS AND CONTRACT REQUIREMENTS

4. If acceptable correlations cannot be developed between probe testing and compression strength testing, one Soil boring/Coring full depth of DSM columns plus 10 feet with a minimum of one strength test per 5 feet of penetration of stabilized soil (Section H) shall be obtained adjacent to probe testing (adjacent DSM quadrant) at a minimum frequency of 1.0 percent of production columns (1:100) but not less than 1 QC probe test for every 1,000 cubic yards of DSM stabilized volume.
5. The QC Testing program shall define the limits of the production DSM testing based on the number of rigs operating, anticipated production schedule, and the minimum QC testing criteria defined above.
6. The QC Testing program shall include provisions for revising QC testing frequency as a result of failing DSM Acceptance Criteria, changes in construction criteria, construction procedures, equipment changes, new mobilizations, or changes in personnel that are made following acceptance of the test sections.
7. The Department reserves the right to require the Contractor to perform additional QC testing after review of the daily Quality Control Report/Log of the production DSM columns and/or review of QC Testing results. Although coring and conducting compressive strength testing of cores (Section G.1) is not intended to be a routine QC testing method, the Engineer reserves the right to use this QC testing method based on the results of the probe testing at any time.
8. The Contractor shall determine the time interval between DSM installation and QC testing. QC testing shall be performed on columns cured for a minimum of 3 days but no longer than 28 days, or as directed by the Engineer.
9. Only probe testing equipment and methods that have been calibrated during the test section shall be used for QC testing. If production DSM columns are being installed differently from the test section DSM column installation, a calibration of the probe testing with coring and compression testing shall be required unless approved otherwise by the Engineer.

### **K. ACCEPTANCE CRITERIA**

Determination that the DSM columns meet the Acceptance Criteria (for DSM construction, DSM column continuity, and DSM compressive strength requirements) shall be evaluated solely by the Engineer based on a review of daily Quality Control Report/Log of the production DSM columns and QC testing results conducted by an independent testing company.

#### **1. DSM Construction Acceptance Criteria:**

DSM columns shall be considered acceptable when daily Quality Control Report/Log of the production DSM columns and any remediation reports indicate that the:

- a. Location of the top of the columns has been verified to be within design tolerances
- b. Penetration of the column has been verified as correct by the Engineer.
- c. Continuously recorded injection quantity of cement grout for DSM-SCC and binder (lime-cement or cement) for DSM-LCC columns has been verified to be within 10% of the design (preset) value established for the production DSM construction criteria based on the results of approved production DSM construction design criteria.

#### **2. Evaluation of DSM Column Continuity:**

Lumps of unimproved soils shall not amount to more than 15 percent of the total volume of any 4-foot section of continuous full-depth evaluation by either conducting continuous probe testing, soil borings, or coring. Any individual or aggregation of lumps of unimproved soil shall not be larger than 6 inches in greatest dimension. For evaluating the volume of unimproved lumps of soil, all of the unrecovered samples shall be assumed to be unimproved soil. In addition, within a sample, the sum length of unmixed or poorly mixed soil regions or lumps that extend entirely across or a portion thereof the diameter of the sample will be considered unimproved.

**3. Design Compressive Strength Acceptance:**

Unless directed otherwise by the Engineer, all DSM QC compressive strength test results shall indicate a minimum of 60 percent of the design compressive strength at 5 days or less. Failure to meet this criterion shall deem the DSM column to be in non-conformance of the DSM compressive strength acceptance criterion. The DSM column shall be retested (same DSM column, different quadrant) at 28 days where the average QC strength testing shall indicate 100 percent or more of the compressive design strength with no sample testing less than 85 percent of the compressive design strength. Failure to meet the 28 day QC strength testing criterion shall deem the DSM column to be in non-conformance of the DSM compressive strength acceptance criteria. The Contractor may elect to conduct additional QC strength testing in excess of 28 days, with approval of the Engineer, at no additional cost to the Department. Unless otherwise determined by the Engineer, the extent of the non-conformance QC test area shall be considered to include all DSM constructed during all rig shifts that occurred after construction when passing tests were achieved. Non-conforming DSM QC test areas shall be remedied by the Contractor by conducting the following procedures.

The Contractor may conduct two or more additional QC probe tests (locations designated by the Contractor and approved by the Engineer) to better define the limits of the non-conformance and submit the results of those tests for review by the Engineer at no additional cost to the Department. If a minimum of 60 percent of the design strength has been achieved at 5 days or less, the Engineer shall evaluate the DSM construction documentation to determine which DSM columns are in conformance. If compressive strength criteria are achieved, with approval of the Engineer, all or a portion of the production DSM QC testing area may be approved provided that any deficient production DSM columns are remedied by one of the following two options. Failure to meet the required design strength of the additional DSM QC testing shall require that the DSM QC test area be remedied by one of the following options as approved by the Engineer.

- a. Provide 2 or more additional QC tests (locations designated by the Engineer) within the DSM QC test area which demonstrate that at 28 days, the average QC strength testing is 100 percent or more of the compressive design strength with no sample testing less than 85 percent of the compressive design strength.
- b. Re-drilling all or a portion of the nonconforming DSM QC test area and mixing additional cement grout for DSM-SCC columns or binder material (lime-cement or cement) for DSM-LCC, while raising the mixing tool. The Contractor shall submit a proposed plan for remixing or repair of failed sections for review and approval by the Engineer. Repair work of failed DSM columns shall be performed at no additional cost to the Department. Changing grout or binder quantities may require additional QC testing to calibrate QC probe testing. After reconstruction of the production DSM-LCC testing section, the affected DSM-LCC testing section will be subject to the compressive strength acceptance criteria as defined in this section.

**L. AS-BUILT PLANS**

Following completion of the production DSM column construction, the Contractor shall furnish to the Engineer a set of as-built plans detailing the locations of the DSM columns in terms of project coordinates, top and bottom elevations, QC compressive strength testing results, and any other dimensions of the DSM columns that are pertinent to the project.

**M. MEASUREMENT AND PAYMENT**

DSM constructed using group columns spacing (GCS) will be measured per linear foot of DSM column constructed and then accepted by the Engineer. DSM constructed using block column spacing (BCS) will be measured by the total neat-line ground improved volume (in cubic yards) accepted by the Engineer, where the neat-line is the rectangular plan area of the required ground improvement zone times the specified improvement depth. Material located outside of the tolerances specified will not be measured. Material used to remix an area found to be

**EXHIBIT 5 – SPECIAL PROVISIONS AND CONTRACT REQUIREMENTS**

unacceptable to the Engineer will not be measured. The test section(s) will not be measured, and is considered incidental to the production DSM ground improvement.

Payment will be made at the unit contract price per linear feet for DSM constructed using group columns spacing (GCS) and per cubic yard for DSM constructed using block column spacing (BCS). Payment for DSM columns will be full pay to perform the work as specified including construction and testing of test sections, QC testing, construction and removal of surcharges and berms, handling and hauling of excavated spoils, and site cleanup.

Payment will be made under:

<b>Item No.</b>	<b>Pay Item</b>	<b>Pay Unit</b>
2051201	GROUND IMPROVEMENT (DEEP SOIL MIXING SOIL-CEMENT COLUMNS – BCS)	CY
2051202	GROUND IMPROVEMENT (DEEP SOIL MIXING SOIL-CEMENT COLUMNS - GCS)	LF
2051203	GROUND IMPROVEMENT (DEEP SOIL MIXING LIME-CEMENT COLUMNS- BCS)	CY
2051204	GROUND IMPROVEMENT (DEEP SOIL MIXING LIME-CEMENT COLUMNS- GCS)	LF

**(34) SECTION 205: GROUND MODIFICATION – COMPACTION GROUTING COLUMNS:**

June 28, 2013

**A. GENERAL**

**1. Scope:**

The work under this Section consists of furnishing all supervision, labor, material, equipment, and related services necessary to perform ground improvement by the compaction grout technique as indicated on the Contract Drawings and specified herein.

For this project, the purpose of the compaction grouting is to reinforce the loose sand layers below embankments. The compaction grouting will serve to reinforce loose sand in the event of liquefaction during an earthquake.

The work includes the delivery and placement of all concrete/grout material necessary for compaction grouting construction.

**2. Compaction Grout Column Construction**

The work is to be accomplished using specifically-designed equipment for compaction grouting. The drill is to be advanced to the specified compaction grouting depth. Concrete/grout shall then be injected through the drill pipe as the pipe is being withdrawn, in such a way as to exert a positive lateral pressure on the soil surrounding the concrete/grout filled grout hole.

**3. Methods and Contractor Qualifications:**

The Specialty Contractor performing the compaction grouting installation shall be one who can provide a minimum 3-year experience record documenting 5 recent, successful projects completed with these general site conditions and improvement criteria. References asserting this documentation shall be submitted with the bid.

## EXHIBIT 5 – SPECIAL PROVISIONS AND CONTRACT REQUIREMENTS

A detailed description of the proposed construction method (including equipment and personnel) and the qualifications of the proposed Specialty Subcontractor shall be submitted with the bid.

#### 4. **References:**

American Society for Testing and Materials (ASTM) Standards

American Concrete Institute (ACI) Standards

Prior to commencing work, the Contractor shall examine the site, drawings, records or existing utilities and other existing subsurface structures, and soil boring logs made available by the Engineer to help determine compaction grouting installation conditions.

Any subsurface data provided by the Department is provided solely as general information for convenience of Contractor. It is expressly understood that the Department, Engineer, or the Engineer's consultants will not be responsible for interpretations or conclusions drawn there from by the Contractor. The Department and Engineer expressly encourage the Contractor to perform soil test borings or other subsurface explorations to determine whether the Contractor's proposed ground modification method is capable of installing the specified compaction grout columns. Additional test borings and other exploratory operations may be made by the Contractor at no additional cost to the Department.

#### 5. **Submittals:**

The following data shall be submitted for the approval of the Engineer prior to beginning of work.

- a. A detailed written procedure to be followed in installing the compaction grout columns and confirming that the specified work requirements have been achieved. The written procedure shall include a detailed description of the specialized equipment to be used.
- b. Proposed compaction grout design mix and descriptions of materials to be used. These shall be in sufficient detail to indicate their compliance with the specifications and either 1.) Laboratory tests of trial mixes made with the proposed mix or 2.) Laboratory tests of the proposed mix used on previous projects.
- c. The Contractor shall be responsible for providing all lines and grades for compaction grouting, including locations of all utilities and surveying markers.
- d. The Contractor shall be responsible for all health and safety requirements including those associated with the handling and disposal of contaminated materials. The Contractor shall be responsible for providing written procedures including a Health and Safety Plan.

#### 6. **Site Preparation:**

The Contractor shall ensure a firm base on which heavy equipment can be operated safely under its own power.

The Contractor shall accurately locate all compaction grout columns in accordance with approved drawings. Compaction grouting shall be adjusted, as approved by the Engineer, to avoid utilities, foundations, and all other underground construction.

The Contractor shall provide access and maintenance thereof, for the compaction grouting equipment, work force and delivery of materials to the work site.

### **B. PRODUCTS**

#### 1. **Materials:**

## EXHIBIT 5 – SPECIAL PROVISIONS AND CONTRACT REQUIREMENTS

- a. Portland Cement: Portland Cement shall conform to current ASTM standards, designation C 150. The use of cement replacement materials will be permitted subject to the approval of the Engineer and provided that they can be shown to have beneficial effects on concrete impermeability, heat generation during setting and general durability. The mix proportions of use shall be approved. For onsite batching, all cement and cement replacement materials shall be stored in separate containers according to type in waterproof stores or silos.
- b. Mineral Admixture: Mineral admixture, if used, shall be flyash or natural pozzolan which possesses the property of combining with the lime liberated during the process of hydration of Portland Cement to form compounds containing cementitious properties. The material shall conform to ASTM C 618, Class C or Class F.
- c. Fluidifier: Fluidifier shall be a compound possessing characteristics which will increase the fluidity of the mixture, act as water reducing agent and retardant.
- d. Water: Water shall be potable, fresh, clean and free of sewage, oil, acid, alkali, salts or organic matter.
- e. Fine Aggregate: Sand shall meet the requirements of current ASTM standards, designation C 33.

### 2. **Grout Mixes:**

The concrete/grout mix shall consist of Portland cement, sand, and water, and may also contain a mineral admixture and approved fluidifier. The components shall be proportioned and mixed to produce a concrete capable of maintaining the solids in suspension, which may be pumped without difficulty. These materials shall be proportioned to produce a hardened concrete/grout which will achieve the design strength within 28 days. The design 28-day concrete strength for this project shall be 2500 psi.

All materials shall be accurately measured by volume or weight as they are fed to the mixer. Time of mixing shall be not less than one minute at the site. If agitated continuously, the concrete/grout may be held in the mixer or agitator for a period not exceeding two and one half hours at concrete temperatures below 70 degrees F and for a period not exceeding two hours at higher temperatures, not exceeding 100 degrees F. Concrete/grout shall not be placed when its temperature exceeds 100 degrees F.

Protect concrete/grout from physical damage or reduced strength which could be caused by frost, freezing actions or low temperatures or from damage during high temperatures in accordance with ACI 305/306.

The concrete/grout mix shall be tested by making a minimum of six 2-inch cubes for each day during which compaction grouting is performed. A set of six cubes shall consist of two cubes to be tested at seven days, and two cubes to be tested at 28 days and two cubes held in reserve. Test cubes shall be cured and tested in accordance with ASTM C 109. Test the flow of each batch of concrete mix.

### 3. **Concrete/Grout Testing:**

- a. Sampling: Concrete/grout for the columns shall be sampled in accordance with ACI standards.
- b. Workability: The workability of concrete/grout shall be determined by the slump test as described in ACI standards or by an alternative approved method.
- c. Cube Tests: For each mix design of concrete, six cubes shall be made from a single batch when required for 65 cy of concrete/grout or part thereof in each day's work. Testing shall be carried out by an independent and approved laboratory. Two cubes shall be tested at an age of 7 days, two at 28 days, and two cubes shall be held in reserve for further testing, if required. Alternatively, cubes may be tested in accordance with an

## EXHIBIT 5 – SPECIAL PROVISIONS AND CONTRACT REQUIREMENTS

approved accelerated testing regime. The Contractor shall submit certified copies of the results of all tests to the Engineer.

- d. Standard of Acceptance: The standard of acceptance of the concrete mix cubes shall be in accordance with ACI standards or as otherwise approved.
- e. Record of Tests: The contractor shall keep a detailed record of the results of all tests on concrete/grout and concrete materials. Each test shall be clearly identified with the columns to which it relates.

### 4. **Batching Concrete/Grout:**

- a. General: Facilities shall be provided for the Engineer to inspect the concrete/grout mixing plant or plants when requested. Unless otherwise specified the requirements in Clauses 2.5.2, 2.5.3, 2.5.4 shall be met.
- b. Accuracy of Weighing and Measuring Equipment: The weighing and water-dispensing mechanisms shall be maintained at all times to within the limits of accuracy described in ACI standards.
- c. Tolerance in Weights: The weights of the quantities of each size of aggregate and of cement shall be within 2% of the respective weights per batch after due allowance has been made for the presence of free water in the aggregates, which shall be determined by the Contractor by an approved method.
- d. Moisture Content of Aggregates: The moisture content of aggregates shall be measured immediately before mixing and as frequently thereafter as is necessary to maintain consistency of mix.

### 5. **Mixing Concrete/Grout**

- a. Type of Mixer: The mixer shall be of the batch type, specifically designed for concrete/grout mixing.
- b. Tolerance of Mixer Blades: The mixing blades of pan mixers shall be maintained within the tolerances specified by the manufacturers of the mixers, and the blades shall be replaced when it is no longer possible to maintain the tolerances by adjustment.
- c. Cleaning of Mixers: Mixers which have been out of use for more than 30 minutes shall be thoroughly cleaned between the mixing of different types of cement.
- d. Minimum Temperature: The temperature of fresh concrete/grout shall not be allowed to fall below 37° F. No frozen material or materials containing ice shall be used. Newly cast columns are to be covered to protect them against freezing unless the final cut off level is at least 0.8 ft. below the final head level as cast. Where a column is cast in frozen ground, appropriate precautions shall be taken to protect any section of the column in contact with the frozen soil where this occurs below the cut off level.

### 6. **Transporting Concrete/Grout**

- a. Method of Transporting: The method of transporting concrete/grout shall be submitted for approval. Concrete/grout shall be transported in uncontaminated watertight containers in such a manner that loss of material and segregation are prevented.
- b. Pumping Concrete/Grout: Pumped concrete/grout complying with this Specification may be used. The methods employed in its use shall be subject to approval.

### 7. **Ready-mixed Concrete/Grout**

- a. Conditions of Use: Subject to approval, the Contractor may use ready-mixed concrete/grout in accordance with ACI standards. Approval shall be obtained for each proposed use of ready-mixed concrete/grout in different sections of the Works and for each different mix, which shall comply with this Specification.
- b. Mixing Plant: Unless otherwise agreed by the Engineer, truck mixer units and their mixing and discharge performance shall comply with the requirements of ACI standards.



**C. EXECUTION**

**1. General**

The Compaction grout column technology employs a drill stem for both penetration and maintaining borehole stability. The concrete/grout is pumped into the column from the base of the drill stem. All materials and work shall be in accordance with Sections A, B and C of this Specification.

**2. Layout**

The procedure for layout of columns and checking their positions shall be approved by the Engineer. The actual compaction grout columns shall be installed within 3 inches of the design location shown on the Drawings, approved shop drawings or as otherwise directed by the Engineer.

**3. Diameter of Columns**

The diameter of a column shall be not less than 24-in.

**4. Equipment**

The contractor shall use a drill rig capable of penetrating all necessary soil layers or obstructions.

**5. Penetration**

- a. Penetration Near Recently Cast Columns: Columns shall not be advanced so close to other columns which have recently been cast and which contain workable or unset concrete/grout that a flow of concrete could be induced from or damage caused to any of the columns. A minimum distance of 8 ft (center-to-center) shall be kept between columns less than 24-hours old and on-going column installations.
- b. Removal of Drill Pipe from the Ground: Drill Pipe shall not be extracted from the ground during the penetration or construction of a column in such a way that an open unsupported void or inflow of water into the column section would result.
- c. Depth of Columns: Any failure of a column to reach the required depth, as given in the Specification or shown on the Drawings, shall be reported to the Engineer without delay and a full statement of the reasons given.

**6. Placing of Concrete/Grout**

- a. Mix Design and Workability: Where not otherwise stated in this Section, the concrete shall comply with Section B of this Specification. The design and workability of concrete to be used in the formation of a column shall produce a mix which is suitable for pumping. It shall have a target slump of 4 to 6 inches unless otherwise approved and a minimum cement content of 580 lbs/yd<sup>3</sup>. The fine aggregate shall be in accordance with ACI standards. This mix shall be designed so that segregation does not occur during the placing process, and bleeding of the mix shall be minimized.
- b. Equipment for Supply of Concrete/Grout to Columns: Concrete/Grout shall be supplied to the column through suitable tubing and hoses.
- c. Commencement of Concrete/Grout Supply to Each Column: The technique and equipment used to initiate and maintain the concrete flow shall be such that a column of the full specified cross-section is obtained from the maximum depth to the final cut off level.
- d. Rate of Supply of Concrete/Grout: The concrete/grout shall be supplied to the column at a sufficient rate during drill pipe withdrawal to ensure that a continuous monolithic shaft of the full specified cross-section is formed, free from debris or any segregated concrete/grout. The rate of withdrawal of the drill pipe and pressures of concrete/grout

**EXHIBIT 5 – SPECIAL PROVISIONS AND CONTRACT REQUIREMENTS**

shall be measured and recorded throughout the phase of vibrator withdrawal for each column. The Contractor shall submit proposals for his method of monitoring construction for approval prior to the commencement of the Works.

- e. Completion of Columns: If the concrete/grout placing in any column cannot be completed in the normal manner, then the column shall be re-penetrated before concrete/grout has hardened and shall be completely replaced.
- f. Casting Level of Column Head: Concrete shall be cast to the commencing surface level or slightly above unless otherwise specified
- g. Disposal of Contaminated Material: The Contractor is responsible for disposal of all excavated soil, excess water, and spoil generated during installation of the compaction grouting installation at no extra cost. Manifests necessary for waste disposal shall be executed by the Engineer.

**7. Cutting of Column Heads**

When cutting off and trimming columns to the specified cut off level, the Contractor shall take care to avoid shattering or otherwise damaging the rest of the column. Any laitance, or contaminated, cracked or defective concrete/grout shall be cut away and the column made good in an approved manner to provide a full and sound section up to the cut off level.

**8. Documentation:**

Any proposed change in the approved construction program, necessitated by a change in the subsurface conditions, shall be submitted in writing to the Engineer for approval.

A daily log shall be submitted to the Engineer by the Contractor to include hole number, start/finish time of treatment, depth of treatment, diameter of drill hole, description of soil penetrated, and volume of grout/concrete placed at depth in no more than 2-ft increments.

**D. CONSTRUCTION**

The compaction grout columns shall be constructed prior to bridge foundations. Positive site drainage shall be established prior to construction of compaction grouting. Contractor shall control all spoils generated during compaction grouting and prevent spoils from flowing offsite. Spoils generated by compaction grouting shall be disposed of properly and removed from the site by the Contractor. No additional compensation shall be made for handling spoil.

Compaction grouting columns shall be constructed to the lines and elevation shown on the plans, and in accordance with the Special Provisions.

Compaction grout columns shall extend from the existing ground surface to the elevations outlined in the plans. No payment will be made for compaction grout columns installed within areas that are later excavated. The contractor shall be responsible to construct compaction grout columns to the depths required, and shall use the methods necessary to penetrate to the required depth, including but not limited to drilling through stiff and dense layers that may be present, as well as obstructions from existing construction.

The compaction grout columns shall be installed to the minimum required Area Replacement Ratio. The required minimum area replacement ratio ( $A_r$ ) achieved at any depth by the compaction grouting shall be that which is equivalent to the diameter of the grout columns at the center-to-center (c-c) spacing shown in the plans and on a triangular pattern. The area replacement ratio shall be defined by the following relationships:

$$A_r = \frac{\text{Column Area}}{\text{Tributary Area}} \times 100\%$$

Tributary Area

Where: Column Area = Area of circle based on column diameter as defined below.

**EXHIBIT 5 – SPECIAL PROVISIONS AND CONTRACT REQUIREMENTS**

Tributary Area = 0.866 (Column Spacing) <sup>2</sup> for triangular spacing.

Acceptance of the constructed column will be based on the theoretical column diameter determined from the volume of concrete/grout installed.

The Contractor shall, at all times, protect structures, underground utilities and other construction from damage caused by grouting operations. Damaged material shall be replaced or repaired to the satisfaction of the Engineer at no additional cost to the Department.

**E. METHOD OF MEASUREMENT**

The bid item for compaction grouting shall include the delivery and placement of all concrete material necessary for compaction grout column construction. It shall also include disposal of all spoil (surface water, soil, etc.) in a manner acceptable to the Department of Health and Environmental Control and to the Engineer.

**F. BASIS OF PAYMENT**

The quantity of ground modification measured for payments shall be the actual length of the installed compaction grout columns acceptable to the Engineer. No payment will be made for ground modification beyond the limits required by the Contract Documents, unless such increases in the specified area are directed in writing by the Engineer.

The accepted quantity, measured as above, will be paid for at the contract unit price per linear foot for compaction grout columns constructed at the diameter specified in the plans, which price and payment shall be full compensation for furnishing, hauling, treating, compacting of materials, removal of spoils and for all labor, equipment, tools, maintenance, and incidentals necessary to complete this item of work.

Payment will be made under:

<b>Item No.</b>	<b>Pay Item</b>	<b>Pay Unit</b>
8990353	GROUND MODIFICATION–COMPACTION GROUTING COLUMNS	Linear ft

**(35) SECTION 205: GROUND MODIFICATION – VIBRO-STONE COLUMN (VIBRO-DISPL.):**

August 25, 2015

**A. DESCRIPTION**

This section presents vibro-displacement requirements for ground modification by stone column (SC) construction at both bridge approaches using the dry bottom feed method. This Special Provision details the technical and quality assurance requirements for furnishing all supervision, labor, material, equipment, and related services necessary to construct all soil improvements by vibro-displacement. The construction work includes subsurface soil improvement by vibro-displacement and delivery and placement of all backfill necessary in the improvement process. Soil improvement by vibro-displacement method shall be provided in the areas shown in the roadway plans and as required by this Special Provision. Ground modification is for mitigation of settlement due to consolidation, settlement due to liquefaction and embankment stability.

The Contractor or Sub-contractor performing the vibro-displacement construction shall be one who can provide a minimum 5 year experience record documenting 15 recent successful projects completed with specific application to these site conditions, ground modification technique, and soil improvement criteria. References asserting this documentation shall be provided upon request. The Contractor must have sufficient production capacity to produce the required work without causing delay to the project.

The Contractor shall layout, and measure the locations for vibro work. Vibro points may be surveyed in or located by measuring offsets from surveyed points (e.g., project stations) using a tape measure.

## EXHIBIT 5 – SPECIAL PROVISIONS AND CONTRACT REQUIREMENTS

The Contractor shall notify the Engineer 48 hours prior to commencement of the vibro operations.

The Contractor shall submit plans and shop drawings to the Engineer for review and approval at least 30 days prior to work beginning, indicating the sequence, spacing, location, and depth of the vibro points to achieve the criteria outlined in this specification and shown in the roadway plans. Any change in the predetermined vibro program necessitated by a change in the subsurface conditions shall be immediately reported and submitted to the Engineer. Upon completion of the work, the Contractor shall submit a drawing of as-built locations of the stone columns.

### **B. MATERIALS**

The backfill for vibro-displacement shall consist of hard, durable crushed gravel or crushed stone with a gradation consistent with #57 sized crushed aggregate (meeting ASTM C33 coarse aggregate requirements). Fossiliferous or soft limestone materials shall not be used.

The Contractor shall submit certifications and test reports that indicate the backfill materials meet specified requirements prior to commencing field work.

### **C. CONSTRUCTION METHODS**

Prior to commencing work, the Contractor shall examine the following: site conditions, drawings, records of existing utilities and other existing subsurface structures, and Geotechnical Reports, including soil boring logs. This data will be made available by the Engineer to help determine vibro-displacement installation conditions.

Data on indicated subsurface conditions is provided solely for convenience of the Contractor. It is expressly understood that the Department, Engineer, or the Engineer's sub-consultants will not be responsible for interpretations or conclusions drawn therefrom by the Contractor. The Department and Engineer expressly encourage the Contractor to perform soil test borings or other subsurface explorations to determine whether the Contractor's proposed ground modification method is capable of installing the specified vibro-displacement stone columns. If the Contractor needs additional test borings and other exploratory operations, they may be conducted at no additional cost to the Department.

The vibro-displacement stone columns shall be constructed prior to bridge foundations. Positive site drainage shall be established prior to construction of the vibro-displacement stone columns. Contractor shall control all spoils generated during vibro-displacement stone column construction and prevent spoils from flowing offsite. Spoils generated by vibro-displacement stone column construction shall be disposed of properly and removed from the site by the Contractor. No additional compensation shall be made for handling spoil.

Vibro-displacement stone columns shall be constructed at the locations shown on the project roadway plans and in accordance with this special provision.

If stone columns are installed through embankment fill that will be later excavated, #57 stone should be used to backfill the portion above the excavation limit. No payment will be made for stone columns installed within areas that are later excavated. The contractor shall be responsible to construct vibro-displacement stone columns to the depths required, and shall use the methods necessary to penetrate to the required depth, including but not limited to pre-augering through stiff and dense layers that may be present, as well as obstructions from existing construction.

The stone columns shall be installed to the minimum required Area Replacement Ratio. The required minimum area replacement ratio ( $A_r$ ) achieved at any depth by the vibro-displacement stone columns shall be that which is equivalent to the design diameter of the stone columns spaced at the design center-to-center (c-c) on a triangular pattern.

## EXHIBIT 5 – SPECIAL PROVISIONS AND CONTRACT REQUIREMENTS

The area replacement ratio shall be defined by the following relationships:

$$Ar = \text{Stone Column Area} \times 100\%$$

Tributary Area

Where: Stone Column Area = Area of circle based on column diameter as defined below.

$$\text{Tributary Area} = 0.866 (\text{Column Spacing})^2 \text{ for triangular spacing}$$

Acceptance of the constructed column will be based on the theoretical column diameter determined from the volume of backfill installed and an assumed relative density of compacted washed stone equal to 90%.

The Contractor shall, at all times, protect structures, underground utilities and other construction from damage caused by vibro operations. Damaged material shall be replaced or repaired to the satisfaction of the Engineer at no additional cost to the Department.

At no time during stone column installation will the use of water be allowed to flush soil cuttings from mitigated zone.

The Contractor shall:

1. Verify the location of existing underground utilities by excavation before starting vibro operations. If utility lines are to remain in place, provide protection from damage during vibro operations.
2. Consult the Engineer immediately for directions as to procedure if uncharted or incorrectly charted piping or other utilities are encountered during excavation or execution of work. Cooperate with Department and public or private utility companies in keeping their respective service and facilities in operation. Repair damaged utilities to satisfaction of utility Department at no additional cost to Department.
3. Ensure that existing utilities serving facilities occupied by Department or others are not interrupted, except when permitted in writing by Engineer and then only after temporary utility services have been provided.
4. To ensure that stone columns for vibro-displacement are not installed at locations designated for future structural piles, installation should only be conducted at the locations shown on the roadway plans.

A pre-job conference is required between Engineer and Contractor(s), to review special requirements for work. Conference shall be arranged by Contractor and shall be planned sufficiently in advance of work to allow required attendees adequate notice (one week minimum) to make arrangements to attend.

The Contractor shall use a down-hole vibrator capable of providing at least 160 horsepower and 20 tons of force.

Specific equipment and procedural specifications are left to the Contractor to achieve the specified criteria. However, the following general guidelines are identified:

1. After penetration to the treatment depth, the vibrator should be slowly retrieved in 12-inch to 18-inch increments to allow backfill placement.
2. The vibrator should be re-driven through each increment into a recently treated depth interval to observe amperage buildup or increase (or equivalent pressure increase for hydraulic vibrators).

## EXHIBIT 5 – SPECIAL PROVISIONS AND CONTRACT REQUIREMENTS

3. Amperage buildup and backfill quantities are contingent to the type of vibrator, type of backfill, in situ soil conditions, and Contractor's procedure. Discussion between the Engineer and Contractor shall be conducted prior to work regarding individual equipment capabilities and expectations.

### **D. QUALITY CONTROL**

Various production columns shall be evaluated by the Engineer on the basis of volume backfill installed per vibro point. Standard and/or Cone Penetration Testing (SPT and/or CPT) will also be performed by the Engineer to explore specific production columns. The test locations shall be determined by the Engineer once the plans and shop drawings have been received from the Contractor and reviewed, but will typically be as shown on the SC Testing Detail in the project plan sheets. The Contractor shall inform the Engineer 30 days prior to the installation of the first production column so that the field testing can be scheduled appropriately.

The Engineer reserves the right to perform tests and to prepare test reports on items stated below.

The Engineer will make continuous inspections of vibro operations to determine the following:

1. Proper depth of penetration is obtained
2. Volume of backfill material installed per vibro point
3. Theoretical column diameter

The Contractor shall furnish a complete log for each vibro point on the project, to include the following:

1. Column identification
2. Date of installation
3. Recording of probe number
4. Start/finish time of probe
5. Approximate backfill quantities
6. Diameter of column
7. Location of column
8. Existing ground surface elevation
9. Top and bottom elevation of each column

The acceptance criteria for the stone columns shall be the diameter and spacing to create the required minimum area replacement ratio.

### **E. MEASUREMENT AND PAYMENT**

The quantity of ground modification measured for payments shall be the actual length of the installed stone columns acceptable to the Engineer. No payment will be made for ground modification beyond the limits required by the Contract Documents, unless such increases in the specified area are ordered by the Engineer in writing.

The accepted quantity, measured as above, will be paid for at the contract unit price per linear foot for Ground Modification, which price and payment shall be full compensation for mobilization, demobilization, furnishing, hauling, treating, compacting of materials, removal of spoils, constructing working platform, pre-augering/obstructions and for all labor, equipment, tools, maintenance, and incidentals necessary to complete this item of work.

Payment will be made under:

**EXHIBIT 5 – SPECIAL PROVISIONS AND CONTRACT REQUIREMENTS**

Item No.	Pay Item	Pay Unit
2051112	GROUND MODIFICATION – VIBRO-STONE COLUMN	Linear feet

**(36) SECTION 305: MAINTENANCE STONE:**

Maintenance Stone used on this project shall conform to the gradation requirements of Section 305, or to the gradation specified for Aggregate No. CR-14 in the Standard Specifications.

**(37) SECTION 401: DRESSING OF SHOULDERS:**

Prior to the placement of asphalt mixtures on existing roadways, the contractor will be required to remove all vegetation adjacent to the edge of pavement which impedes the placement of the asphalt mixture to the specified width. The contractor shall also remove and dispose of all excess asphalt which is disturbed during minor grading for widening or during removal of debris or grass from existing surface during preparation of surface for new lift. After the asphalt mixture has been placed, the contractor shall blade the disturbed material to the extent that the shoulder is left in a neat and presentable condition. All excess material shall be removed from the project. No direct payment shall be made for this work; all costs are to be included in the price of other items of work.

**(38) SECTION 401: HOT MIXED ASPHALT (HMA) PAVEMENT:**

Subsection 401.4.4, Paragraph 2 of the Standard Specifications is amended such that the following will be deleted:

“Do not place HMA surface courses, including Surface Type E, during the months of December, January, and February, except with written permission of the DOC.”

If final HMA surface paving will be completed during the months of December, January, or February, it shall comply with the requirements outlined below. Complete all HMA surface paving as soon as possible after HMA paving through the intermediate course is complete, utilizing all days with weather conditions suitable for paving.

- A. Temperature Segregation will be closely monitored and documented for mix variability using a handheld infrared camera or similar device that can be attached to the paver (MOBA). The frequency should be a minimum of one thermal image shot every 30 minutes (this may be reduced if the RCE deems the number of shots excessive). Thermal image shots should be taken directly behind the paver screed prior to beginning breakdown rolling. This information must be routinely turned in to the RCE along with the plant tickets and the asphalt plant reports.
- B. Application of tack coat will adhere to 401.4.18 of the 2007 Standard Specifications. Additionally, use a rapid or non-tracking tack to reduce excessive waiting time prior to paving.
- C. All trucks will be tarped and strapped to minimize heat loss, regardless of hauling distance.
- D. Contractor will provide an individual for checking mix temperatures in the haul trucks. All mix temperatures will be measured and recorded on the plant tickets by the contractor for every load delivered. SCDOT and Contractor ART will monitor the delivery temperatures to ensure specification compliance.
- E. Ensure existing surface temperatures meet the ambient air temperature requirements of Section 401.4.4.

**(39) SECTION 401: HOT MIX ASPHALT (HMA) QUALITY ASSURANCE:**

Reference is made to the Supplemental Technical Specification “Hot Mix Asphalt (HMA) Quality Assurance.” For the purposes of applying this Supplemental Technical Specification, there will be no pay factor adjustment greater than 100% for any given lot. When applying pay factor adjustments of less than 100%, a unit price of \$75 per ton will be used.

**(40) SECTION 401: HOT-MIX ASPHALT RIDEABILITY:**

Reference is made to the Supplemental Technical Specification “Hot-Mix Asphalt Rideability.” For the purposes of applying this Supplemental Technical Specification, there will be no pay factor

**EXHIBIT 5 – SPECIAL PROVISIONS AND CONTRACT REQUIREMENTS**

adjustment greater than 100%. When applying pay factor adjustments of less than 100%, price Adjustments will be calculated based on \$75 per ton.

**(41) SECTION 401: ASPHALT BINDER ADJUSTMENT INDEX:**

The Liquid Asphalt Binder Adjustment Index Supplemental Specification dated March 3, 2009 applies to this project. For this project the Basic Bituminous Material Index will be determined on the first calendar day of the month in which this project is let. The index and adjustment table will be available on the internet at <http://www.scdot.org/doing/construction/letting/MonthlyIndex.aspx>, or may be obtained from the office of the Contracts' Administrator.

The following is hereby included in the table entitled "Items of Work Eligible for A.C. Binder Adjustments" in the supplemental specification.

PREVENTATIVE MAINTENANCE SURFACE TREATMENT	SY	0.0026
ASPH. SURF. TREAT. (TRIPLE T-1)	SY	0.0024

All items of work included in this project, that are listed in the table entitled "Items of Work Eligible for A.C. Binder Adjustments" below paragraph 4 of the supplemental specification will be subject to price adjustment.

The following Section of the Supplemental Specification is hereby modified:

**Additional Provisions:**

The Department will calculate and apply fuel adjustments to estimates based on index values set at the beginning of the estimate period.

Estimate period begins on the 1st of the month and ends on the last day of the month. The 1st of the month Index will be compared to the contract Base Index to determine index adjustments for the estimate period.

**(42) SECTION 401: SURFACE PLANING OF ASPHALT PAVEMENT:**

**A. GENERAL**

**1. Description:**

This Special Provision replaces all references to Surface Planing of Asphalt Pavement in Subsection 401 of the Standard Specifications in their entirety. It does not replace or amend Subsection 611 of the Standard Specifications. It describes the material and construction requirements for the surfacing planing of existing asphaltic concrete pavement by micro-milling to remove wheel ruts and other surface irregularities, restore proper grade and/or transverse slope of pavement as indicated in the Plans or as instructed by the RCE. Ensure that the planed surface provides a texture suitable for use as a temporary riding surface or an overlay with OGFC with no further treatment or overlays. Do not use the planed surface as a temporary riding surface for more than ten days if no corrective action is required and no more than 21 days if corrective action is required unless otherwise instructed by the RCE.

**2. Pay Factor Adjustments**

When applying pay factor adjustments for surface planing discussed in Sections E.2 below a unit price of \$2.00 per square yard shall be used. For the purposes of applying the table in SC-M-502 Supplemental Technical Specification referenced in this special provision, there will be no pay factor adjustment greater than 100%.

**B. REFERENCED DOCUMENTS**



## EXHIBIT 5 – SPECIAL PROVISIONS AND CONTRACT REQUIREMENTS

1. SCDOT Standard Specifications, Edition of 2007
2. SC-M-502, Rideability of PCC Pavement

### C. EQUIPMENT

1. Provide power-driven, self-propelled micro-milling equipment that is the size and shape that allows traffic to pass safely through areas adjacent to the work. Also, use equipment with the following characteristics.
  - a. Ensure that the equipment is equipped with a cutting mandrel with carbide-tipped cutting teeth designed for micro-milling HMA and bituminous treated pavement to close tolerances.
  - b. Ensure that the equipment is equipped with grade and slope controls operating from a string line or ski and based on mechanical or sonic operation.
  - c. Ensure that the equipment is capable of removing pavement to an accuracy of 0.0625 inches.
  - d. Ensure that the equipment is furnished with a lighting system for night work, as necessary.
  - e. Ensure that the equipment is provided with conveyors capable of transferring the milled material from the roadway to a truck located to the side, rear, or front while minimizing airborne dust and debris.

### D. CONSTRUCTION REQUIREMENTS

1. Follow the Plans to micro-mill the designated areas and depths, including bridge decks, shoulder, and ramps, as required. Ensure that the following requirements are met.
  - a. Prior to commencement of the Work, construct a test section that is 1156 feet in length with a uniformly textured surface and cross section on the road to be treated as approved by the RCE. Ensure that the final pavement surface has a transverse pattern of 0.2 inches center to center of each strike area and the difference between the ridge and valley of the mat surface in the test section does not exceed 0.0625 inches.
  - b. Milling depth may range up to 2 inches as necessary to fully remove existing OGFC surface, which has a typical nominal depth of one inch, as well as lesser depths on shoulders to provide a planar surface that allows appropriate drainage prior to placement of new OGFC. While milling depths over one inch are anticipated to ensure OGFC removal in low spots as well as to meet rideability requirements, milling depth should be minimized when possible to avoid excessive removal of the pavement structure while still removing all existing OGFC.
  - c. The Department will test the test section for rideability following Subsection 6 of SC-M-502 for diamond ground and textured existing concrete pavement, except that the maximum acceptable rideability is 90 inches per mile for each 0.1 mile segment. The first and last 50 feet of the test section will not be included in the two 0.1 mile segments. Provide the RCE with at least three business days of notice prior to need of rideability testing.
2. If any of the requirements of Section D.1 are not met, do no further work and provide a written plan of action to the RCE detailing what steps will be taken to improve operations. The RCE may require corrective action to the test section prior to acceptance or accept the test section as is. Once the plan has been approved by the RCE, construct a second test section at a different location from the first. If the second test section meets the requirements of Section D.1 and is approved by the RCE, continuous milling may commence. If the second test section fails to meet the requirements of Section D.1, continue to construct test 1156 foot sections until satisfactory results are achieved.
3. Once continuous operations commence, continue to produce a uniform finished surface and maintain a constant cross slope between extremities in each lane.

**EXHIBIT 5 – SPECIAL PROVISIONS AND CONTRACT REQUIREMENTS**

4. Provide positive drainage to prevent water accumulation on the micro-milled pavement as shown on the Plans or as directed by the RCE.
5. Bevel back the longitudinal vertical edges greater than one inch that are produced by the removal process and left exposed to traffic. Bevel back at least 1.5 inches for each one inch of material removed. Use an attached mold board or other approved method.
6. When removing material at ramp areas and ends of milled sections, the transverse edges may be temporarily tapered 10 feet to avoid creating a traffic hazard and to produce a smooth surface. However, ensure that a neat transverse joint is created prior to the placement of the OGFC; do not terminate OGFC by “pinching” the OGFC over a tapered area.
7. Remove dust, residue, and loose milled material from the micro-milled surface. Do not allow traffic on the milled surface and do not place overlying layers on the milled surface until removal is complete.

**E. ACCEPTANCE**

1. Ensure that the micro-milling operation produces a uniform pavement texture that is true to line, grade, and cross section.
2. The Department will test and accept the milled surface for rideability as given in Subsections 6.2 through 6.4 of SC-M-502. The Adjusted Schedule of Payment given in Table 2 of Subsection 6 of SC-M-502 will apply to the contract unit price for the micro-milling as given in Subsection F of this special provision.
3. Micro-milled pavement surfaces are also subject to visual and straightedge inspections. Keep a 10-foot straightedge near the micro-milling operation to measure surface irregularities of the milled surface. Repair any areas exceeding 0.125 inches between the ridge and valley of the mat surface to the satisfaction of the RCE at no additional cost to the Department. Provide a written plan of action to the RCE for approval prior to performing any corrective action on the basis of rideability, grade, or surface texture.

**F. MEASUREMENT AND PAYMENT**

1. Measurement: The quantity measured for payment under this special provision is the number of square yards of micro-milled surface in place and accepted.
2. Basis of Payment: The quantity, as measured above, will be paid for at the contract unit price subject to the adjustments given herein, for which price and payment is full compensation for furnishing all materials, equipment, tools, labor, hauling, stockpiling, temporary asphalt, and any other incidentals necessary to satisfactorily complete the work. All reclaimed asphaltic pavement (RAP) becomes the property of the Contractor unless otherwise specified. No adjustment in the unit price for this item or other items will be considered for variations in the amount of RAP actually recovered.

Payment includes all direct and indirect costs and expenses required to complete the work. Payment will be made under:

Item No.	Pay Item	Unit
4013099	SURFACE PLANE ASPHALT PAVEMENT, VARIABLE	Square Yard

**(43) SECTION 401: FULL DEPTH ASPHALT PAVEMENT PATCHING:**

**A. DESCRIPTION:**

The Contractor shall patch existing asphalt pavement at locations of high severity fatigue cracking and failed patches as directed by SCDOT. This work shall consist of the removal of deteriorated pavement and replacing with a 6 inch full depth asphalt plant mix patch.

**B. CONSTRUCTION PROCESS:**

The deteriorated pavement shall be removed to the width and length indicated by the RCE, with the face of the cut being straight and vertical. The pavement shall be removed to a depth of six

(6) inches as directed by the RCE. In the event unstable material is encountered at this point, then such additional material shall be removed as directed by the RCE.

The volume of material removed below the patch shall be backfilled with crushed stone and thoroughly compacted in 4-inch layers with vibratory compactors. Prior to placing the asphalt patch material in the hole, the sides of the existing asphalt pavement shall be thoroughly tacked. The patch material shall then be placed in layers not exceeding 3 inches with each layer being thoroughly compacted with a vibratory compactor and pneumatic roller. The patch material shall be an approved SCDOT Asphalt Concrete Binder Course Mix. Patches shall be opened and filled in the same day. Asphalt mixture shall not be applied when the existing surface is wet or frozen. The finished patch shall be smooth riding. The patches are to be no less than six feet by six feet in size and should be spaced at not less than 25 feet between patches.

The quantity of full depth asphalt pavement patching to be paid for will be the actual number of square yards of existing asphalt pavement which has been patched and accepted. The work includes cleaning, removing, and disposing of debris from the patching work, furnishing and placement of crushed stone and asphalt patching material, and all other materials, labor, equipment, tools, supplies, transportation, and incidentals necessary to fulfill the requirements of this item of work.

The Contractor's bid shall include 1000 square yards of 6 inch full depth asphalt pavement patching. If more than the estimated square yards of patching are required by SCDOT, the Contractor will be paid a unit price of \$45.00 per square yard. If less than the estimated square yards of patching are required by SCDOT, the Contractor shall reimburse SCDOT for the quantity of full depth patching that was not needed. Reimbursement will be paid to SCDOT at a unit price of \$45.00 per square yard.

**(44) SECTION 403: PAVING UNDER GUARDRAIL:**

August 17, 2011

Section 403 is expanded as follows:

**A. GENERAL**

Provide paving under guardrail as shown in the plans, in accordance with plan details and these special provisions. Pavement under guardrail shall only be placed where shown in the plans or as directed by the Engineer.

**B. MATERIALS**

Pavement material under guardrail shall be the same as the hot mix asphaltic concrete surfacing being used on the adjacent roadway. Liquid asphalt binder shall be the same as that used for paving on the adjacent roadway.

Low-density Flowable Fill with a maximum 28-day compressive strength of 120PSI shall be used to fill leave out areas.

**C. CONSTRUCTION**

Place hot mix asphaltic concrete surfacing under guardrail in accordance with Section 401 of the Standard Specifications where indicated on the plans or as directed by the Engineer. Refer to details provided in this special provision for typical limits of paving and requirements for leave out areas around guardrail posts.

Pave area between the edge of pavement and the face of the guardrail when that distance is less than 20 feet.

**EXHIBIT 5 – SPECIAL PROVISIONS AND CONTRACT REQUIREMENTS**

Extend paving under guardrail to bridge end at locations where concrete approach slabs are used.

When at least one opening between parallel lines of guardrail is less than 20 feet wide, pave the entire area between the lines of guardrail.

When openings between parallel lines of guardrail are more than 20 feet wide, but obstructions such as bridge columns reduce the access between the guardrail and the obstruction to less than 20 feet and/or the distance between any two obstructions is less than 20 feet then the area with any single point of access less than 20 feet wide shall be paved.

When areas around obstructions are paved, no area should remain unpaved that will sustain plant life.

The top of pavement shall be constructed to be flush with surrounding earth shoulders and slopes.

Damage to pavement during subsequent construction, especially during driving of guardrail posts, should be minimized. Any damaged pavement must be restored to its original line and grade to the satisfaction of the Engineer.

Leave outs shown in the details shall be either formed or sawcut.

**D. MEASUREMENT AND PAYMENT**

Hot mix asphalt surface course shall be measured and paid for in accordance with Section 401 of the Standard Specifications.

Liquid asphalt binder shall be measured and paid for in accordance with Section 401 of the Standard Specifications.

When additional excavation is required to obtain the depth of pavement specified, this additional excavation will be measured separately and paid for by the cubic yard as unclassified excavation in accordance with section 203 of the Standard Specifications.

When borrow is needed to construct the area to be paved to meet the typical section, this borrow excavation will be measured and paid for separately as borrow excavation in accordance with section 203 of the Standard Specifications.

The costs to provide the leave outs shall be considered incidental to the hot mix asphalt surface course and no separate measurement or payment shall be made for providing leave out areas.

Flowable fill for leave out areas will be measured and paid for in accordance with section 210 of the Standard Specifications.

Payment under this section will include the following:

<b>Item No.</b>	<b>Pay Item</b>	<b>Unit</b>
2031000	UNCLASSIFIED EXCAVATION	CY
2033000	BORROW EXCAVATION	CY
2103000	FLOWABLE FILL	CY
40110XX	LIQUID ASPHALT BINDER PG__-22	TON
40303XX	HOT MIX ASPHALT CONCRETE SURFACE COURSE TYPE _	TON

EXHIBIT 5 – SPECIAL PROVISIONS AND CONTRACT REQUIREMENTS

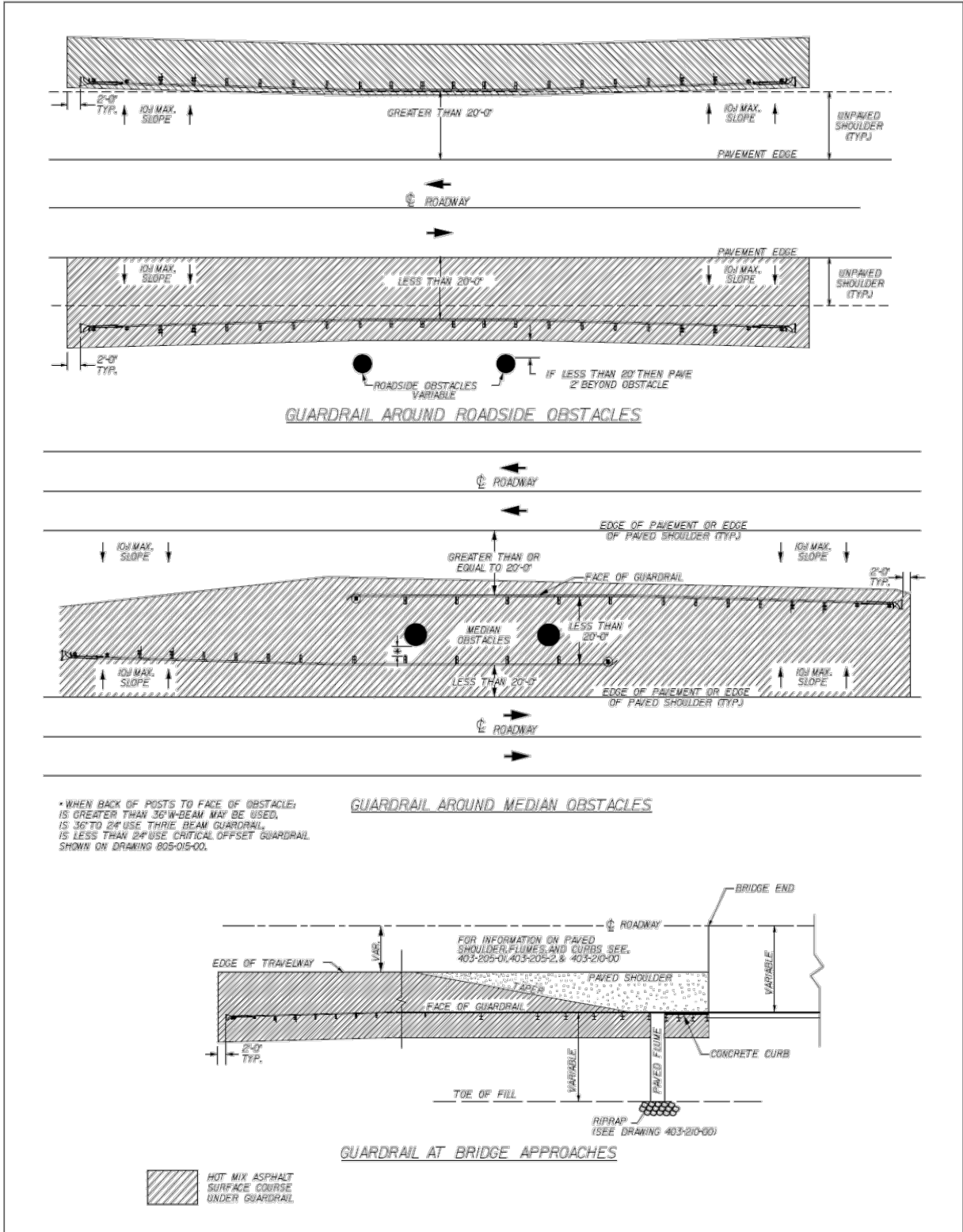
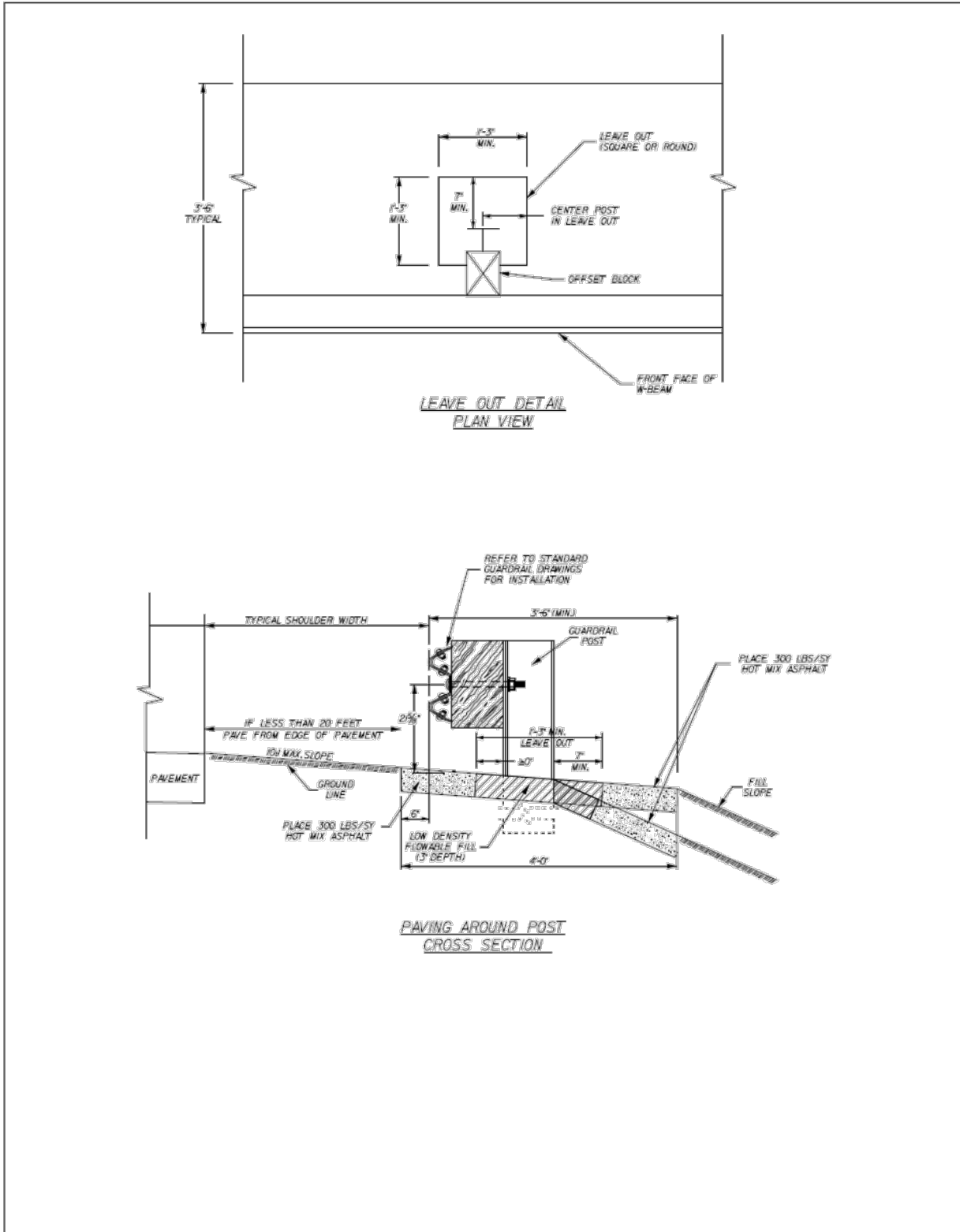

EXHIBIT 5 – SPECIAL PROVISIONS AND CONTRACT REQUIREMENTS



**(45) DIVISION 400 & 500: CROSS SLOPE VERIFICATION:**

August 26, 2015

Updated

**A. DESCRIPTION**

The cross slopes of the roadway are to be constructed as detailed in the plans and within the tolerances listed in this specification. It is the responsibility of the Contractor to ensure that the roadway cross slopes meet the requirements of the plans and this specification.

**B. RESPONSIBILITIES**

Carefully review the plans to determine the amount of information that has been provided by SCDOT prior to bidding. The following paragraphs explain the Contractor responsibilities based on the information contained in the plans.

1. SURVEY CONTROL:

The Contractor shall be responsible for establishing the survey control information. This information will include control points, horizontal alignment, and stationing. Surveys shall be in accordance with the SCDOT Pre-Construction Survey Manual (Latest Edition). <http://www.scdot.org/doing/survman.shtml>

2. SUPERELEVATION:

The Contractor shall be responsible for establishing the superelevation transition points with station reference at the following points along horizontal curves: begin and end of superelevation, flat cross slopes within superelevation transition, remove crown, begin and end of maximum superelevation, PC's, PT's, and cross slopes on begin and end of bridges. The Contractor shall establish superelevation in accordance with the SCDOT Highway Design Manual (Latest Edition).

3. EXISTING CROSS SLOPE DATA:

The Contractor shall be responsible for obtaining existing cross slope data.

4. SUBMITTALS:

The Contractor shall ensure that all deliverable documents are signed and sealed by a Professional Engineer qualified to practice in South Carolina. The Contractor and/or Professional Engineer shall give depositions and testify in court to the methodology, the accuracy of obtained cross slope, and that all criteria stated in this provision were met upon the request of the Department.

**C. CONTRACTOR PLANNING PROCESS**

1. INITIAL PAVEMENT DATA SURVEY:

The Contractor shall be responsible for collecting elevation data for the edge of each travel lane at even 100-foot stations in tangents and 50-foot stations in curves, begin and end of superelevation, flat cross slopes within superelevation transition, remove crown, begin and end of maximum superelevation, PC's, PT's, and cross slopes on begin and end of bridges. Record elevation data to the hundredth of a foot.

2. CALCULATING CROSS SLOPE:

The cross slope of a travel lane in the cross section view is the ratio or percent based on the change in horizontal compared to the change in vertical. Cross slope is calculated by subtracting the difference in elevation between the two edges of the travel lane and dividing this difference by the lane width. For example, a typical 48:1 Normal Crown (NC) pavement cross slope is calculated as  $-0.0208$  ft/ft or  $-2.08\%$  for a 12 foot lane (Figure 1). Figure 2

**EXHIBIT 5 – SPECIAL PROVISIONS AND CONTRACT REQUIREMENTS**

shows an example of a Remove Crown (RC) pavement cross slope which is calculated as +.0208 ft/ft or +2.08% for the 12 foot lane on the high side of superelevation.

**3. ACCEPTABLE TOLERANCES OF CROSS SLOPES:**

**Tolerance Level 1** for cross slopes shall be + 0.00174 ft/ft of the design cross slopes.

**Tolerance Level 2** for cross slopes shall be + 0.00348 ft/ft of the design cross slopes.

**4. INITIAL CORRECTIVE MEASURES PLAN:**

Submit to the RCE a summary of the Initial Pavement Data Survey. The data submitted for review shall include the following information for each travel lane:

Station	LETL Elevation	RETL Elevation	Lane Width	Calculated X-slope	Plan X- slope	Deviation	Tolerance Level
---------	-------------------	-------------------	---------------	-----------------------	------------------	-----------	--------------------

- a. Station
- b. Left Edge of Travel Lane Elevation (LETL) in ft
- c. Right Edge of Travel Lane Elevation (RETL) in ft
- d. Lane width in ft
- e. Calculated cross slope in ft/ft
- f. Plan cross slope in ft/ft
- g. Deviation between calculated cross slope and plan cross slope
- h. Tolerance Level (1, 2, or Out of tolerance)

The Contractor is required to prepare a plan to correct the cross slopes in the areas that are **outside of Tolerance Level 2**. The Contractor shall identify the areas that require corrective action. Submit an Initial Corrective Measures Plan to the Resident Construction Engineer for approval. The submittal will include the elevations, milling depths, and buildup thicknesses for HMA and areas of grinding and replacement for PCC for each edge of the travel lane and shoulder break points including the face of concrete barrier wall required to achieve the plan cross slopes and proper superelevation. The Contractor shall include an estimated quantity of corrective actions.

The RCE must approve the Initial Corrective Measures Plan prior to beginning corrective measures.

**D. CONSTRUCTION PROCESS**

**1. INITIAL CORRECTIVE MEASURES:**

For HMA pavement, perform all initial corrective measures prior to placing the first uniform overlay. For PCC pavement, corrective measures will be completed as a part of the application of a final surface texture. Follow the plan that was approved by the RCE.

**2. PROGRESS MEASUREMENTS:**

The Contractor shall verify cross slope measurements after the following work activities:

- a. Completion of initial corrective measures (milling and/or build-up for HMA, grinding and replacement for PCC)
- b. After each uniform lift of pavement prior to the final surface overlay (HMA)

Elevation data is to be collected at the edge of each travel lane perpendicular to the roadway centerline at the following locations:



**EXHIBIT 5 – SPECIAL PROVISIONS AND CONTRACT REQUIREMENTS**

- a. Minimum of one random location every 300 feet in tangent sections as determined by the Department
- b. Begin and end of superelevation, flat cross slopes within superelevation transition, remove crown, begin and end of maximum superelevation, PC's, and PT's
- c. Cross slopes on begin and end of bridges

Submit to the RCE a summary of the progress measurements for information only. The data submitted for review shall include the following information for each travel lane in the shown format:

Station	LETL Elevation	RETL Elevation	Lane Width	Calculated X-slope	Plan X-slope	Deviation	Tolerance Level
---------	----------------	----------------	------------	--------------------	--------------	-----------	-----------------

- 1) Station
- 2) Left Edge of Travel Lane Elevation (LETL) in ft
- 3) Right Edge of Travel Lane Elevation (RETL) in ft
- 4) Lane width in ft
- 5) Calculated cross slope in ft/ft
- 6) Plan cross slope in ft/ft
- 7) Deviation between calculated cross slope and plan cross slope
- 8) Tolerance Level (1, 2, or Out of tolerance)

**3. CONSTRUCT UNIFORM LIFTS OF ASPHALT:**

Construct uniform lifts of asphalt in accordance with the plan typical sections. Continue to monitor the construction process by conducting a Progress Measurement after each uniform lift of asphalt prior to the final lift (excluding Open Graded Friction Course (OGFC) if specified). For information only, submit the results to the RCE for each lift. Areas outside of Tolerance Level 2 will require correction prior to placing subsequent uniform lifts.

**4. FINAL PAVEMENT MEASUREMENT:**

Calculate the pavement cross slopes after placing the final surface (prior to OGFC if specified). Verify that the correct cross slopes have been obtained. Elevation data is to be collected at the edge of each travel lane perpendicular to the roadway centerline at the following locations:

- a. Even 100-foot stations in tangent sections and even 50-foot stations in curves
- b. Begin and end of superelevation, flat cross slopes within superelevation transition, remove crown, begin and end of maximum superelevation, PC's, and PT's
- c. Cross slopes on begin and end of bridges

Submit to the RCE a summary of the final pavement measurements. The data submitted for review shall include the following information for each travel lane:

Station	LETL Elevation	RETL Elevation	Lane Width	Calculated X-slope	Plan X-slope	Deviation	Tolerance Level
---------	----------------	----------------	------------	--------------------	--------------	-----------	-----------------

- 1) Station
- 2) Left Edge of Travel Lane Elevation (LETL) in ft
- 3) Right Edge of Travel Lane Elevation (RETL) in ft
- 4) Lane width in ft
- 5) Calculated cross slope in ft/ft
- 6) Plan cross slope in ft/ft
- 7) Deviation between calculated cross slope and plan cross slope
- 8) Tolerance Level (1, 2, or Out of tolerance)

Areas outside of **Tolerance Level 1 and within Tolerance Level 2** will be subject to review by the RCE and the DCE. The DCE will either require corrective measures at the Contractor's expense, or will provide a memo of acceptance with a pay reduction.

Areas outside of **Tolerance Level 2** will be subject to review by the DCE and the Director of Construction. The Director of Construction will either require corrective measures at the Contractor's expense, or will provide a memo of acceptance with a pay reduction.

5. PERFORMANCE ADJUSTMENTS

For Final Pavement Measurements within **Tolerance Level 1**, no pay adjustment will be made.

For Final Pavement Measurements outside of **Tolerance Level 1**, the DCE will either require corrective measures at the Contractor's expense, or will provide a memo of acceptance with a pay reduction of \$200/100' for each travel lane over the length of the section. The section length(s) will be determined as follows:

The beginning of each section will be halfway between the first point outside Tolerance Level 1 and the previous (adjacent) point within full compliance. The end of each section will be halfway between the last point outside Tolerance Level 1 and the adjacent point which is within full compliance. The minimum section length will be 100 feet. This amount will be deducted from monies due for pavement mixes.

For Final Pavement Measurements outside of **Tolerance Level 2**, the DOC will either require corrective measures at the Contractor's expense, or will provide a memo of acceptance with a pay reduction of \$300/100' for each travel lane over the length of the section. (This pay reduction will be in addition to the \$200 pay reduction for being outside of Tolerance Level 1.) The section length(s) will be determined as follows:

The beginning of each section will be halfway between the first point outside Tolerance Level 2 and the previous (adjacent) point within Tolerance Level 2. The end of each section will be halfway between the last point outside Tolerance Level 2 and the adjacent point which is within Tolerance Level 2. The minimum section length will be 100 feet. This amount will be deducted from monies due for pavement mixes.

For PCC pavements if corrective actions are made, refer to SC-M-503 for determining Thickness Tolerances.

**E. AS-BUILT PLAN SHEETS AND ELECTRONIC DELIVERABLES**

After any Performance Adjustments have been settled, provide final pavement cross sections on full size (22" x 36") plans sheets and submit to the RCE for inclusion in the as- built plans. Include the final disposition of cross slopes outside of the specified tolerances (i.e. corrected survey data, memo of acceptance from DOC, etc).

The as-built construction plans should include the following:

1. Control points, horizontal alignment, and stationing used to construct the project
2. Superelevation with horizontal curve data
3. Cross sections at even 100-foot stations in tangents and 50-foot stations in curves
4. Cross sections at the begin and end of superelevation, flat cross slopes within superelevation transition, remove crown, begin and end of maximum superelevation, PC's, PT's, and cross slopes on begin and end of bridges
5. Corresponding electronic files on CD-ROM or DVD to include all files used to develop the survey for the project, all files used to verify the cross slopes for the project, superelevation calculations, and any Microstation CADD files that pertain to the cross sections

**F. METHOD OF MEASUREMENT**

**EXHIBIT 5 – SPECIAL PROVISIONS AND CONTRACT REQUIREMENTS**

1. Measurement will be made for Cross Slope Verification after the RCE has reviewed and approved the work, including all submittals. Measurement is one lump sum.
2. No measurement will be made for any items of work required to make corrections to the final pavement cross slopes as deemed necessary by the Department.

**G. BASIS OF PAYMENT**

1. Cross Slope Verification will include any costs for interpreting the data, electronic and hard copies of survey data for the Engineer, traffic control, and any and all, tools, labor, and equipment necessary to perform the cross slope verification. The RCE will approve payment based on the following schedule:

Approval of the Initial Corrective Measures Plan	40%
Submittal of Progress Measurement for First Uniform Lift	60%
Submittal of the Final Pavement Cross Slope Measurements	80%
Acceptance of the As-Built Plan Sheets and Electronic Data	100%

2. The bid item number and description is:

ITEM NUMBER	DESCRIPTION	UNIT
1055102	CROSS SLOPE VERIFICATION	LS

**(46) DIVISION 600: EVALUATION OF RETROREFLECTIVITY:**

Within 20 days of initial application, the Contractor shall arrange for an independent party to evaluate the retroreflectivity of the pavement markings using a mobile retroreflectometer utilizing 30 meter CEN geometry. All lines shall be measured in both directions. The independent party conducting the measurements shall furnish directly to the Department a report detailing the average of the readings over one mile segments for each type of long line (white edgeline, white lane lines, yellow edgelines) along the length of the project. Average measurements shall also be provided along each ramp. Interstate mile markers may be used for beginning and ending points, with the first and last segments in each direction being less than one mile in length. The initial minimum retroreflectivity values shall be as follows:

Retroreflectivity (mcd/lux/m<sup>2</sup>)

<u>White</u>	<u>Yellow</u>
450	350

A second evaluation shall take place within 20 days prior to the end of the 180 day observation period. The evaluation method shall be the same as described above. The 180 day minimum retroreflectivity values shall be as follows:

Retroreflectivity (mcd/lux/m<sup>2</sup>)

<u>White</u>	<u>Yellow</u>
400	300

All markings failing to meet the initial minimum retroreflectivity requirements by more than 50 mcd / lux / m<sup>2</sup> shall be replaced immediately at the Contractor's expense. All markings failing to meet initial requirements by less than 50 mcd / lux / m<sup>2</sup> may be reevaluated at the time of the 180 day evaluation unless the defect causing the lower readings is obvious to the Engineer.

**(47) DIVISION 600: MANUAL ON UNIFORM TRAFFIC CONTROL DEVICES:**

The Contractor is advised that all work involving design or installation of traffic control devices, including but not limited to signs, pavement markings, elements of work zone traffic control, signals, etc., shall be in compliance with the FHWA's Manual on Uniform Traffic Control Devices (MUTCD), latest edition. The latest edition is defined as the edition that the Traffic Engineering Division of

SCDOT recognizes as having been officially adopted (Engineering Directive, Memorandum 19) at the time the project is let, unless stated otherwise in the Special Provisions.

**(48) SECTION 601: PENALTY FOR VIOLATING LANE CLOSURE RESTRICTIONS:**

The Contractor is advised that the Lane Closure Restrictions outlined in the Traffic Control Special Provisions will be strictly enforced. Should lane closures remain in place or not be completely removed by the time specified in the Traffic Control Special Provisions, a penalty will be assessed at the rate of **\$2,500.00 (Two Thousand Five hundred Dollars)** for each 1/4 hour interval (or any portion thereof). Should lane closures remain in place or not be completely removed for a period of longer than one hour beyond the time specified by the Traffic Control Special Provisions the penalty will increase to **\$5,000.00 (Five Thousand Dollars)** for each 1/4 hour interval (or any portion thereof).

**(49) SECTION 605: PERMANENT CONSTRUCTION SIGNS:**

Utility locations must be performed prior to the placement of Permanent Construction Signs. State Law requires that the location of each sign be marked with a white line in the roadway or a stake in the shoulder. The locator company will mark 25 feet on either side of the location. The responsibility for marking the sign locations prior to the contractor calling PUPS for utility locate lies with the party responsible for lines and grades on the project. If Construction Lines and Grades is a pay item, then the Prime Contractor is responsible for marking the sign location. If this is not included, it is the Department's responsibility to mark the locations.

Prior to marking the sign location, care must be taken when marking the signs to ensure that there are no obstructions or other mitigating factors that will cause the sign to be moved outside of the 50 foot utility window. Any costs associated with staking out the sign locations are considered incidental to the cost of Permanent Construction Signs.

Requests for utility locates must be specific and isolated to the sign locations if no ground disturbing activities are occurring outside of the sign placement.

**(50) SECTION 610: WORK ZONE TRAFFIC CONTROL PROCEDURES:**

The first sentence of Section 610.3 of the 2007 Standard Specifications is hereby revised to:

"Ensure that background color of personal protective apparel is either fluorescent Yellow-Green or fluorescent Orange-Red, and meets ANSI Standard 107-2004 National Standard for High Visibility Apparel Class 2 (or Class 3 as necessary) Performance Criteria, or latest edition."

Note #12 of Standard Drawing 610-005-00 is hereby revised to:

"During nighttime flagging operations, flaggers shall wear a Safety Vest and Safety Pants meeting ANSI Standard 107-2004 National Standard for High Visibility Apparel Class 3 Performance Criteria, or Latest Edition, and a Hardhat. The color of the apparel background material shall be either fluorescent Yellow-Green or fluorescent Orange-Red."

**(51) SECTION 653: RETROREFLECTIVE SIGN POST PANELS:**

**Section 653 is hereby modified as follows:**

**A. 653.2 MATERIALS**

Add the following paragraph:

Use retroreflective sign post panels constructed of a nonmetallic composite or 3mm aluminum composite material approved by the SCDOT covered with a 3-inch wide type III sheeting. Use sheeting that meets the requirements of Section 651.2.3. Use approved panels included on the Approved Products List For Traffic Control Devices in Work Zones.

**EXHIBIT 5 – SPECIAL PROVISIONS AND CONTRACT REQUIREMENTS**

**B. 653.4.2 ERECTION**

Add the following paragraph:

Mount the panel for the full length of the post from the sign to within 6 inches above the edge of the roadway. Mount panel only on post specified in the plans or special provisions. Secure the panel to the post with a minimum of 3 5/16-inch bolts and a lock washer and flat washer between post and nut, or tamper-resistant and rust-resistant screws. Use bolts, washers and nuts meeting the requirements of section 651.2.2. Provide the sheeting in the color that matches the background color of the sign except that the color for the "Yield" and "Do Not Enter" signs shall be red. Install panels to both posts, if there are two posts supporting the sign.

**C. 653.5 MEASUREMENT**

Replace with the following:

**653.5 Measurement**

The quantity for the pay item U-Section Post for Sign Support – (2 or 3)P, U-Section Post for Sign Bracing –2P or retroreflective sign post panel is the length of U-section post used for sign support or bracing or panel and is measured to the nearest 1/100 of a linear foot (LF) of the required post or panel, complete and accepted.

**D. 653.6 PAYMENT**

Replace with the following:

**653.6 Payment**

Payment for the accepted quantity for U-Section Post for Sign Support – (2or 3)P, U-Section Post for Sign Bracing –2P or Retroreflective Sign Post Panel, measured in accordance with Subsection 653.5, is determined using the contract unit bid price for the applicable pay item, and the payment includes all direct and indirect cost and expenses necessary to complete the work.

Payment is full compensation for fabricating and erecting U-section posts or braces or panels as specified or directed and includes providing mounting hardware; removing and disposing of existing signs supports, braces, and mounting hardware removed or replaced; replacing or relocating supports or braces shown on the Plans or directed by the RCE; and all other materials, labor, equipment, tools, supplies, transportation, and incidentals necessary to fulfill the requirements of the pay item in accordance with the Plans, the Specifications, and other terms of the Contract.

Pay items under this section include the following:

<b>Item No.</b>	<b>Pay Item</b>	<b>Unit</b>
6531205	U-SECTION POST FOR SIGN SUPPORTS – 2P	LF
6531210	U-SECTION POST FOR SIGN SUPPORTS – 3P	LF
6531215	U-SECTION POST FOR SIGN BRACING – 2P	LF
6531500	REFLECTIVE SIGN POST PANELS	LF

**(52) DIVISION 700: ANTI-GRAFFITI COATING:**

July 27, 2015

**A. GENERAL**

The anti-graffiti coating system shall be applied to locations as described in Exhibit 4 and in accordance with this Specification. Anti-graffiti coatings intended for use under this Specification shall be of a composition capable of preventing the adhesion of and facilitating the removal of acrylic, polyurethane, and alkyd spray paint. Use a clear, non-sacrificial anti-graffiti coating for all applications.

**EXHIBIT 5 – SPECIAL PROVISIONS AND CONTRACT REQUIREMENTS**

**B. MATERIALS**

All anti-graffiti coatings must possess the physical and handling characteristics that are compatible with the requirements of this Specification. Anti-graffiti coating shall be manufactured by one of the approved manufacturers listed on the most recent Qualified Product List 7, titled “Qualified Spray-On/Brush-On Surface Coatings for Concrete Finish”. Contractor shall ensure that the anti-graffiti coating is compatible with the selected applied Finish Coating, if applicable.

Anti-graffiti coatings shall contain less than 5.0 lb/gal volatile organic compounds (VOC) as defined by 40 CFR Part 59, Subpart D. The manufacturer shall supply the following additional information:

1. Technical data sheet that includes installation instructions and graffiti removal instructions, including any solvents or other materials, as necessary. Graffiti removal must be accomplished with nonproprietary cleaners as defined in ASTM D 6578.
2. Certification that non-sacrificial anti-graffiti coating shall not blister, crack, check, chalk, delaminate, or exhibit a color change of more than 8 dE94 (or dE76) CIELAB units for a period of one year after installation.

Clear coating must contain a UV degradable color for inspection purposes. UV degradable color must dissipate in a reasonable time period to allow inspection but not detract from visual impact of the structure.

Additionally, submit a certification that the coating meets the following laboratory performance requirements:

<b>Additional Laboratory Performance and Tests</b>		
<b>Test</b>	<b>Method</b>	<b>Limits</b>
Graffiti Resistance	ASTM D 6578; Use identified marking materials; initial and re-cleanability; and after exposure initial and re-cleanability	Cleanability Level 1, 2, or 3
Fluid Resistance	ASTM D 1308; Paint thinner, gasoline	No blistering, discoloration, softening, or adhesion loss

**C. APPLICATION**

Apply an anti-graffiti coating or coating system in accordance with manufacturer’s product data sheet and as specified herein, when the ambient temperature is between 40° and 90°F, and the surface temperature is between 50° and 85°F and rising.

Ensure all concrete has cured a minimum of 30 days before applying anti-graffiti coating. Do not apply coating when precipitation is expected within 12 hours of the completion of application or the relative humidity is above 88%.

**D. PROTECTION OF ADJACENT SURFACES**

Consider wind direction, velocity and geographic location as having a major impact on all cleaning and anti-graffiti coating operations. Use all necessary precautions to prevent cleaning and anti-graffiti coating materials from being dispersed outside the work site. If conditions are such that material is dispersed to areas where vehicles or other property may be damaged, suspend operations until conditions improve and work can continue without affecting adjacent property.

Protect all surfaces not intended to be coated, which are adjacent to, or in close proximity to the surfaces to be coated, during the application of anti-graffiti coating. Clean surfaces that are to be coated, as per the manufacturer’s product data sheet.

**E. SURFACE PREPERATION**

**EXHIBIT 5 – SPECIAL PROVISIONS AND CONTRACT REQUIREMENTS**

Prior to applying any anti-graffiti coatings, prepare all surfaces to be coated in accordance with ASTM D 4261 or ASTM D 4258 and the manufacturer's product data sheet. When the anti-graffiti coating or coating system is to be applied over an existing coating, apply a test patch (minimum area of 4 square feet) in accordance with this Specification. Allow the test patch to cure a minimum of 7 days without any defects. No time extension will be granted as a result of this test requirement.

**F. BASE COAT**

Apply the base coat, if part of the system, as specified by the manufacturer. Unless otherwise specified by the manufacturer, ensure the cured base coat has a minimum dry film thickness of 4.0-8.0 mils.

**G. FINISH COAT**

When applicable, ensure the base coat surface is clean and cured to a dry hard state according to the manufacturer's instructions before applying the finish coat. Mix finish coat and apply in accordance with the manufacturer's instructions. Ensure the cured finish coat of the two coat system has a minimum dry film thickness of 2.5-5.0 mils. Apply as many coats as necessary to provide a finish coat which is a uniform continuous film over the entire surface, free of pinholes, runs, sags, or any other deficiencies. Finish coat shall be considered "non-sacrificial".

**H. CORRECTION OF DEFICIENCIES**

Remove all applied anti-graffiti coatings identified by the Engineer as damaged, defective, or otherwise not meeting these Specifications, in accordance with the manufacturer's recommendations. Prepare the surface and reapply the coating in accordance with the manufacturer's recommendations and as specified herein, at no additional cost to the Department.

**I. REMOVAL OF GRAFFITI BEFORE ACCEPTANCE**

Remove all graffiti from areas receiving anti-graffiti coating, at no additional cost to the Department. Ensure all federal, state, and local environmental regulations are met when removing graffiti. Removal shall be in accordance with manufacturer's recommendations.

**(53) SECTION 701: SAND LIGHTWEIGHT CONCRETE:**

Use sand lightweight concrete, where specified in the plans, complying with the requirements of this Special Provision.

Sand lightweight concrete is composed of portland cement, fine aggregate, lightweight coarse aggregate, water, and admixtures. Provide sand lightweight concrete that complies with the applicable requirements of Section 701 of the Standard Specifications and the additional requirements herein.

At least 35 days prior to the proposed use, submit for approval a mix design from a testing laboratory accredited by the AASHTO Accreditation Program. Provide a mix that obtains a 28-day design compressive strength equal to or greater than 4000 psi and satisfies the following design criteria:

TEST	TEST METHOD	REQUIREMENT
Max. Unit Weight, plastic, lbs/ft <sup>3</sup>	AASHTO T 121	120
Max. Unit Weight, dry, lbs/ft <sup>3</sup>	ASTM C567 using equilibrium (air dried) unit weight	115
Min. Relative Dynamic Modulus, (percent)	AASHTO T 161 Procedure A	80

When submitting the mix design, include the source of the aggregates, cement, and admixtures and the gradation, specific gravity, and fineness modulus (fine aggregate only) of the aggregates. Submit test results showing the mix design conforms to the criteria, including the 28 day compressive strength of a minimum of six cylinders. Provide a mix design that produces an average

**EXHIBIT 5 – SPECIAL PROVISIONS AND CONTRACT REQUIREMENTS**

compressive strength sufficient to ensure that a minimum strength of 4000 psi is achieved in the field.

Produce an additional mix in accordance with AASHTO M 195 to determine the drying shrinkage. The maximum drying shrinkage for this mix is 0.07%.

For lightweight coarse aggregate, use expanded shale or slate that meets the requirements of AASHTO M 195. Provide lightweight coarse aggregate that meets the gradation table below.

GRADATION OF LIGHTWEIGHT CONCRETE AGGREGATE	
Sieve Size	Passing Square Opening Sieves (Percent by Weight)
1"	100
3/4"	90-100
3/8"	10-50
No. 4	0-15

Determine the soundness in accordance with AASHTO T 104. Loss of more than 10% of the lightweight aggregate in five cycles of the accelerated soundness test using sodium sulfate is not permitted.

Ensure the lightweight aggregate will have a wear of not more than 40% when tested in accordance with AASHTO T 96.

Ensure that lightweight aggregate has an absorbed moisture content equal to the 24 hours absorption as determined by AASHTO T 84 or T 85 when it is proportioned and incorporated into the mix. Consult with the lightweight aggregate supplier regarding minimum absorption required for proper performance of aggregate in concrete mixtures.

Have a representative from the manufacturer of the lightweight aggregate attend and participate in the Pre-pour Conference and also provide technical assistance in the production of the lightweight concrete at the batch plant and/or site for the first day of lightweight concrete mixing and placement operations.

Do not use AASHTO T 152 to determine the air content. Determine air content in accordance with AASHTO T 196.

Determine the plastic density (unit weight) of lightweight concrete in accordance with AASHTO T 121. Perform density tests for acceptance of lightweight concrete after final corrections for entrained air and slump have been made. When a density test is made and the results of the test exceed the specified maximum, perform a check test immediately from the same load of concrete. If the average of the 2 test results exceeds the specified maximum density, the load is rejected.

The quantity for Sand Lightweight Concrete is the volume of specified concrete within the neat lines of the structure as shown on the Plans or as revised by the RCE and is measured by the cubic yard (CY) of concrete, complete, and accepted. Deductions are made for the volume of embedded items, except for reinforcing steel; however, no deduction is made for edge chamfers of 3/4 inch or smaller.

**(54) SECTION 701: NON-CONFORMING CONCRETE:**

For purposes of applying the reduced payment and below strength provisions of Subsection 701.2.12.4 of the Standard Specifications, a unit price of 850 dollars per cubic yard will be used for normal weight concrete and a unit price of 880 dollars per cubic yard will be used for sand lightweight concrete.



**(55) SECTION 711: PILE AND DRIVING EQUIPMENT DATA FORM:**

Pile and Driving Equipment Data Form is included in Attachment B.

**(56) SECTION 711: GALVANIZED STEEL H PILING AND SWAY BRACES:**

March 16, 1999

**A. GENERAL**

This Supplemental Specification covers the cleaning, hot dip shop galvanizing, field cleaning and field repair of galvanizing for new Steel H Bearing Piling and Steel Sway Bracing where required and detailed in the plans.

**B. SURFACE PREPARATION**

The coating applicator shall pre-clean the material to be galvanized in accordance with accepted methods to produce an acceptable surface for hot dip galvanizing.

**C. SHOP GALVANIZING**

Hot dip galvanizing of iron and structural steel shapes shall be produced utilizing lead free technology. Steel H Bearing Piling and Steel Sway Braces shall be hot dip galvanized in accordance with the latest ASTM A 123 Specification to provide a uniform minimum coating thickness of 3.5 mils (89  $\mu\text{m}$ ). Shop repair of coatings not meeting the above minimum thickness requirements will not be allowed.

Galvanizing practices and procedures shall protect against possible embrittlement of the steel as described in ASTM A143.

Inspection and testing of hot dip galvanized coatings shall be done under the requirements of ASTM A 123.

The coating applicator shall have available for inspection a quality assurance manual and shall submit an original and two copies of the coating applicator's notarized Certificate of Compliance that the hot dip galvanized coating meets or exceeds the specified requirements of ASTM A 123 as modified by this Specification.

Galvanized members shall be stored, protected, handled and loaded in accordance with industry standards to protect the coating.

**D. SHOP INSPECTION**

Inspection of galvanizing practices and procedures will be performed by the Department's Research and Materials Laboratory. As soon as the project has been awarded, the Contractor shall notify the Research and Materials Laboratory at (803) 737-6698, P. O. Box 191, Columbia, South Carolina 29202. The Contractor shall provide the name and address of the coating applicator so that the inspection arrangements can be made.

**E. FIELD REPAIR OF GALVANIZING**

Field repair of galvanized coatings may be used to repair damaged areas, weld areas at pile splices, weld areas at sway braces to piles or other areas of coating damage. All field repairs shall be made in accordance with ASTM A 780. The Engineer shall be the sole judge of damaged areas that require field repair of the galvanized coating.

When galvanized members are to be field welded the Contractor shall clean the area at the weld location for a distance sufficient to provide an area free of coating for the weld metal to be deposited. The Contractor's cleaning method shall be pre-approved by the Engineer and cleaned areas shall be inspected and approved prior to field welding.

**F. METHOD OF MEASUREMENT**

## EXHIBIT 5 – SPECIAL PROVISIONS AND CONTRACT REQUIREMENTS

The galvanizing of Steel H Bearing Piling and Sway Braces will not be measured for payment. All cost for galvanizing shall be included in the price bid for the item galvanized.

### G. BASIS OF PAYMENT

All costs for labor, materials, equipment, tools and other incidentals required to galvanize the Steel H Bearing Piling and Sway Braces shall be included in the price bid for those items. No separate payment will be made for galvanizing.

### (57) SECTION 712: DRILLED SHAFT FORMS:

Drilled Shaft Forms are included in Attachment B.

### (58) SECTION 714: SMOOTH WALL PIPE:

#### A. REFERENCE

**SCDOT Supplemental Technical Specification SC-M-714**

#### B. DESCRIPTION

When bid items for smooth wall pipe are listed in the EBS file and/or proposal, the SCDOT will allow the use of reinforced concrete pipe, spiral ribbed aluminum pipe or high density polyethylene pipe in accordance with the specifications found in SC-M-714 (latest edition), the Standard Drawings, and this Special Provision. The plans may indicate reinforced concrete pipe only and are hereby superseded by this Special Provision.

#### C. MATERIALS

Smooth wall pipe is either Reinforced Concrete Pipe (RCP: 714-205-XX), Spiral Ribbed Aluminum Pipe (SRAP: 714-605-XX), or High Density Polyethylene pipe (HDPE: 714-705-XX) as described in SCDOT Supplemental Technical Specification SC-M-714 and in the SCDOT Standard Drawings. Use smooth wall pipe culvert from manufacturers listed on Qualified Product Lists 30, 68, or 69. No value engineering application is required in order to use alternate pipe.

For the following counties: Berkeley, Beaufort, Charleston, Colleton, Dorchester, Georgetown, Horry, and Jasper, provide pipe joints meeting AASHTO M 315 for RCP or passing the 13 psi pressure test as indicated on the QPL for SRAP or HDPE. Take care to properly lubricate and equalize pipe gaskets as indicated in the **SCDOT Standard Drawings** and **SC-M-714** to prevent gaskets from “rolling” during installation. For all other counties, provide pipe joints meeting AASHTO M 198, M 315, or passing the minimum 10 psi pressure test unless specific pipe joints are indicated in the plans or special provisions.

No other pipe type will be accepted as an alternate.

#### D. CONSTRUCTION REQUIREMENTS

Use only pipe that conforms to the minimum and maximum fill height limitations indicated on the appropriate standard drawing. Unless indicated otherwise in the plans, determine pipe fill height based on the following formula:

Fill Height = Elevation (top of curb or max grade above pipe) – Elevation (pipe crown)

For all locations where new pipe is being attached to an existing system, use one of the following options:

1. Any existing pipe may be extended using any acceptable alternate pipe type by using a drainage structure at the interface between the different pipe types. The drainage structure\* may consist of standard junction boxes, manholes, catch basins, drop inlets, or circular drainage structures detailed on **SCDOT Standard Drawings**. For larger diameter pipe, custom drainage structures may be required. Field cut existing pipe to remove damaged joint (if applicable) and install new drainage structure at the field cut interface. Always fully

## EXHIBIT 5 – SPECIAL PROVISIONS AND CONTRACT REQUIREMENTS

- clean existing pipe and pipe joints before installing joint sealant or gaskets and attaching new pipe.
2. For locations where existing pipe properties cannot be directly matched, use a custom designed interface\* (concrete collar, proprietary mastic wrap, custom coupling band, etc.) appropriate to interface the existing pipe to the new pipe of the same type. Submit interface drawings and design for review by the Engineer of Record and the Design Standards Engineer. Always fully clean existing pipe and pipe joints before installing joint sealant or gaskets and attaching new pipe. Replace existing pipe that has joint damage before connecting new pipe to the system.
  3. Any existing pipe may be extended using new pipe with the same joint profile and wall properties of the existing pipe. Always fully clean existing pipe and pipe joints before installing joint sealant or gaskets and attaching new pipe. Verify\* the following parameters before ordering new pipe:
    - a. For RCP to RCP, confirm wall thickness, joint profile shape, and compatibility with existing manufacturer's pipe. Replace existing pipe that has joint damage before connecting new pipe to the system.
    - b. For SRAP to SRAP, replace existing pipe that has joint damage before connecting new pipe to the system.
    - c. For HDPE to HDPE, confirm the manufacturer of the existing pipe and the joint compatibility with the new pipe. Provide a new gasket when connecting to existing spigot end of HDPE pipe. Replace existing pipe that has joint damage before connecting new pipe to the system.
    - d. For CAAP to CAAP, confirm the type and size of end corrugations of the pipe. When existing pipe has full helical corrugations, provide new connecting pipe with one end fully helical and fully helical coupling band. When end corrugation size does not match the corrugation size shown on SCDOT Standard Drawings, provide a drainage structure (described above) at the interface. Replace existing pipe that has joint damage before connecting new pipe to the system. Do not install CAAP as smooth wall pipe; however, use these requirements when plans specify installing new CAAP.

The **RCE** will verify that connections between existing pipe and new installed pipe have been handled with one of the options listed above. Repair or replace all existing to new joint interfaces that do not meet the requirements above at no additional cost to **SCDOT**.

In all installations, provide the RCE with a complete pipe table indicating the following: Plan Pay Item, Plan Pipe Description, Plan Quantity, Installed Pipe (diameter, type, class/gage), Installed Quantity, and description of interface used to join new pipe to existing pipe for each occurrence.

In cases where 2 or more different pipe types are installed, provide a copy of the proposed installation layout on the drainage/plan sheets to the RCE indicating which pipe is installed at each location.

### **E. MEASUREMENT**

Measure smooth wall pipe in accordance with methods specified in SC-M-714 for the pipe material installed.

\*No measurement will be made for drainage structure, designed interface, or field verification performed at each interface between existing pipe and new pipe unless drainage structure/interface is specified in the plans.

### **F. PAYMENT**

Payment will be made for smooth wall pipe regardless of the type of material installed. Payment for smooth wall pipe is as specified in SC-M-714 for the pipe material installed.

**EXHIBIT 5 – SPECIAL PROVISIONS AND CONTRACT REQUIREMENTS**

\*Include all costs for work related to connecting new pipe to existing pipe in the unit bid price of the new pipe. This connection work includes: drainage structure at the interface, custom designed interface, field verification of existing pipe and compatibility with new pipe, new gaskets, new joint sealant, new coupling bands, removal, and disposal of damaged sections of existing pipe.

ITEM NO.	DESCRIPTION	UNIT
7143XXX	X" SMOOTH WALL PIPE	LF
7143XXX	X"x X" SMOOTH WALL PIPE CUL.TEE	EA
714XXX	X" x X" SMOOTH WALL PIPE CUL.WYE	EA
7144XXX	X" SMOOTH WALL PIPE X DEG BEND	EA
7144XXX	SMOOTH WALL PIPE INCR.- X" TO X"	EA

**(59) SECTION 714: PIPE END TREATMENTS (2/5/2010):**

**A. REFERENCE**

SCDOT Supplemental Technical Specification SC-M-714

**B. DESCRIPTION**

For exposed pipe culvert ends, provide an end treatment in accordance with this special provision.

**C. MATERIALS**

Rigid pipe culvert is Reinforced Concrete Pipe (RCP: 714-205-00). Flexible pipe culvert is either Spiral Ribbed Aluminum Pipe (SRAP: 714-610-00), High Density Polyethylene pipe (HDPE: 714-705-00), or Corrugated Aluminum Alloy Pipe (CAAP: 714-605-00).

Use minimum Class B riprap for pipe up to 84" diameter. Use minimum Class C riprap for pipe 84" diameter or larger.

Use minimum Class 4000 concrete (4000P for precast).

Use ASTM A-706 grade 60, low-alloy steel deformed rebar.

Use minimum AASHTO M-196 Alclad 3004-H32 alloy aluminum.

Use Type M Mortar Grout unless specified otherwise.

**D. CONSTRUCTION REQUIREMENTS**

Use one of the following end treatments as specified in the plans or special provisions:



For all exposed crossline pipe ends, when an end treatment is not specified in the plans, use **Pipe Riprap Protection** (804-3xx-xx). For flexible pipe larger than 24" diameter, install pipe straight headwall, pipe end structure, flared end section, or wingwall section in addition to riprap. For all exposed driveway pipe ends where no end treatment is specified in the plans, use **Pipe Riprap Protection** (804-3xx-xx) unless directed otherwise by the engineer.

## EXHIBIT 5 – SPECIAL PROVISIONS AND CONTRACT REQUIREMENTS



Use **Beveling of Pipe End** (719-610-00) when specified in the plans or special provisions. Beveled ends may only be used on flexible pipe up to 24" diameter and on rigid pipe up to 60" diameter. When beveling of pipe ends is specified on flexible pipe larger than 24" diameter, install pipe straight headwall, pipe end structure, flared end section, or wingwall section. Use factory fabricated beveled ends for all pipe types unless approved by the Engineer.



Use **Pipe Straight Headwall** (719-605-00) when specified in the plans or special provisions. Use straight headwall only in locations where pipe exposed end does not face the direction of traffic.



Use **Pipe End Structure** (719-615-00) when specified in the plans or special provisions. Use pipe end structure in locations where pipe exposed end faces the direction of traffic. Pipe end structures may be used in other locations if approved by the RCE.

## EXHIBIT 5 – SPECIAL PROVISIONS AND CONTRACT REQUIREMENTS



Use **Pipe Flared End Section** when specified in the plans or special provisions.



Use **Pipe Wingwall Section** when specified in the plans or special provisions.

Completely seal interface between pipe and end treatment with grout. If bricks or shims are used to place pipe, take care to remove all air pockets and voids when grouting.

For systems not designed in the SCDOT Standard Drawings, provide shop drawings, installation procedure and design calculations for review by RCE. Design must include provision to control erosion around the structure and prevent the separation of the end treatment from the pipe system. Design must provide for a proper seal at all construction joints including the interface between the pipe and the structure. Design must be self-supporting and not induce any additional loads on the pipe. Submit designs for consideration as new standard drawings to the Design Standards Engineer at the address listed in the SCDOT Standard Drawings book.

### E. MEASUREMENT

Measure pipe in accordance with SC-M-714

Measure end treatments in accordance with Standard Specifications, Standard Drawings, or Special Provisions

### F. PAYMENT

Beveling of pipe ends will be in addition to the standard pipe pay item. Payment for the item Beveling of Pipe Ends includes all labor required to factory (or field, if approved) fabricate a bevel on one end of pipe.

Pipe culvert and end treatments, measured as provided in **SC-M-714 Subsection x.4**, are paid for at the contract unit price for the respective items, which price and payment is compensation for furnishing all material, labor, equipment, tools including hauling and placing all pipe sections and materials, excavation of the entire standard trench, bedding, and pipe backfill as described in the measurement section (both structural and embankment backfill in this region), removal of existing pipe to be replaced, constructing pipe joints, removal of old end treatments, cleaning out pipe, disposal of surplus materials, all visual inspection, and all incidentals necessary to complete the work.

**EXHIBIT 5 – SPECIAL PROVISIONS AND CONTRACT REQUIREMENTS**

Add the following paragraph to SC-M-714 subsections x.5:

Payment for riprap and geotextile for erosion control under riprap as measured in subsection x.4 includes all direct and indirect costs and expenses necessary to complete the work.

**(60) SECTION 719: CAST IN PLACE CONCRETE PIPE COLLAR:**

**A. DESCRIPTION**

A cast in place concrete pipe collar is used to provide a permanent connection between two pipe culverts of the same diameter but different joint profiles. Pipe collars can be used between two pipe of the same material or different material. Use only pipe that conforms to SC-M-714, Permanent Pipe Culverts.

**B. MATERIAL**

Use minimum class 4000 concrete.

Use reinforcement steel conforming to ASTM A706 Grade 60.

See SCDOT Standard Drawings or Project Plans for other material requirements and design details.

**C. CONSTRUCTION REQUIREMENTS - GENERAL**

Follow SCDOT Standard Drawings 719-705-xx for minimum dimensions and details. Use geotextile wrap on joint to minimize concrete intrusion into the joint during the forming and curing process.

**D. MEASUREMENT**

Measure concrete pipe collars by each location where pipe diameter of different joint profiles are to be connected. Include in measurement all materials and work to complete the pipe collar as shown in the Standard Drawings or plans.

**E. PAYMENT**

Payment will be made for each location.

ITEM NO.	DESCRIPTION	UNIT
7197051	CONCRETE COLLAR FOR UP TO 12" PIPE	EA
7197052	CONCRETE COLLAR FOR UP TO 24" PIPE	EA
7197053	CONCRETE COLLAR FOR UP TO 36" PIPE	EA
7197054	CONCRETE COLLAR FOR UP TO 48" PIPE	EA
7197054	CONCRETE COLLAR FOR UP TO 60" PIPE	EA
7197056	CONCRETE COLLAR FOR UP TO 72" PIPE	EA

**(61) SECTION 727: CROSSHOLE SONIC LOGGING OF DRILLED SHAFT FOUNDATIONS:**

Crosshole Sonic Logging (CSL) Testing is required for all drilled shafts. SCDOT shall be responsible for all CSL Testing.

**(62) DIVISION 800: GEOTEXTILE FOR DRAINAGE FILTRATION:**

October 15, 1991

**A. ACCEPTANCE**

The Contractor shall supply to the Resident Engineer, prior to placing the material, certified test results from a recognized laboratory of those tests specified herein. Acceptance will be based on the test results meeting these requirements<sup>1</sup> and the material meeting all stated specifications. The Resident Engineer shall submit the certified test results to the Research and Material Engineer for acceptance. Test data shall be no more than 1 year old at the time it is furnished to the Department. Once a fabric has been accepted, it will be listed on an Approval Sheet, and

**EXHIBIT 5 – SPECIAL PROVISIONS AND CONTRACT REQUIREMENTS**

only those materials listed will be acceptable. Test data must be resubmitted for reapproval every 2 years. No fabric will be used nor will payment be made for fabric until the fabric certification is received and approved by the Research and Materials Engineer. The Department reserves the right to sample and test any of the fabrics, or other materials used in drainage filtration, at any time.

**B. PIPING RESISTANCE (SOIL RETENTION - ALL APPLICATIONS)**

1. Soils with 50% or less particles by weight passing U.S. No. 200 sieve:

$$\text{EOS No. (fabric)} \geq 30 \text{ U.S. Std. Sieve No.}$$

2. Soils with more than 50% particles by weight passing U.S. No. 200 sieve:

$$\text{EOS No. (fabric)} \geq 50 \text{ U.S. Std. Sieve No.}$$

Note:

- a. Whenever possible, fabric with the lowest possible EOS No. should be specified.
- b. When the protected soil contains particles from 1 inch size to those passing the U.S. No. 200 sieve, use only the gradation of soil passing the U.S. No. 4 sieve in selecting the fabric.

**C. PERMEABILITY**

$k(\text{fabric}) \geq 10 k(\text{soil})^2$	$k(\text{Fabric}) \geq k(\text{soil})^2$
---	--

\*Woven monofilament fabrics only; percent open area  $\geq 4.0$  and EOS No.  $\leq 100$  sieve.

**D. CHEMICAL COMPOSITION REQUIREMENTS/CONSIDERATIONS**

- 1. Fibers used in the manufacture of civil engineering fabrics shall consist of long chain synthetic polymers, composed of at least 85% by weight of polyolefins, polyesters, or polyamides. These fabrics shall resist deterioration from ultraviolet exposure.
- 2. The engineering fabric shall be exposed to ultraviolet radiation (sunlight) for no more than 30 days total in the period of time following manufacture until the fabric is covered with soil, rock, concrete, etc.

**E. PHYSICAL PROPERTY REQUIREMENTS (ALL FABRICS)**



**EXHIBIT 5 – SPECIAL PROVISIONS AND CONTRACT REQUIREMENTS**

	Class 1 Fabric <sup>3</sup> Protected	Class 2 Fabric <sup>3</sup> Unprotected
Grab Strength (ASTM D-4632 or ASTM D-1682)	80 lbs.	180 lbs.
Seam Strength <sup>4</sup> (ASTM D-4632 or ASTM D-1682)	70 lbs.	160 lbs.
Puncture Strength (ASTM D-3787)	25 lbs.	80 lbs.
Burst Strength (ASTM D-3786)	130 psi.	290 psi.
Trapezoid Tear (ASTM D-4533)	25 lbs.	50 lbs.
Ultraviolet Degradation at 150 hours (ASTM D-4355)	70%	70%

<sup>1</sup> All numerical values represent minimum average roll values (i.e., any roll in a lot should meet or exceed the minimum values in the table). Use values for the weaker principal direction. Lots should be sampled according to ASTM D-4354.

<sup>2</sup> Permeability should be based on the actual fabric open area available for flow. For example, if 50% of the fabric area is to be covered by flat concrete blocks, the effective flow area is reduced by 50%.

<sup>3</sup> Fabric is said to be protected when used in drainage trenches or beneath/behind concrete (Portland or asphalt cement) slabs. All other conditions are said to be unprotected,

Examples of each condition are:

Protected: highway edge drains, blanket drains, smooth stable trenches < 10 feet in depth. In trenches, in which the aggregate is extra sharp, additional puncture resistance may be necessary.

Unprotected: stabilization trenches, interceptor drains on cut slopes, rocky or caving trenches or smooth stable trenches > 10 feet in depth.

<sup>4</sup> Values apply to both field and manufactured seams.

**(63) DIVISION 800: GEOCOMPOSITE WALL DRAIN:**

May 6, 2003

**A. DESCRIPTION**

A geocomposite wall drain is a prefabricated drain system that is used to provide drainage behind retaining walls. The geocomposite drain consists of a flexible plastic drainage core bonded to a non-woven geotextile. Geocomposite wall drains shall be placed continuously along the back of the wall as shown in the plans or as otherwise directed by the Engineer. The Contractor shall furnish all necessary labor, equipment, and materials and perform all operations necessary for the installation of geocomposite wall drains in accordance with the details shown on the plans and with the requirements of this specification.

**B. ACCEPTANCE CRITERIA**

**EXHIBIT 5 – SPECIAL PROVISIONS AND CONTRACT REQUIREMENTS**

The Contractor shall supply to the Engineer, prior to placing the material, certified test results of those tests specified herein from a recognized laboratory. Acceptance will be based on the test results meeting the geocomposite system properties, drainage core properties, and geotextile properties stated in this specification. The Engineer shall submit the certified test results to the Research and Material Engineer for acceptance. Test data shall be no more than one year old at the time it is furnished to the Department. Geocomposite wall drains shall not be installed until the material certification is received and approved by the Research and Materials Engineer. The Department reserves the right to sample and test any of the materials used in the geocomposite wall drain system.

Labeling, shipment, and storage of the geocomposite wall drain materials shall follow ASTM D 4837. Product labels shall clearly show the manufacturer or supplier name, style number, and roll number. Geocomposite rolls shall be wrapped with a material that will protect the geocomposite drain from damage due to shipment, water, sunlight, and contaminants. The protective wrapping shall be maintained during periods of shipment and storage.

**C. MATERIAL**

The geocomposite wall drain shall be prefabricated type made up of a lightweight, high impact polymeric drainage core bonded to the geotextile at intervals not exceeding 1.5 inches. The geocomposite wall drain shall be solid backed allowing drainage of water on only one side. The non-woven geotextile is thermal (heat) bonded or fungicide glue bonded to the polymeric drainage core. The geocomposite product sheets or rolls shall have a minimum width of 3 feet with a minimum coverage area of 40 square feet. A geotextile flap shall be provided along all drainage core edges. This flap shall be of sufficient width for sealing the geocomposite drain edge to prevent soil intrusion into the drainage core during and after installation. The geotextile shall cover the full length of the drainage core.

The wall drainage system shall meet the following geocomposite system properties in addition to the individual component properties of the polymeric drainage core and the non-woven geotextile. All numerical values listed in the required property tables shown below represent minimum average roll values (MARV) per ASTM D 4759 unless indicated otherwise. Values for the weaker principal direction should be used. Testing shall be performed in accordance with the methods referenced in this specification. Sampling of lots shall be in accordance with ASTM D 4354.

<b>GECOMPOSITE SYSTEM PROPERTIES</b>		
<b>TEST</b>	<b>METHOD</b>	<b>LIMIT</b>
Flow Capacity (gpm/ft. width) At a hydraulic gradient of 1.0 and a minimum normal stress of 3600 psf (Normal load maintained for 300 hours or until equilibrium)	ASTM D 4716	14

<b>DRAINAGE CORE PROPERTIES</b>		
<b>TEST</b>	<b>METHOD</b>	<b>LIMIT</b>
Thickness (inches)	ASTM D 1777	0.3 minimum / 0.5 maximum
Compressive Strength (psf) At 20% Deformation (10,000 hour minimum duration)	ASTM D 1621	14,000

**EXHIBIT 5 – SPECIAL PROVISIONS AND CONTRACT REQUIREMENTS**

<b>GEOTEXTILE PROPERTIES</b>		
<b>TEST</b>	<b>METHOD</b>	<b>LIMIT</b>
AOS (Equiv. U.S. Sieve)	ASTM D 4751	50 maximum average roll value
Permittivity (sec <sup>-1</sup> )	ASTM D 4991	1.0
Grab Tensile Strength (lbs.)	ASTM D 4632	80
Grab Tensile Elongation (%)	ASTM D 4632	50
Trapezoidal Tear Strength (lbs.)	ASTM D 4533	40
Puncture Strength (lbs.)	ASTM D 4833	50
Burst Strength (psi)	ASTM D 3786	150
Ultraviolet Stability (%) (Retained strength after 500 hours of exposure)	ASTM D 4355	70

**D. CONSTRUCTION REQUIREMENTS - GENERAL**

The Contractor shall check the geocomposite wall drain upon delivery to ensure that the proper material has been received. The geocomposite wall drain shall be protected during shipment and storage at the construction site from temperatures greater than 71 °C, mud, dirt, debris, and any other environmental condition that may damage the material's physical property values. The wall drainage system shall be protected from direct sunlight in accordance with the manufacturer's recommendations.

The geocomposite wall drain will be rejected at the time of installation if it has defects, tears, punctures, flaws, deterioration, or damage incurred during manufacture, shipment, or storage. Torn or punctured sections shall be removed or repaired as directed by the Engineer. Any geocomposite wall drain damaged during manufacture, shipment, or storage shall be replaced by the Contractor at no additional cost.

If at any time the Engineer determines that the method of installation does not produce a satisfactory wall drainage system, the Contractor shall alter his method and/or equipment as necessary to comply with this specification.

The geocomposite wall drain shall be installed in accordance with the plans and specifications. The surface that the geocomposite drain will be placed against shall be cleaned by removing all soil, debris, and irregularities that will prevent intimate contact between the surface and the geocomposite drain. The geocomposite wall drain shall be secured to the wall using metal stick clips, adhesives, or as recommended by the manufacturer. The geocomposite wall drain shall be installed so as to allow weepholes, as shown in the plans, to drain water from the drainage core and underdrain pipes.

All joints shall be formed by peeling or trimming the geotextile off the attached section to expose 3 inches of the drainage core. The drainage core of the second section being attached is then overlapped 2 inches over the first drainage core. The joint is then covered by reattaching the geotextile flap and securely fastening it to the lower geotextile by means of a continuous strip of 3 inch wide waterproof plastic tape. Each overlapping course shall be shingled in the direction of water flow. If joints cannot be formed by interlocking the cuspatations, then the drainage core should be butted together and covered with continuous, 6 inch wide geotextile. The geotextile fabric shall be centered over the joint and securely fastened to the two geocomposite drains with 3 inch wide waterproof plastic tape.

All exposed edges of the geocomposite wall drain shall be covered with geotextile by tucking and securing a minimum of 4 inches of geotextile behind the drainage core. This may be done by using the geotextile flaps at the edges or using a 12 inch wide continuous strip in the same manner, taping it to the exposed fabric 4 inches in from the edge with a continuous strip of 3 inch wide waterproof plastic tape, and folding the remaining geotextile and tucking it behind the drainage core edge.

## EXHIBIT 5 – SPECIAL PROVISIONS AND CONTRACT REQUIREMENTS

If the geotextile is torn, perforated, or ripped during installation, it shall be patched or replaced as directed by the Engineer. The damaged section shall be cut out and replaced completely or repaired by placing a piece of geotextile over the damaged area and providing a minimum of 4 inches of overlap on all sides over the damaged area and secured with 3 inch wide waterproof plastic tape. Damaged drainage core sections shall be discarded and replaced. Any geocomposite wall drain damaged during installation shall be replaced or repaired by the contractor at no additional cost.

The underdrain pipes and free draining aggregate shall be placed as shown in the plans or as directed by the Engineer. A positive outlet for the water in the geocomposite drain shall be maintained at all locations. Weepholes shall not be sealed or made ineffective by the wall drain material. This may involve making a hole in the drainage core at the weephole location. The geotextile drainage filtration fabric used to envelop the underdrain system shall be tucked 6 inches behind the geocomposite drain and overlapped over the geocomposite drain a distance of 12 inches and continuously secured with 3 inch wide waterproof plastic tape.

Backfill shall be placed immediately over the geocomposite wall drain. The contractor shall backfill against the wall in a manner that does not damage the geocomposite drainage system. Care shall be taken to avoid excessive settlement of the backfill material. The geocomposite wall drain shall not be exposed for more than seven days prior to backfilling. Any geocomposite drainage system component that is damaged during the backfilling operation shall be replaced or repaired as directed by the Engineer.

### **E. METHOD OF MEASUREMENT AND BASIS OF PAYMENT**

Geocomposite wall drains will not be measured for payment. The cost of the geocomposite wall drain shall be included in the cost of the retaining wall or wall system where the drainage system is being installed.

### **(64) SECTION 805: THREAD LOCKING GUARDRAIL HARDWARE:**

Use a permanent thread locking compound meeting Military Specification Mil-S-46163A Type I, Grade L. Follow the thread locking compound manufacturer's directions and apply compound to all the fasteners within Type T End Treatments, Impact Attenuators, and Crash Cushions. Apply compound to all guardrail fasteners across bridges or on base plate mounted posts, or in locations directed by the Resident Construction Engineer.

### **(65) SECTION 805: TL3 TYPE T TANGENT END TERMINALS:**

Qualified Product List 49 provides minimum length of continuous w-beam from the impact head for each proprietary Test Level 3 product. All radius, kinks, and transition sections must occur outside of the continuous w-beam section. SCDOT Standard Drawing 805-710-00 shows the required installation for systems with a 50' w-beam requirement. Where the design requires immediate transition from w-beam to thrie-beam at the end of the Type-T, confirm that adequate space exists in advance of the impact head before selecting a system that requires any length greater than 50'. The pay length for the TL3 Type T end terminal is shown in Special Provision Drawing 805-710-SP. No additional measurement or payment will be made for additional w-beam required by the selection of a proprietary product. Where sites do not accommodate longer end treatments, use a system with a 50' continuous w-beam section. When design includes a tangent installation of standard w-beam rail behind the 50' section, the designed rail will be measured and paid at 50' from the impact head as shown in the plan quantities.

For products with a 62'-6" requirement, see drawing 805-710-SP in Attachment B for additional guidance.

### **(66) SECTION 806: REPAIR EXISTING CONTROL OF ACCESS FENCE:**

Repair, replace or reset any damaged control of access fencing or fence components within the project limits, as directed by the RCE. Remove and dispose of existing fences, trees, brush, stumps,

## EXHIBIT 5 – SPECIAL PROVISIONS AND CONTRACT REQUIREMENTS

logs, weeds, or other debris that interfere with the construction of the fence. CONTRACTOR's bid shall include 1000 linear feet of Repair of Existing Control of Access Fence. Should the actual length of fence rehabilitation vary from this estimated value by more than 25%, a change order will be generated by the RCE to adjust the contract value based on the actual rehabilitated length of fence as measured by SCDOT inspectors, utilizing a unit price of **\$15.00/LF**, regardless of fence type. Ensure all waste materials and debris generated during this work is disposed of promptly and at appropriate waste facilities.

### **(67) SECTION 815: EROSION CONTROL MEASURES:**

In addition to the erosion control measures specified in the Plans, Standard Specifications, Supplemental Technical Specifications and the Special Provisions, the CONTRACTOR is advised that all land disturbing activities (clearing and grubbing, excavation, borrow and fill) are subject to the requirements set forth in the following permits and regulations:

- A. South Carolina Code of Regulations 63-380, Standard Plan for Erosion, Sediment, and Stormwater Runoff Control.
- B. Erosion and Sediment Reduction Act of 1983 (Title 48, Chapter 18 of the South Carolina Code of Laws of 1983, as amended). Section 70 of this code authorized the South Carolina Department of Health and Environmental Control (SCDHEC) to administer this regulation with respect to lands under the jurisdiction of the South Carolina Department of Transportation.
- C. National Pollutant Discharge Elimination System (NPDES) General Permit Number SCR160000, effective January 1, 2013: The Environmental Protection Agency, in accordance with the Federal Clean Water Act, has granted to the South Carolina Department of Health and Environmental Control (SCDHEC) the authority to administer the Federal NPDES permit program in the State of South Carolina.

In accordance with the NPDES General Permit, the Contractor must sign a Contractor Certification. The Contractor shall refer to Attachment B for the certification form. By signing this form, the Contractor acknowledges that upon award and execution of the Contract, he/she accepts/understands the terms and conditions of the *Storm Water Pollution Prevention Plan (SWPPP)* as required by the NPDES General Permit and may be legally accountable to SCDHEC for compliance with the terms and conditions of the *SWPPP*. In addition, the Contractor certifies that the NPDES certification statement status is made part of all its subcontracts.

The Contractor will complete and forward an updated SCDOT approved *Notice of Intent (NOI)* to the SCDOT Construction office to submit to SCDHEC. If the Coastal Zone Consistency (CZC) permit has not been approved it shall be forwarded by the Contractor to SCDOT to submit to SCDHEC as part of *NOI* package. If SCDHEC does not send a letter within 10 business days of receipt of the *NOI*, authorizing coverage, denying coverage, or advising that a review of the *CECP* will take place, coverage will be automatically granted.

Prepare and submit a *Contractor's Erosion Control Plan (CECP)* to the RCE before the pre-construction conference. Ensure that the plan meets the requirements of the NPDES General Permit. The plan will be reviewed and approved by the Department before commencing any land disturbing activities.

At the pre-construction conference, with contactors performing land-disturbing activities present, the *CECP* will be explained and discussed so that the Contractor is made aware of their responsibilities in the *CECP*.

Once approved, fully implement the *CECP*. Coordinate the prompt installation of erosion control devices with construction activities to maintain compliance with the above regulations and NPDES General Permit.

Conduct an Erosion and Sediment Control Inspection by an appointed Certified Erosion Prevention and Sediment Control Inspector (CEPSCI) from the Contractor and the Department at least every 7-calendar days. Both parties will acknowledge participation in the inspection by signing the inspection

## EXHIBIT 5 – SPECIAL PROVISIONS AND CONTRACT REQUIREMENTS

report and include their inspector's CEPSCI number on the report. Correct deficiencies noted during these inspections within the assigned priority period. If deficiencies are not corrected within this timeframe, the RCE will stop all work (except erosion and sediment control measures) until the deficiencies are corrected.

Give special attention to critical areas within the project limits (i.e., running streams, water bodies, wetlands, etc.). In these areas, the RCE may direct the Contractor to undertake immediate corrective action, but in no case allow these deficiencies to remain unresolved more than 7 days or 48 hours in accordance with their assigned priority after being identified during the Erosion and Sediment Control Inspection.

Closely follow the grading operations with the seeding operations. Shape and prepare the slopes for seeding as the grading progresses. Unless the RCE grants prior written approval, limit the amount of surface area exposed by land disturbing activities to 750,000 square feet. Commence seeding operations within 7 days following completion of construction activities within an area.

Initiate stabilization measures within 7 days for an area where construction activities will be temporarily or permanently ceased for 14 days or longer.

Coordinate the installation of all other permanent erosion control items with the grading and seeding operations. These items include, but are not limited to, asphalt gutter and riprap. Construct gutter work before or promptly after the seeding is performed. Place riprap at the ends of pipe immediately after the pipe is laid and promptly install riprap ditch checks after ditch work has been performed.

Within existing right of way, clean and repair existing concrete paved ditches that will be retained. Within existing right of way, clean and repair existing asphalt paved ditches that are to be retained and overlay with 200 lbs/sy HMA Surface Course Type C or D. Stabilize new ditches in accordance with the *SCDOT Requirements for Hydraulic Design Studies* (May 26, 2009), the *SCDOT Water Quality Design Manual* (December 2014) and as needed for erosion control utilizing SCDHEC Best Management Practices (BMP's).

Failure to adequately comply with the provisions as detailed above or any other required erosion control measures will result in stoppage of all contract operations (except erosion and sediment control measures) until corrective action has been taken. Additional sanctions may be invoked by the SCDHEC in accordance with their authority.

Keep the following documents at the RCE's office from the start of construction until the site is finally stabilized:

- A. Copy of the *CECP*,
- B. Copies of Contractor Certification statements,
- C. Copy of the permit,
- D. Letter from DHEC authorizing permit coverage if provided by SCDHEC, and
- E. A marked-up set of site plans.

When uniform perennial vegetation achieves a cover density of 70%, submit a *Notice of Termination (NOT)* to SCDHEC to terminate coverage. Include a signed statement with the *NOT* certifying that all work on the site has been completed in accordance with the *SWPPP* and the NPDES General Permit for all sites one acre or greater.

Fines assessed on the Department by SCDHEC as the result of the CONTRACTOR's non-compliance or violation of said permit provisions will be paid by the Department and will subsequently be deducted from any monies due or that may become due to the CONTRACTOR. In case no monies are due or available, the fines incurred will be charged against the CONTRACTOR's Surety.

**(68) SECTION 815: ANIONIC POLYACRYLAMIDE FOR EROSION CONTROL:**

**A. DESCRIPTION**

This work consists of applying a product containing anionic polyacrylamide to disturbed land areas as a means of controlling erosion. The work also consists of the use of solid form anionic polyacrylamide as a means of sediment control.

**B. MATERIALS**

The product to be used is to be specific to the area to be treated. Product selection and application rate is to be determined by a testing laboratory acceptable to SCDOT. Preliminary site-specific assessment (soil and water testing) by a qualified manufacturer must be conducted to select media, additives, application rate, application method and maintenance procedure tailored to site-specific soil characteristics, topography, hydrology, and the type of erosion targeted. A copy of the test results is to be provided to the Engineer.

Anionic polyacrylamide, in pure form, shall have less than or equal to 0.05% acrylamide monomer by weight, as established by the Food and Drug Administration and the Environmental Protection Agency. The maximum application rate of polyacrylamide, in pure form, shall not exceed 200 pounds/acre/year, or 10 pounds/acre per single application event.

The polyacrylamide shall have a charge density of 10% to 55%, by weight. The polyacrylamide shall have a molecular weight of 6 to 24 Mg/mole.

The polyacrylamide and polyacrylamide mixtures shall be noncombustible.

**Cationic forms of polyacrylamide are not allowed for use due to their high level of toxicity.**

**Polyacrylamide shall be non-toxic. A toxicity report is required to be submitted to the Engineer.**

**C. CONSTRUCTION REQUIREMENTS**

Liquid and powder forms of polyacrylamide are to be either applied directly to the exposed soil surface or applied as a tackifier with temporary seeding to prevent detachment of soil particles during the establishment of vegetation.

In the solid form, the polymer is to be placed directly into the storm water runoff to enhance eroded particle settlement in a trapping device.

Polyacrylamide shall be mixed and/or applied in accordance with all Occupational Safety and Health Administration (OSHA) Material Safety Data Sheet (MSDS) requirements and the manufacturer's recommendations for the specified use conforming to all federal, state and local laws, rules and regulations. The Contractor is responsible for obtaining all required permits.

Emulsion batches shall be mixed following recommendations of a testing laboratory that determines the proper product and rate to meet site requirements.

Additives such as fertilizers, solubility promoters, or inhibitors, etc. to polyacrylamide shall be nontoxic.

Care is to be taken when using polyacrylamide adjacent to natural water bodies.

**D. METHOD OF MEASUREMENT**

The application of polyacrylamide for erosion control will be measured by the surface area treated at the recommended rate of application. Quantities are to be computed to the nearest MSY (Thousand Square Yards). Solid form anionic polyacrylamide is to be measured by weight

**EXHIBIT 5 – SPECIAL PROVISIONS AND CONTRACT REQUIREMENTS**

in pounds, in place and accepted. The Contractor is required to provide, to the Engineer, invoices for all polyacrylamide products used on the project.

**E. BASIS OF PAYMENT**

The accepted quantity of “Anionic Polyacrylamide For Erosion Control” will be paid at the contract unit price, which price and payment shall be full compensation for all materials, labor, tools equipment, and incidentals necessary to complete the work herein described in a workmanlike and acceptable manner. Solid form anionic polyacrylamide is to be paid for by the pound. Bid Item Numbers and Descriptions are as follows:

<b>Bid Item Number</b>	<b>Description</b>	<b>Unit</b>
8152020	ANIONIC POLYACRYLAMIDE FOR EROSION CONTROL	MSY
8152025	SOLID FORM ANIONIC POLYACRYLAMIDE	LBS